

Industrial Automation Control Valves

*XM Series, Viking Xtreme Series,
Directair 2 Series, Directair 4 Series,
42 Series, DX ISOMAX Series*

Catalog 0668/USA



Parker Hannifin Corporation

A global, Fortune 300 company with sales of \$8 billion and over 400,000 customers in 46 countries, Parker Hannifin is the world's leading supplier of motion control components and system solutions serving the industrial, mobile, and aerospace markets.

Excellence is imprinted on our corporate DNA. We are the only manufacturer offering customers a choice of hydraulic, pneumatic, electromechanical, or computer motion control.

Total Systems Solutions

Parker's team of highly qualified applications engineers, product development engineers, and system specialists can turn pneumatic, structural extrusion, and electromechanical products into an integrated system solution. And our Selectable Levels of Integration™ program provides the components, subsystems, and controlled motion systems for the level of integration you choose.



Parker consistently raises the bar for its manufacturing plants and distributors, measuring its delivery to customer request date.

1st in Delivery, Field Sales and Distribution

Parker boasts the industry's largest global distribution network, with more than 8,600 distributors worldwide. With factories located strategically on five continents, we can maintain matchless on-time delivery rates.

Expect industry's fastest response and delivery by customer request date when you contact Parker or one of its distributors. Plus, Parker's army of pneumatic engineers works hand-in-hand with you and your local distributors during the design process to ensure the best products, services, and application performance.

Parker Pneumatic Distribution offers the next level in premier customer service. Each location has significant on-hand inventory to keep your down time to a minimum. And many distributors have in-house design capability to support your system and subsystem requirements.



Parker world headquarters in Cleveland



Training

Parker's best-in-class technology training includes hands-on classes, Web-based training, and comprehensive texts for employees, distributors, and customers. Parker also provides

computer based training, PowerPoint presentations, exams, drafting and simulation software, and trainer stands.

Five-Year Warranty

Our standard 18-month warranty on pneumatic products is extended to 60 months when used with a properly installed and maintained Parker air preparation system.

www.parker.com/pneumatics

Industry's most comprehensive Web site is your single source for:

- Product information
- Downloadable catalogs
- 3D design files
- Training materials
- Product configuration software
- RFQ capabilities



24/7 Emergency Breakdown Referrals

The Parker product information center is available any time of the day or night at 1-800-C-Parker. Our operators will connect you with on-call representatives who will identify replacement parts or services for all motion technologies. Talk to a real person!





**Global
Pneumatics**

This icon can be found next to products that are widely supported by Parker Pneumatics' worldwide manufacturing and sales network. When you see this icon, you can be confident that this product is manufactured and / or stocked* worldwide for rapid delivery. In addition to local manufacturing or inventory, our sales network has been specifically trained on these products to provide our customers with the best possible service.

Products not showing this icon are still sold and distributed worldwide. However, The Global Pneumatics icon represents products that customers can expect the best level of support.

If you are a multi-national company, seek global sourcing or ship globally, depend on Parker Pneumatic for **PREMIER CUSTOMER SERVICE**.

* Stocking levels vary by country

WARNING

FAILURE OR IMPROPER SELECTION OR IMPROPER USE OF THE PRODUCTS AND/OR SYSTEMS DESCRIBED HEREIN OR RELATED ITEMS CAN CAUSE DEATH, PERSONAL INJURY AND PROPERTY DAMAGE.

This document and other information from Parker Hannifin Corporation, its subsidiaries and authorized distributors provide product and/or system options for further investigation by users having technical expertise. It is important that you analyze all aspects of your application including consequences of any failure, and review the information concerning the product or system in the current product catalog. Due to the variety of operating conditions and applications for these products or systems, the user, through its own analysis and testing, is solely responsible for making the final selection of the products and systems and assuring that all performance, safety and warning requirements of the application are met.

The products described herein, including without limitation, product features, specifications, designs, availability and pricing, are subject to change by Parker Hannifin Corporation and its subsidiaries at any time without notice.

Offer of Sale

The items described in this document are hereby offered for sale by Parker Hannifin Corporation, its subsidiaries or its authorized distributors. This offer and its acceptance are governed by the provisions stated on the separate page of this document entitled "Offer of Sale".

© Copyright 2007, Parker Hannifin Corporation. All Rights Reserved.



Technical Information

Saving Money and Space by Sizing Your Valves Properly

This catalog gives you a flow rating (Cv) for each valve in the Parker Hannifin line. You can “plug” your requirements into the following simple formula, and determine the Cv needed to do the job. By not oversizing, you’ll save space and money, and you’ll ensure the valve you select will do the job.

Converting the Job Requirements Into Cv (Capacity Co-efficient).

$$Cv = \frac{\text{Cylinder Area (Sq. In.)} \times \text{Cylinder Stroke (In.)} \times \text{Compression Factor (Table 2)} \times \text{“A” (Table 2)}}{\text{Stroke Time (sec.)} \times 28.8}$$

Let’s work through an example:

We want to extend a 3¼" bore cylinder which has a 12" stroke in one second, and we have a supply pressure of 80 PSI to do the work. Here’s what we know:

- Cylinder area for a 3¼" bore, from Table 1..... 8.30 sq. in.
- Cylinder stroke..... 12 in.
- Stroke time required in seconds..... 1 sec.
- Compression factor at 80 PSI, from Table 2 6.4
- “A” constant for 80 PSI, from Table 2..... 0.048

Substituting in the formula, we have:

$$Cv = \frac{8.30 \times 12 \times 6.4 \times .048}{1 \times 28.8} = 1.06$$

Any valve, therefore, which has a Cv of *at least* 1.06, will extend our cylinder the specified distance in the required time.

Choosing the Valve “Series”

Your next step is to choose a basic valve design to do the job. For a quick guide to valve designs, see Table 3.

Having selected the basic valve design, consult the Capacity Co-efficient (Cv) tables which describe the individual valve capacities.

Selecting the Valve Model, Options and Accessories

Having determined Cv, series, port size, flow-path configuration (pre-determined by circuit design), and actuation method, you’re ready to choose the *exact* valve model number.

Read the pertinent catalog pages; note the exact model numbers, options and accessories you want. Then phone or write your Parker Hannifin air valve distributor. They will give you prompt, accurate service.

Note: Need circuit design help? Contact your local Parker Hannifin distributor. They are backed up by our regional Sales Engineers and offices. Between them, you’ll find answers to all of your questions.

Table 1
Effective Square-Inch Areas for Standard-Bore-Size Cylinders

Bore Size	Cylinder Area (Sq. In.)	Bore Size	Cylinder Area (Sq. In.)
¾"	0.44	4"	12.57
1"	0.79	4½"	15.90
1⅛"	0.99	5"	19.64
1¼"	1.23	6"	28.27
1½"	1.77	7"	38.48
1¾"	2.41	8"	50.27
2"	3.14	10"	78.54
2½"	4.91	12"	113.10
3¼"	8.30	14"	153.94
3⅝"	10.32		

Table 2
Compression Factors and “A” Constants

Inlet Pressure (PSIG)	Compression Factor	“A” Constants for Various Pressure Drop*		
		2 PSI ΔP	5 PSI ΔP	10 PSI ΔP
10	1.6	0.155	0.102	
20	2.3	0.129	0.083	0.066
30	3.0	0.113	0.072	0.055
40	3.7	0.097	0.064	0.048
50	4.4	0.091	0.059	0.043
60	5.1	0.084	0.054	0.040
70	5.7	0.079	0.050	0.037
80	6.4	0.075	0.048	0.035
90	7.1	0.071	0.045	0.033
100	7.8	0.068	0.043	0.031
110	8.5	0.065	0.041	0.030
120	9.2	0.062	0.039	0.029
130	9.9	0.060	0.038	0.028
140	10.6	0.058	0.037	0.027
150	11.2	0.056	0.036	0.026
160	11.9	0.055	0.035	0.026
170	12.6	0.054	0.034	0.025
180	13.3	0.052	0.033	0.024
190	14.0	0.051	0.032	0.024
200	14.7	0.050	0.031	0.023

Note: Use “A” constant at 5 PSI ΔP for most applications. On very critical applications, use “A” at 2 PSI ΔP. You will find in many cases, a 10 PSI ΔP is not detrimental, and can save money and mounting space.

* Tabulated values are the solution of $\frac{1}{22.48} \sqrt{\frac{GT}{(P_1 - P_2) P_2}}$ where T is for 68°F and G = 1 for Air.

Table 3
Characteristics of the Major Valve Designs

A. Poppet 3-Way and 4-Way	<ol style="list-style-type: none"> High flow capacities Minimum lubrication requirements Fast response Self-cleaning poppet seats Pressures of 15 to 150 PSIG (modifications for vacuum to 250 PSIG)
B. Spool Valves (WCS) 3-Way and 4-Way	<ol style="list-style-type: none"> Low friction Lower operating pressures Fast response Less wear Long Cycle Life - Under pressure, radial expansion of the seal occurs to maintain sealing contact with the valve bore Non-Lube Service - No lubrication required for continuous valve shifting Bi-Directional Spool Seals - Common spool used for any pressure, including vacuum
C. Packed Bore 4-Way	<ol style="list-style-type: none"> Wide range of flow capacities Wide range of flow-path configurations Pilot-operated models available Pressures of vacuum to 150 PSIG
D. Rotary Or Reciprocating Disc 4-Way, manually operated	<ol style="list-style-type: none"> Inexpensive Versatility in manual actuation

Cv-Capacity Co-efficients—(sometimes called Flow Factors). Each flow path through the valve has its own Cv value. All Cv ratings for each valve cataloged on this page are listed on the front side of this sheet.

Q = Flow in Standard Cubic Feet per minute (14.7 PSIA at 60°F)

$$Cv = \frac{Q}{22.48} \sqrt{\frac{GT}{(P_1 - P_2) P_2}}$$

P₁ = Inlet Absolute Pressure (gauge pressure + 14.7)
 P₂ = Outlet Absolute Pressure (gauge pressure + 14.7)
 Note: P₂ must be greater than 0.53 x P₁
 G = Specific Gravity of flowing medium (Air, G = 1)
 T = Absolute Temperature of Air (460 + °F)

Cv = Q x “A” (Table 2)



“XM” Series	A XM Series
Viking Xtreme Series www.parker.com/pneu/viking	B Viking Xtreme Series
Directair 2 Series, Manual/Mechanical www.parker.com/pneu/directair	C Directair 2 Series
Directair 4 Series, Manual/Mechanical www.parker.com/pneu/directair	D Directair 4 Series
“42” Lever / Pedal Series www.parker.com/pneu/42ser	E 42 Lever / Pedal Series
“DX” ISOMAX Series	F DX ISOMAX Series
Safety Guide, Offer of Sale	G Safety Guide, Offer of Sale

Notes



"XM" Series

Air Control Valves

Direct Acting, 1/8" Port

3-Way & 4-Way: .14 Cv

A

Section A

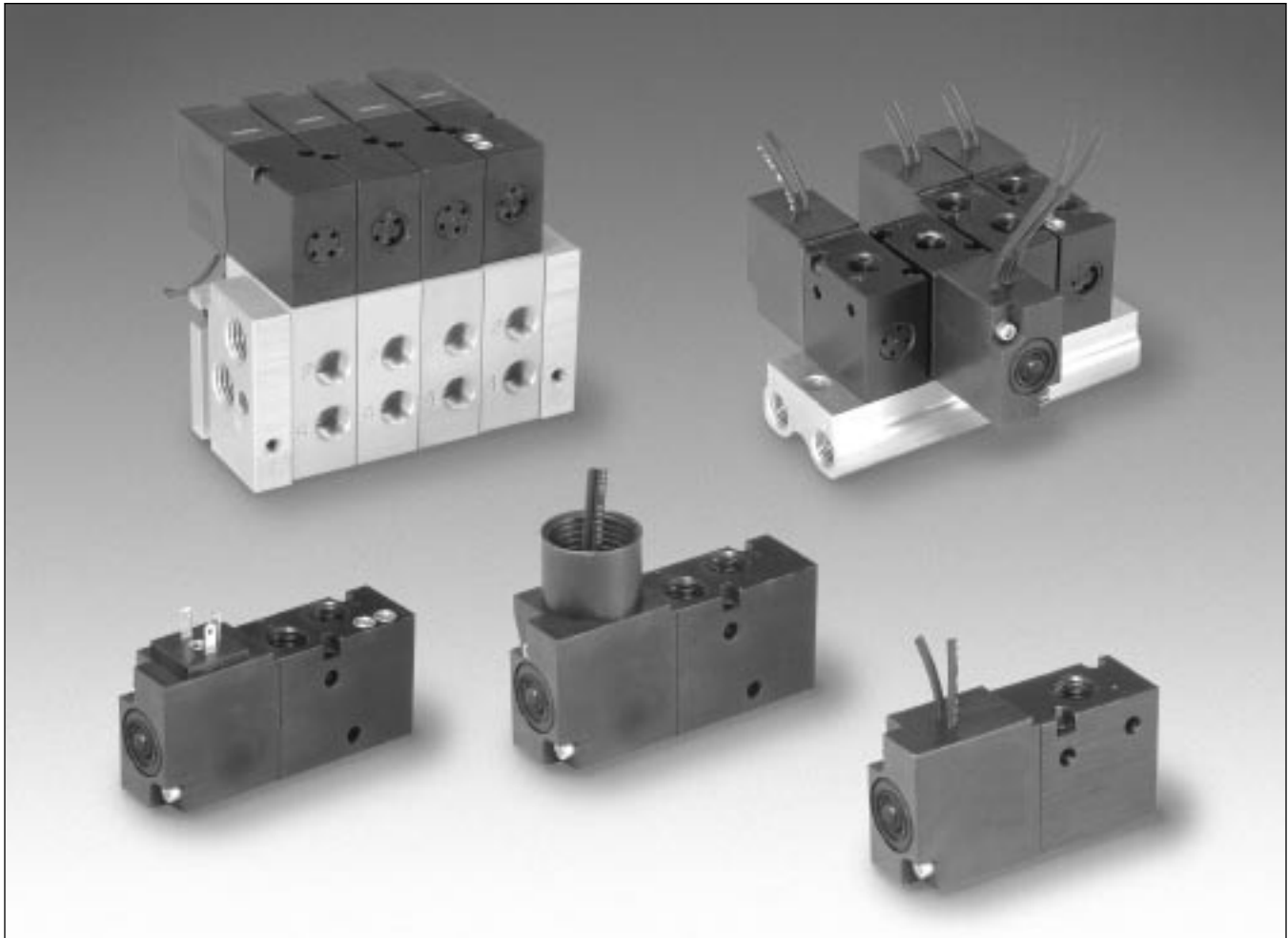

Basic Valve Functions	A2	Kits & Accessories	A9
XM Series Basic Features.....	A3	Dimensions.....	A10-A13
Common Part Numbers.....	A4		
Model Number Index.....	A5		
IEM Bar Manifolds & Subbase Manifolds.....	A6		
Manifold Ordering Information.....	A7		
Technical Information.....	A8		

BOLD ITEMS ARE MOST POPULAR.

Standard text part numbers may have longer lead times.



A

3-Way, 2-Position, Normally Closed

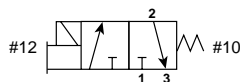

De-energized position – Solenoid #12 de-energized. Pressure at inlet port 1 blocked, outlet port 2 connected to exhaust port 3.

Energized position – Solenoid #12 energized. Pressure at inlet port 1 is connected to outlet port 2, exhaust port 3 is blocked.

3-Way, 2-Position, Normally Open

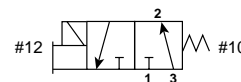

De-energized position – Solenoid #12 de-energized. Pressure at inlet port 3 connected to outlet port 2, exhaust port 1 is blocked.

Energized position – Solenoid #12 energized. Pressure at inlet port 3 blocked, outlet port 2 connected to exhaust port 1.

3-Way, 2-Position, Diverter

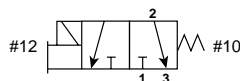

De-energized position – Solenoid #12 de-energized. Pressure at inlet port 2 connected to outlet port 3. Port 1 is blocked.

Energized position – Solenoid #12 energized. Pressure at inlet port 2 is connected to outlet port 1. Port 3 is blocked.

3-Way, 2-Position, Selector

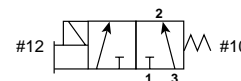

De-energized position – Solenoid #12 de-energized. Pressure at inlet port 1 is blocked. Pressure at inlet port 3 is connected to outlet port 2.

Energized position – Solenoid #12 energized. Pressure at inlet port 1 is connected to outlet port 2. Pressure at port 3 is blocked.

2-Way, 2-Position, Normally Closed

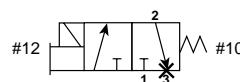

De-energized position – Solenoid #12 de-energized. Pressure at inlet port 1 blocked, port 2 is connected to port 3, which is plugged.

Energized position – Solenoid #12 energized. Pressure at inlet port 1 is connected to outlet port 2. Port 3 is blocked.

* Plug port 3.

2-Way, 2-Position, Normally Open

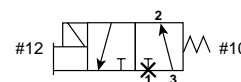

De-energized position – Solenoid #12 de-energized. Pressure at inlet port 3 is connected to outlet port 2. Port 1 is blocked.

Energized position – Solenoid #12 energized. Pressure at inlet port 3 is blocked. Port 2 is connected to port 1, which is plugged.

* Plug port 1.

4-Way, 2-Position

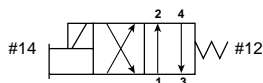

De-energized position – Solenoid #14 de-energized. Pressure at inlet port 1 connected outlet port 2. Outlet port 4 connected to exhaust port 3.

Energized position – Solenoid #14 energized. Pressure at inlet port 1 is connected to outlet port 4. Outlet port 2 connected to exhaust port 3.

4-Way, 2-Position with Flow Controls

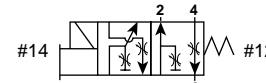

De-energized position – Solenoid #14 de-energized. Pressure at inlet port 1 connected outlet port 2. Outlet port 4 connected to exhaust port 3.

Energized position – Solenoid #14 energized. Pressure at inlet port 1 is connected to outlet port 4. Outlet port 2 connected to exhaust port 3.

Flow Controls meter exhaust from ports 2 and 4 separately into port 3.

Flow Characteristics

- 3-Way: .15 Cv
- 4-Way: .15 Cv

3-Way Operating Pressure

- 0 to 125 PSIG
- 0 to -14.7 PSIG

4-Way Operating Pressure

- -14.7 to 125 PSIG

Ports

- 1/8" NPT

Mounting

- Inline
- IEM Bar Manifold
- Subbase Valve Manifold

Solenoids

- Continuous Duty Rated
- 24" Grommet
- 15mm 3-Pin (9.4 mm Pin Spacing)
- 1/2" Conduit
- 12VDC to 240VAC

Balanced Poppet

- 3-Way N.O. & N.C.
- Diverter
- Selector
- Vacuum Option

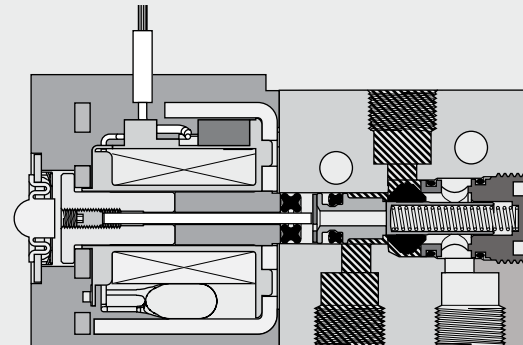

3-Way Inline Valve
Shown Energized

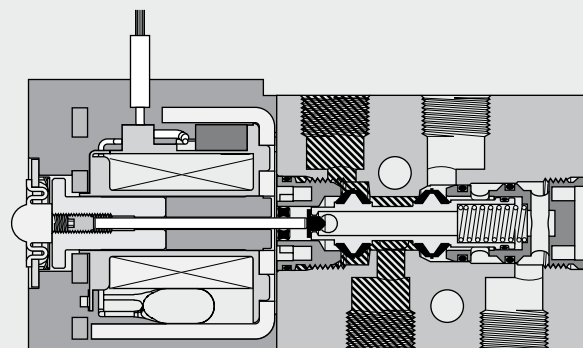

4-Way Inline Valve
Shown De-Energized

 Pressure  Exhaust

A

A

Inline Valves

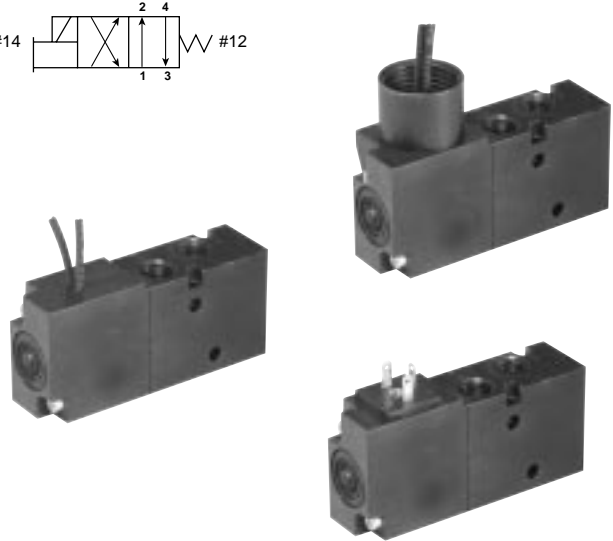
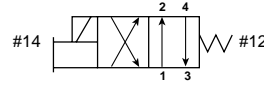
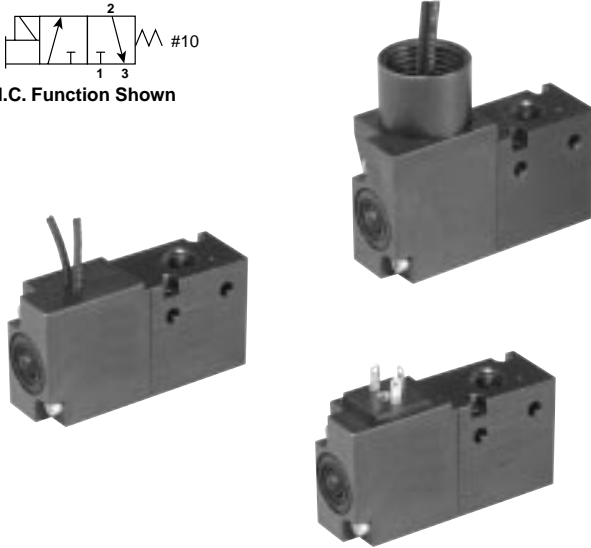
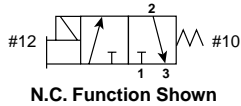

3-Way

24" Grommet	3-Pin 15mm DIN 9.4mm	1/2" Conduit / 24" Leads	Voltage
XM30NBG49A	XM30NB549A	XM30NBH49A	24VDC
XM30NBG53A	XM30NB553A	XM30NBH53A	120VAC

Note: All units with non-locking flush override.
 Can be used as N.O / N.C. / Diverter / Selector function.

4-Way

24" Grommet	3-Pin 15mm DIN 9.4mm	1/2" Conduit / 24" Leads	Voltage
XM40NBG49A	XM40NB549A	XM40NBH49A	24VDC
XM40NBG53A	XM40NB553A	XM40NBH53A	120VAC

Note: All units with non-locking flush override.

Subbase Mount

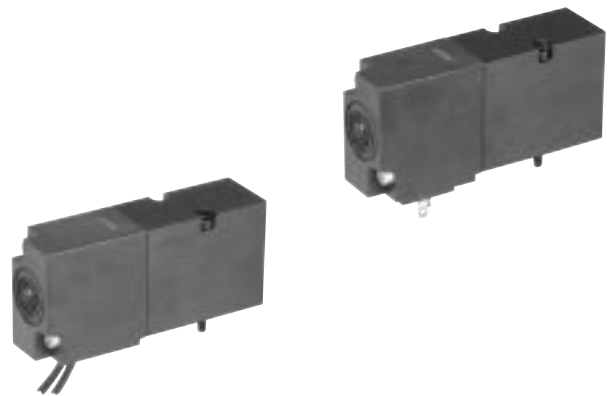
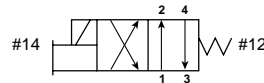
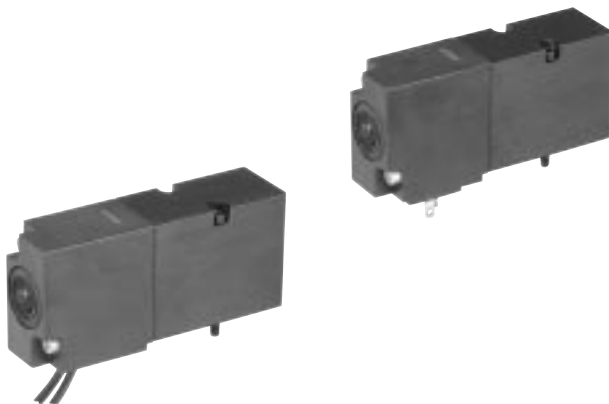
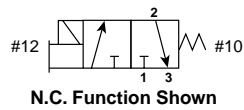

3-Way

24" Grommet	3-Pin 15mm DIN 9.4mm	Voltage
XM3VNBG49A	XM3VNB549A	24VDC
XM3VNBG53A	XM3VNB553A	120VAC

Note: All units with non-locking flush override.
 Can be used as N.O / N.C. / Diverter / Selector function.

4-Way

24" Grommet	3-Pin 15mm DIN 9.4mm	Voltage
XM4VNBG49A	XM4VNB549A	24VDC
XM4VNBG53A	XM4VNB553A	120VAC

Note: All units with non-locking flush override.

BOLD OPTIONS ARE MOST POPULAR.



XM 4 0 N B G49 — A

Operator / Function	
3-Way, Direct Operated, Single Solenoid, Spring Return	3
4-Way, Direct Operated, Single Solenoid, Spring Return	4

Engineering Level	
A	Current

Port Size / Thread Type	
1/8" NPT Inline	0*
Subbase Valve Less Base	V

* Available on IEM manifolds.

Options	
Blank	None
FO*	Flow Control

* 4-Way Valves Only.

Pilot Source / Exhaust	
Direct Operated / Standard Pressure	N*
Direct Operated / Vacuum Service	V**

* 3-Way Valve Positive Pressure,
 4-Way Valve Vacuum or Positive Pressure
 ** 3-Way Valve Vacuum Pressure.

Overrides	
Flush - Non-Locking	B

		Enclosures / Lead Length		
		Voltage		
		AC		DC
		60Hz	50Hz	
542	15mm 3-Pin DIN 9.4mm	24	22	
545*	15mm 3-Pin DIN 9.4mm			12
549*	15mm 3-Pin DIN 9.4mm			24
553	15mm 3-Pin DIN 9.4mm	120	110	
G42	Grommet / Flying Leads 24"	24	22	
G45*	Grommet / Flying Leads 24"			12
G49*	Grommet / Flying Leads 24"			24
G53	Grommet / Flying Leads 24"	120	110	
G57	Grommet / Flying Leads 24"	240	220	
H42†	1/2" Conduit / Flying Leads 24"	24	22	
H45*†	1/2" Conduit / Flying Leads 24"			12
H49*†	1/2" Conduit / Flying Leads 24"			24
H53†	1/2" Conduit / Flying Leads 24"	120	110	

* Mobile Voltage Rated.
 † Inline Version Only.

Notes:
Inline Valves
 Conduit Inline valves cannot be mounted to IEM or Subbase Manifolds.



A

IEM Bar Manifold Assembly

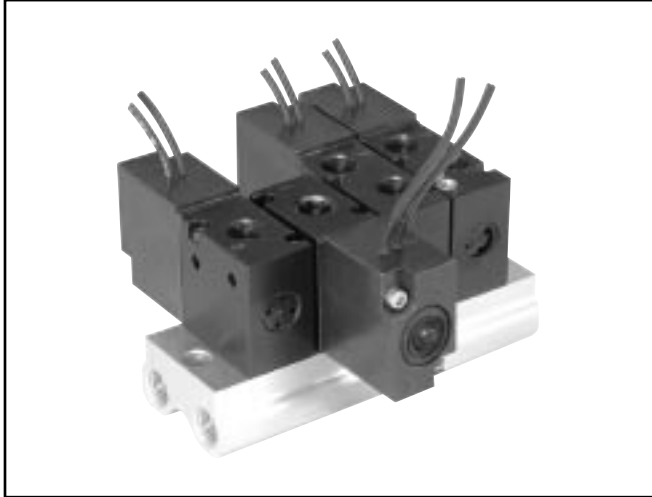

IEM Bar Manifold

Allows for mounting of 3-Way and 4-Way Inline valves on the same manifold. 3-Way Valves can be mounted on the same manifold to provide a Normally Closed or Normally Open function by rotating the valves 180°. 4-Way valves can be mounted with or without Flow Controls.

IEM Bar Manifold Assemblies consist of valves and an IEM Manifold. Valves and IEM Manifold can be ordered separately.

Subbase Manifold Assembly

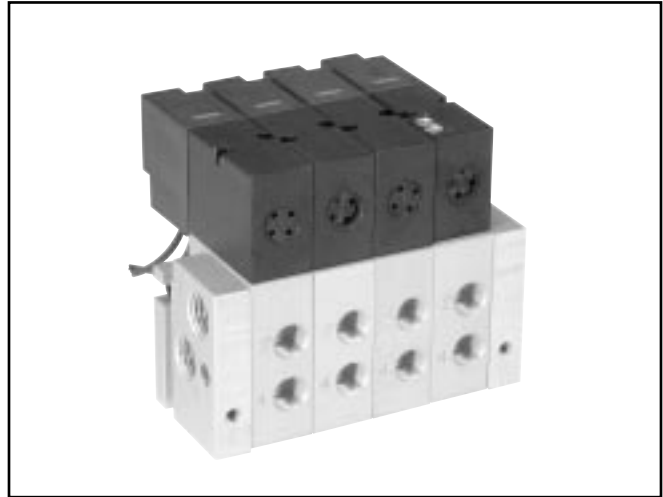

Subbase Manifold

Allows for mounting of 3-Way and 4-Way Subbase Valves can be mounted on the same manifold. 3-Way Valves can be mounted on the same manifold to provide a Normally Closed or Normally Open function through the use of port isolation kits. 4-Way valves can be mounted with or without Flow Controls.

Subbase Manifold Assemblies consist of Valves, End Plate Kit and Manifold Subbase Kits. Valves, End Plate Kit and Manifold Subbase Kits can be ordered separately.



IEM Bar Manifold (NPT) **PSMXNXN##NP**
– stations 02 to 12

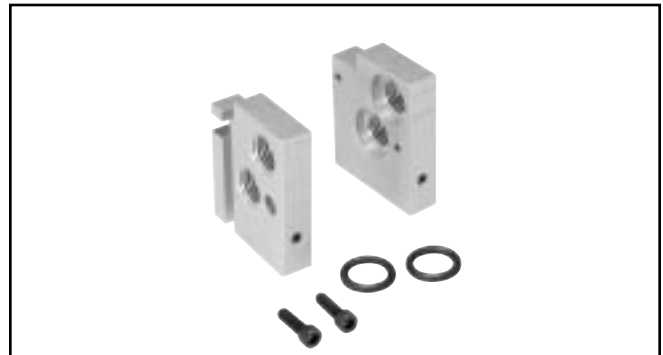

End Plate Kit (NPT) **PSXM31010P**



Manifold Subbase Kit (NPT) **PSXM530CP**

How to Order Manifold Assemblies

BOLD OPTIONS ARE MOST POPULAR.

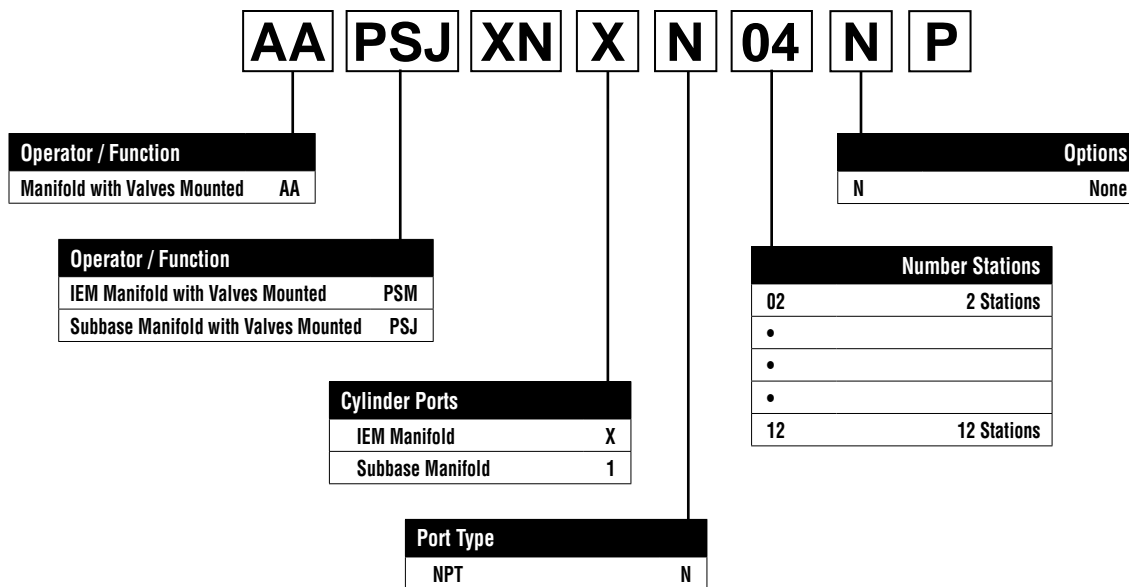

IEM Bar Manifold Assembly

First line item describes IEM Assembly. Subsequent line items listed identify each station in the Manifold starting with Station Number 1.

Subbase Manifold Assembly

First line item describes Subbase Assembly. Subsequent line items listed identify each station in the Manifold starting with Station Number 1.

Manifold Assembly Ordering Example

Item	Qty	Part Number
001	1	AAPSMXNXN04NP
002	2	XM30NBG49A - Station 1, 2 - Normally Closed
003	1	XM40NBG49A - Station 3
004	1	XM40NBG49F0A - Station 4

Notes: When ordering Add-A-Folds, list valves left to right when looking at the Port 1/3 side of the manifold. All 3-Way valves will be assembled as 3-Way N.C. valves.

Subbase Manifold Ordering Example

Item	Qty	Part Number
001	1	AAPSJXN1N04NP
002	2	XM3VNBG49A - Station 1, 2 - Normally Closed
003	1	XM4VNBG49A - Station 3
004	1	XM4VNBG49F0A - Station 4

Notes: When ordering Add-A-Folds, list valves left to right when looking at the Port 2/4 side of the manifold. All 3-Way valves will be assembled as 3-Way N.C. valves. Isolator Discs are required for N.O. functions

Component Ordering Example

Item	Qty	Part Number
001	1	PSMXNXN04NP (IEM Kit)
002	2	XM30NBG49A (Valve)
003	1	XM40NBG49A (Valve)
004	1	XM40NBG49F0A (Valve)

Component Ordering Example

Item	Qty	Part Number
001	1	PSXM31010P (End Plate Kit)
002	4	PSXM530CP (Subbase Kit)
003	2	XM3VNBG49A (Valve)
004	1	XM4VNBG49A (Valve)
005	1	XM4VNBG49F0A (Valve)



A

Inline Valve on IEM Bar Manifold Assembly

IEM Bar Manifold Assembly's are assembled by adding Inline Valves to an IEM Bar Manifold. O-rings are installed at each valve station in the counterbore on the top of the manifold. Valves are installed with 2 mounting screws. For 3-Way N.C. valve operation, line up the solenoid end of the Valve with Port 1 on the Manifold. For 3-Way N.O. operation, line up the solenoid end of the valve with Port 3 on the manifold. For 4-Way valve operation, line up the Solenoid end of the valve with Port 1 on the manifold. If manifolds are factory assembled, all 3-Way valves are N.C. To convert from N.C. to N.O. operation, remove valve from the base and place valve 180° from the original position with the solenoid end lined up with the 3-Port on the manifold.

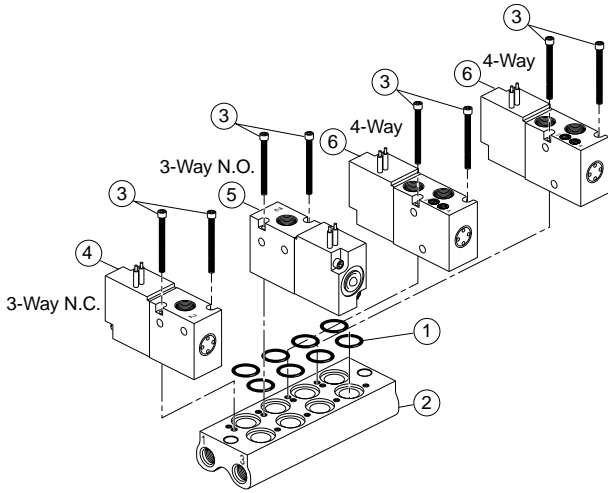

Subbase Valve and Manifold Assembly

Subbase Manifold Assembly's are assembled by adding tie rods and manifold bases to the end plate kit of the subbase end plate kit as shown below. Valves are added to each subbase per manifold design. 4-Way and 3-Way valves are mounted with Solenoids Coils facing away from subbase delivery ports 2 and 4. For 3-Way N.O. Functions, valves must be isolated from the other 3-Way N.C. and 4-Way valves on the manifold. This is achieved by placing port isolator discs in between the subbase of the first 3-Way N.O. Valve and the subbase of the last 3-Way N.C. or 4-Way valve in the Subbase Manifold. Inlet pressure is connected to Port 3 of the manifold for the 3-Way N.O. valves. Inlet pressure is connected to the Port 1 of the manifold for the 3-Way N.C. and 4-Way valves. Separate Inlet Pressure Ports and Exhaust Ports are required for N.O. and N.C. 3-way function valves.

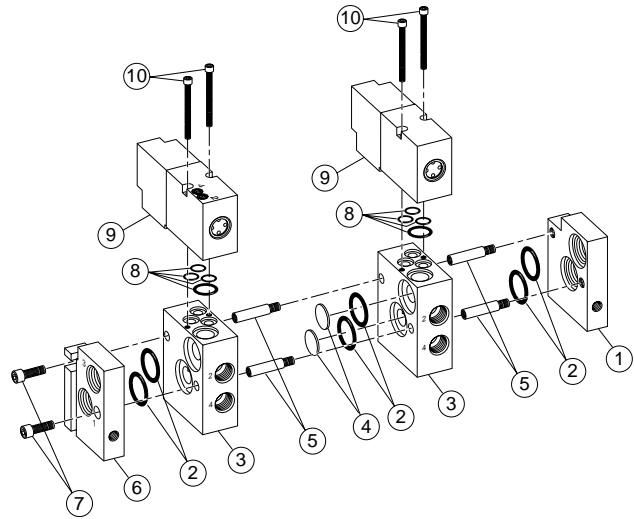

Performance Information

Code	Electrical				Holding Current (Amps)	Flow		Seals
	Voltage		Power Consumption (W / VA)	Cv Chart				
	AC	DC		3-Way		4-Way		
	60Hz	50Hz						
42	24	22	—	4.8VA	.200	.15	.15	Buna N
45*	—	—	12	4.5W	.375	.15	.15	
49*	—	—	24	4.5W	.188	.15	.15	
53	120	110	—	4.32VA	.036	.15	.15	
57	240	220	—	4.32VA	.018	.15	.15	
Note: Voltage Tolerance: +10 / -15%						Cv tested per ANSI / (NFPA) T3.21.3		

* Mobile Voltage, +25/-30%

Response Time

Code	Voltage	0 Cu. In. Test Chamber		12 Cu. In. Test Chamber	
		Fill	Exhaust	Fill	Exhaust
49	24VDC	.011	.007	.240	.384
53	120VAC	.011	.020	.240	.384

Average Fill Time (Seconds): With 100 PSIG supply, time required to fill from 0-90 PSIG and exhaust from 100 PSIG to 10 PSIG is measured from instant of energizing, or de-energizing solenoid. Times shown are average.

Tested per ANSI / (NFPA) T3.21.8.

Operating Pressure

Function / Pilot Source	Minimum	Maximum
3-Way, N	0 PSIG	125 PSIG
3-Way, V	Vacuum	25 PSIG
4-Way, N	Vacuum	125 PSIG

Temperature Rating

32°F to 125°F (0°C to 50°C)



Blanking Plate



Kit Number	
IEM Universal NPT	Subbase Blank
PSXM2194P	PSXM8310P

Subbase Kit includes: (3) Screws

IEM Valve / Manifold O-ring Kit



Part Number	Description
PSXM2186P	IEM Valve / Manifold O-ring Kit

Mounting Bracket - Inline Valve



Part Number	Description
PSXM8288P	Mounting Bracket

Subbase Valve / Manifold Bolt Kit

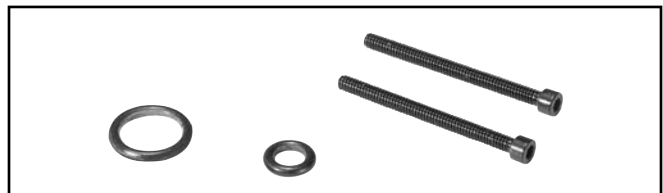

Part Number	Description
PSXM8100P	Subbase Valve / Manifold Bolt Kit

Isolator Plugs - Subbase Manifold



Part Number	Description
PSXM40900P	Isolation Plugs

Plug-in Electrical Connectors - 9.4mm



Indication	Voltage	Unwired Plug	Plug with 6' Lead
None	N/A	PESC10	PESC12
LED & Suppression	12/24V	PESC2020B	PESC2220B
	120VAC	PESC2001F	PESC2201F

A

A

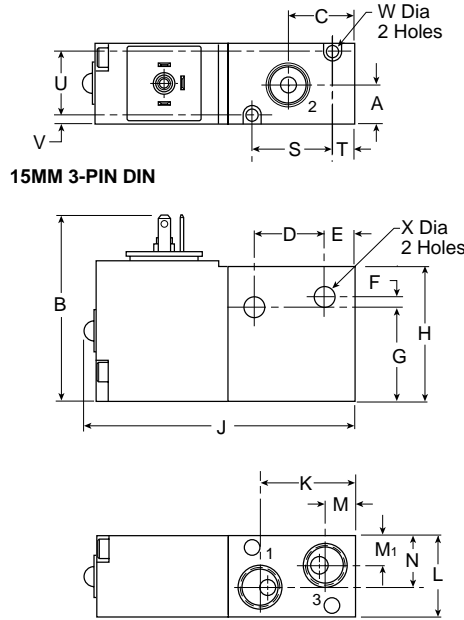
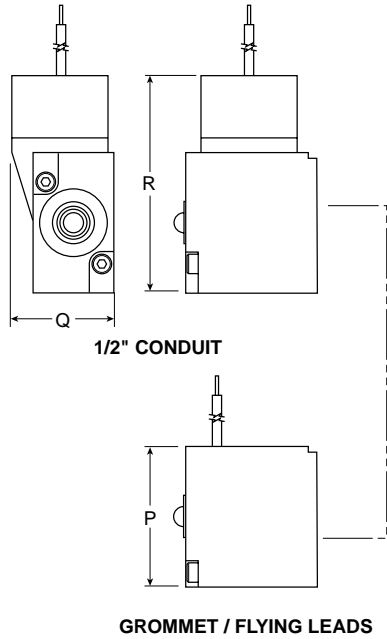

XM 3-Way Inline

A .38 (10)	B 1.69 (43)	C .62 (16)	D .66 (17)	E .28 (7.0)
F .10 (2.5)	G .87 (22)	H 1.25 (32)	J 2.50 (64)	K .87 (22)
L .75 (19)	M .28 (7.0)	M₁ .28 (7.0)	N .48 (12)	P 1.32 (34)
Q .98 (24.9)	R 2.10 (53)	S .75 (19)	T .21 (5.4)	U .59 (15)
V .08 (2.0)	W .11 (2.9)	X .16 (4.0)		

Inches (mm)

Valve Weight

Grommet..... 4 oz (.11 Kg)

DIN 4 oz (.11 Kg)

Conduit 5 oz (.14 Kg)

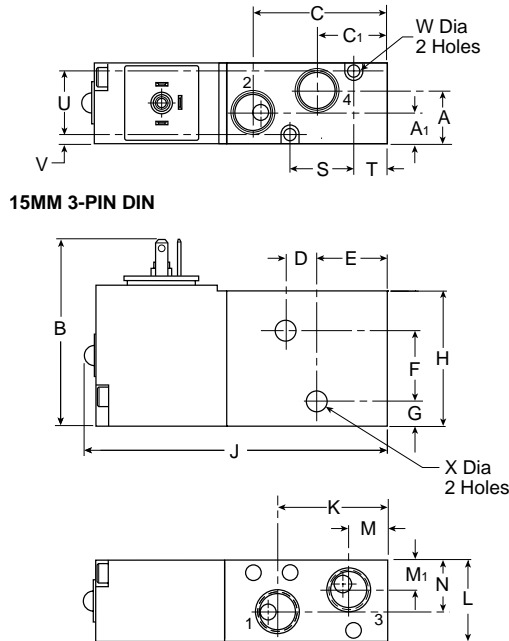
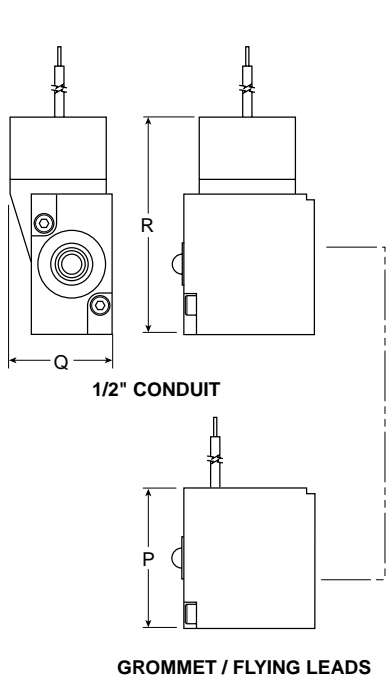

XM 4-Way Inline

A .48 (12)	A₁ .28 (6.9)	B 1.69 (43)	C 1.23 (31)	C₁ .64 (16)
D .24 (6.5)	E .68 (17)	F .65 (16.5)	G .22 (5.6)	H 1.25 (32)
J 2.80 (71)	K 1.01 (26)	L .75 (19)	M .36 (9.1)	M₁ .28 (7.1)
N .48 (12)	P 1.32 (34)	Q .98 (25)	R 2.10 (53)	S .59 (15)
T .32 (8.0)	U .59 (15)	V .08 (2.0)	W .11 (2.9)	X .16 (4.0)

Inches (mm)

Valve Weight

Grommet..... 4.3 oz (.12 Kg)

DIN 4.3 oz (.12 Kg)

Conduit 5.3 oz (.15 Kg)



**XM 4-Way Inline
with Flow Controls**

A	A ₁	B	C	C ₁
.48 (12)	.28 (6.9)	1.69 (43)	1.23 (31)	.64 (16)
D	E	F	G	H
.24 (6.5)	.68 (17)	.65 (16.5)	.22 (5.6)	1.25 (32)
J	K	L	M	M ₁
2.80 (71)	1.01 (26)	.75 (19)	.36 (9.1)	.28 (7.1)
N	P	Q	R	S
.48 (12)	1.32 (34)	.98 (25)	2.10 (53)	.59 (15)
T	U	V	W	X
.32 (8.0)	.59 (15)	.08 (2.0)	.11 (2.9)	.16 (4.0)

Inches (mm)
Valve Weight
Grommet..... 4.3 oz (.12 Kg)
DIN 4.3 oz (.12 Kg)
Conduit..... 5.3 oz (.15 Kg)

Mounting Bracket Dimensions

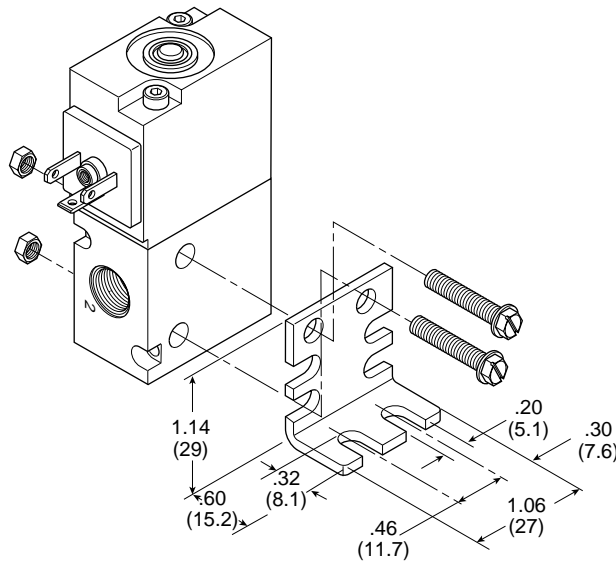

A

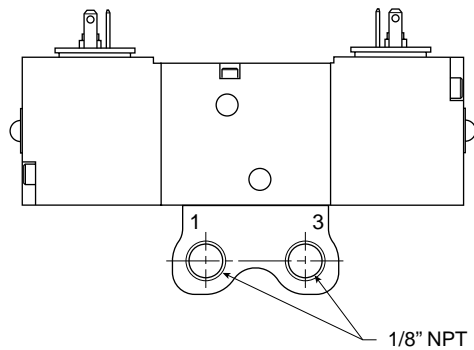
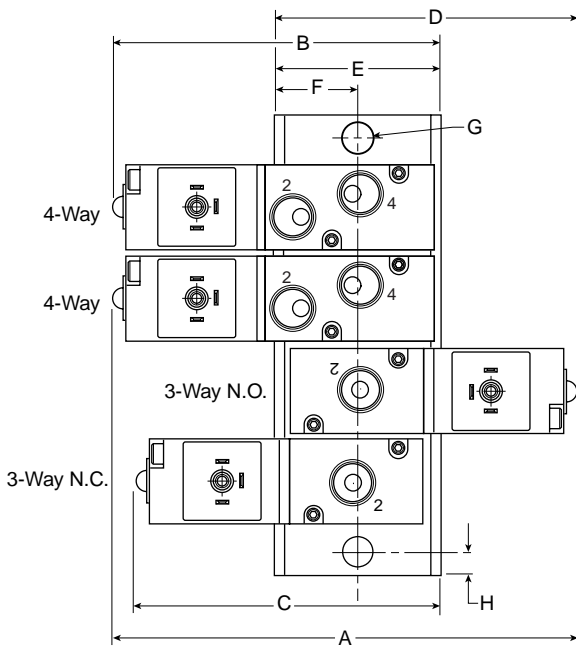

XM IEM Manifold

A	B	C	D	E
4.04 (103)	2.86 (73)	2.67 (68)	2.67 (68)	1.47 (37)
F	G	H	J	L
.74 (19)	Ø .28 (7.0)	.20 (5.0)	2.11 (54)	.79 (20)
M	N	P	Q	
.80 (20.5)	.48 (12)	.88 (22)	.44 (11)	

Inches (mm)

Manifold Weight

2 Station 2.5 oz (.07 Kg)
 Each Additional 1 oz (.03 Kg)

Valve Weight

3-Way 4 oz (.11 Kg)
 4-Way 4.3 oz (.12 Kg)

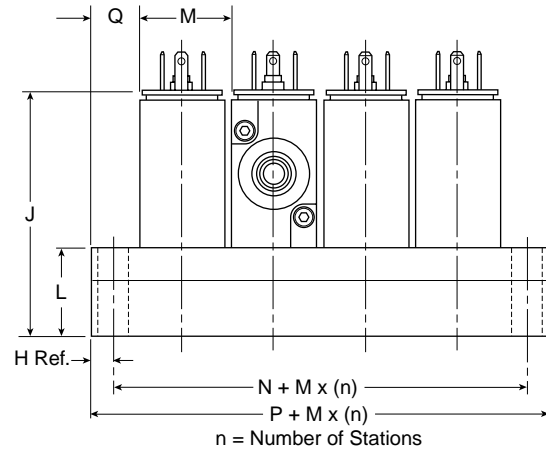



XM Subbase

A 1.62 (41)	B 2.00 (51)	C 1.58 (40)	D .92 (23)	E .85 (22)
F 1.19 (30)	G .61 (16)	H 1.26 (32)	J 1.70 (43)	K 3.25 (83)
L 2.85 (72)	M .75 (19)	N .44 (11)	P .28 (7.0)	Q 1.25 (32)
R .22 (5.6)	S .44 (11)	T .88 (22)	U .51 (13)	

Inches (mm)

Subbase Weight

Single Subbase 3.2 oz (.09 Kg)
End Plates 3.2 oz (.09 Kg)

Valve Weight

3-Way 3.7 oz (.10 Kg)
4-Way 4.6 oz (.13 Kg)

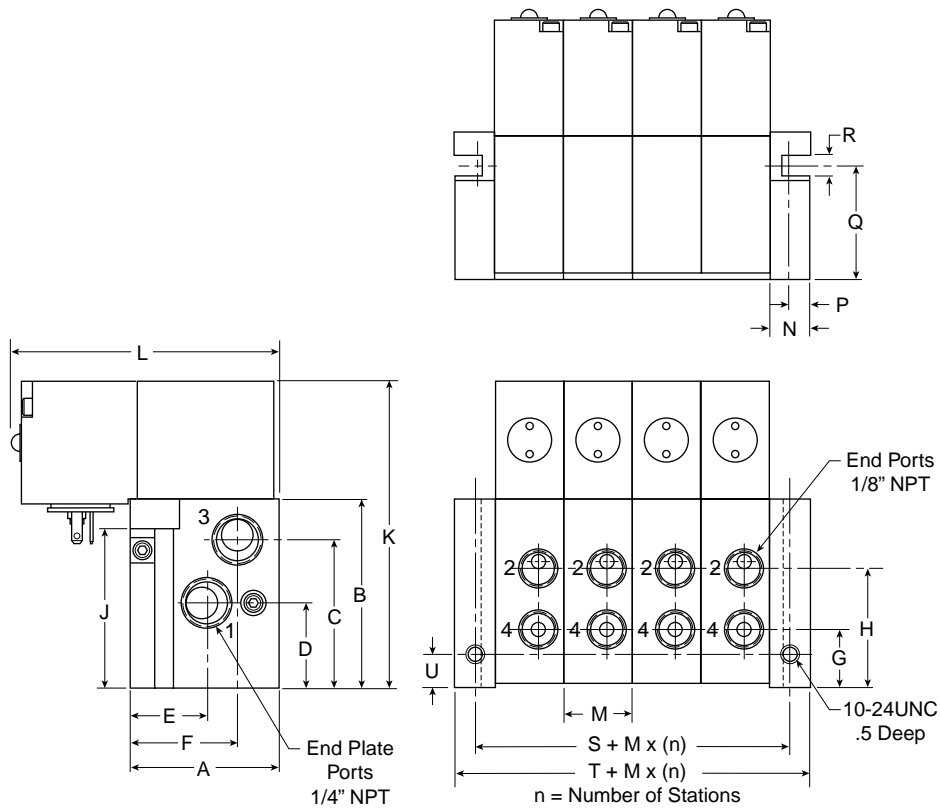

Notes

A



Air Control Valves

P2LAX – 1/8"

P2LBX – 1/4"

P2LCX – 3/8"

P2LDX – 1/2"

Section B

www.parker.com/pneu/vikingx

B

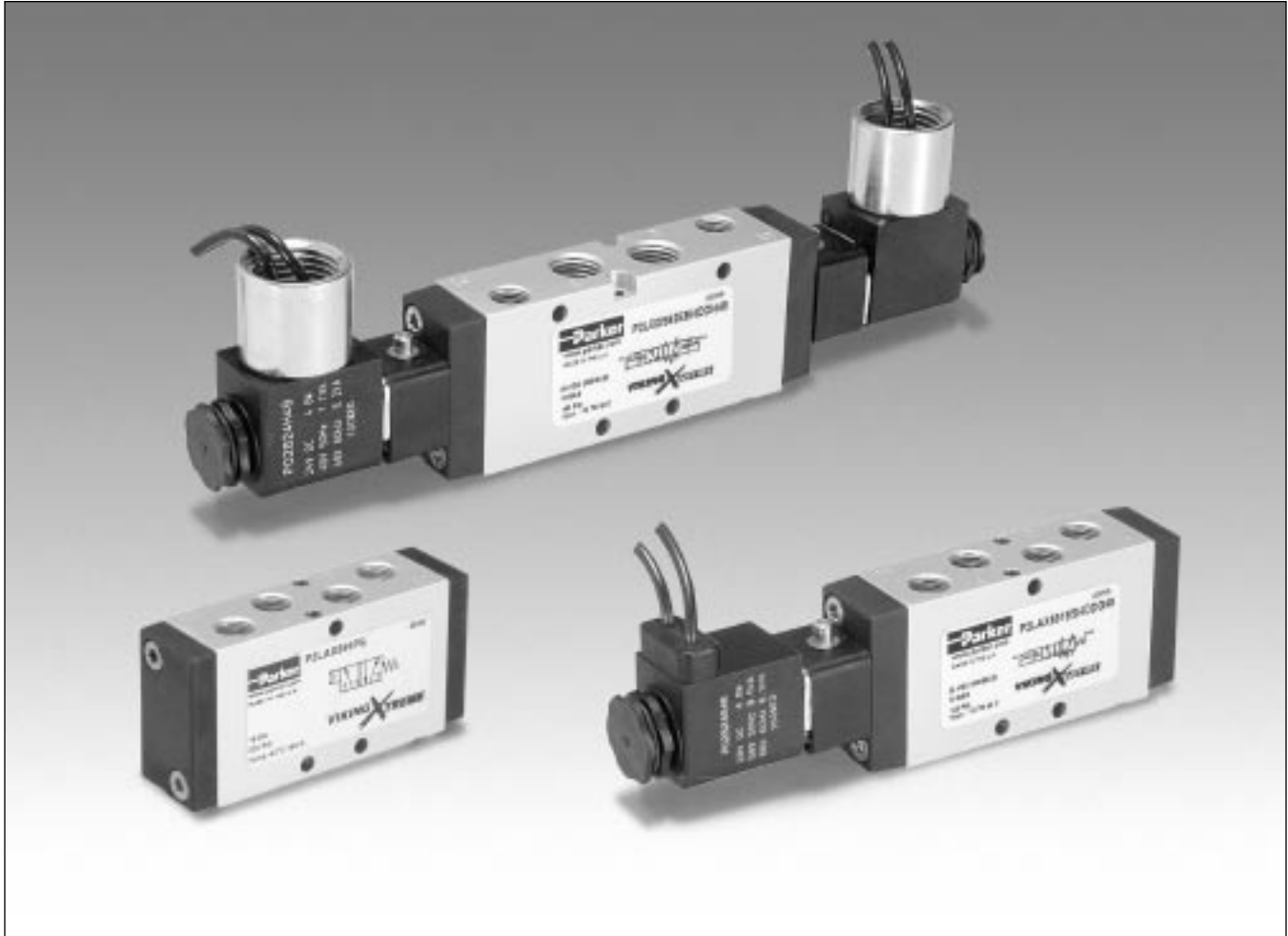

Basic Valve Functions	B2	IEM Bar Manifolds, Assemblies & Accessories	B10
Basic Valve Features	B3	22mm Solenoid Pilot Operators & Solenoid Kits	B11-B12
Xtreme Operation		ATEX Complete Valve & Solenoid Pilot Assemblies	B13
Solenoid Common Part Numbers	B4	Intrinsically Safe & Hazardous Duty Solenoid	B14
Solenoid Model Number Index	B5	Technical Data	B15
Remote Air Pilot Common Part Numbers	B6	Electrical Connectors / Accessories	B16-B17
Manual & Remote Air Pilot Model Number Index	B7	DOT Fittings	B18-B19
Lever Operated Common Part Numbers	B7	Dimensions	B20-B26
Normal Operation			
Solenoid Common Part Numbers	B8		
Solenoid Model Number Index	B9		

BOLD ITEMS ARE MOST POPULAR.





Single Solenoid

Single Pressure At Inlet Port 1:

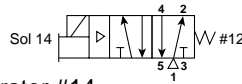

De-energized position – Solenoid operator #14 de-energized. Pressure at inlet port 1 connected to outlet port 2. Outlet port 4 connected to exhaust port 5.
Energized position – Solenoid operator #14 energized. Pressure at inlet port 1 connected to outlet port 4. Outlet port 2 connected to exhaust port 3.

Single Remote Pilot

Single Pressure At Inlet Port 1:

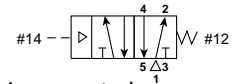

Normal position – Pressure at inlet port 1 connected to outlet port 2. Outlet port 4 connected to exhaust port 5.
Operated position – Maintained air signal at port 14. Pressure at inlet port 1 connected to outlet port 4. Outlet port 2 connected to exhaust port 3.

Double Solenoid

Single Pressure At Inlet Port 1:

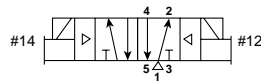

Solenoid operator #14 energized last. Pressure at inlet port 1 connected to outlet port 4. Outlet port 2 connected to exhaust port 3.
Solenoid operator #12 energized last. Pressure at inlet port 1 connected to outlet port 2. Outlet port 4 connected to exhaust port 5.

Double Remote Pilot

Single Pressure At Inlet Port 1:

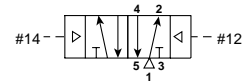

Momentary air signal at port 14 last. Pressure at inlet port 1 connected to outlet port 4. Outlet port 2 connected to exhaust port 3.
Momentary air signal at port 12 last. Pressure at inlet port 1 connected to outlet port 2. Outlet port 4 connected to exhaust port 5.

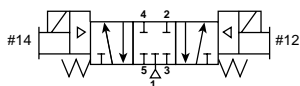

All Ports Blocked

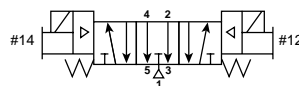

Center Exhaust

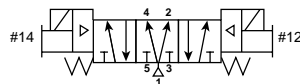

Pressure Center

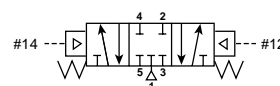

All Ports Blocked

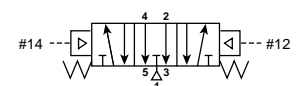

Center Exhaust

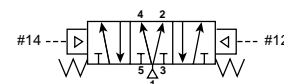

Pressure Center

Double Solenoid 3-Position

With #12 operator energized – inlet port 1 connected to cylinder port 2, cylinder port 4 connected to exhaust port 5.

With #14 operator energized – inlet port 1 connected to cylinder port 4, cylinder port 2 connected to exhaust port 3.

Closed Center

All ports blocked in the center position.

Vented Center

Cylinder ports 2 and 4 connected to exhaust ports 3 and 5 in center position. Port 1 is blocked.

Pressurized Center

Pressure port 1 connected to cylinder ports 2 and 4, and exhaust ports 3 and 5 blocked in center position.

Double Remote Pilot 3-Position

With #12 operator signaled – inlet port 1 connected to cylinder port 2, cylinder port 4 connected to exhaust port 5.

With #14 operator signaled – inlet port 1 connected to cylinder port 4, cylinder port 2 connected to exhaust port 3.

Closed Center

All ports blocked in the center position.

Vented Center

Cylinder ports 2 and 4 connected to exhaust ports 3 and 5 in center position. Port 1 is blocked.

Pressurized Center

Pressure port 1 connected to cylinder ports 2 and 4, and exhaust ports 3 and 5 blocked in center position.



Specifications

P2LAX	P2LAX: 0.7 Cv
P2LBX	P2LBX: 1.3 Cv
P2LCX	P2LCX: 2.5 Cv
P2LDX	P2LDX: 2.7 Cv

Materials of Construction

- Valve Body: Anodized Aluminum
- Spool: Aluminum & Nitrile Rubber
- End Caps: Anodized Aluminum
- Coils: Thermoplastic
- Fasteners: Stainless Steel

Operating Temperature

- Normal: 14°F to 122°F
 (-10°C to 50°C)
- Xtreme: -40°F to 140°F
 (-40°C to 60°C)

Operating Pressure

- Normal: Vacuum to 145 PSIG
 (Vacuum to 10 bar)
- Xtreme:
 - (P2LAX & P2LBX) Vacuum to 232 PSIG
 (Vacuum to 16 bar)
 - (P2LCX & P2LDX) Vacuum to 174 PSIG
 (Vacuum to 12 bar)



Ports

P2LAX	P2LAX: 1/8" NPT & BSPP
P2LBX	P2LBX: 1/4" NPT & BSPP
P2LCX	P2LCX: 3/8" NPT & BSPP
P2LDX	P2LDX: 1/2" NPT & BSPP



Compliance / Approval

- IP65 Rated
- ATEX Option Available

Solenoids

- 2.5 to 7.3 Watt – Conduit, Grommet, 22mm & 30mm 3-Pin (DIN 43650), Hazardous Duty, Intrinsically Safe
- 12VDC to 240VAC

Mounting

- Inline
- IEM Aluminum Bar

Mobile Applications

- Viking Xtreme Tested to +5g Shock and Vibration
- Solenoids Operate with Wide Voltage Tolerance Bands
- Corrosion Resistant Design

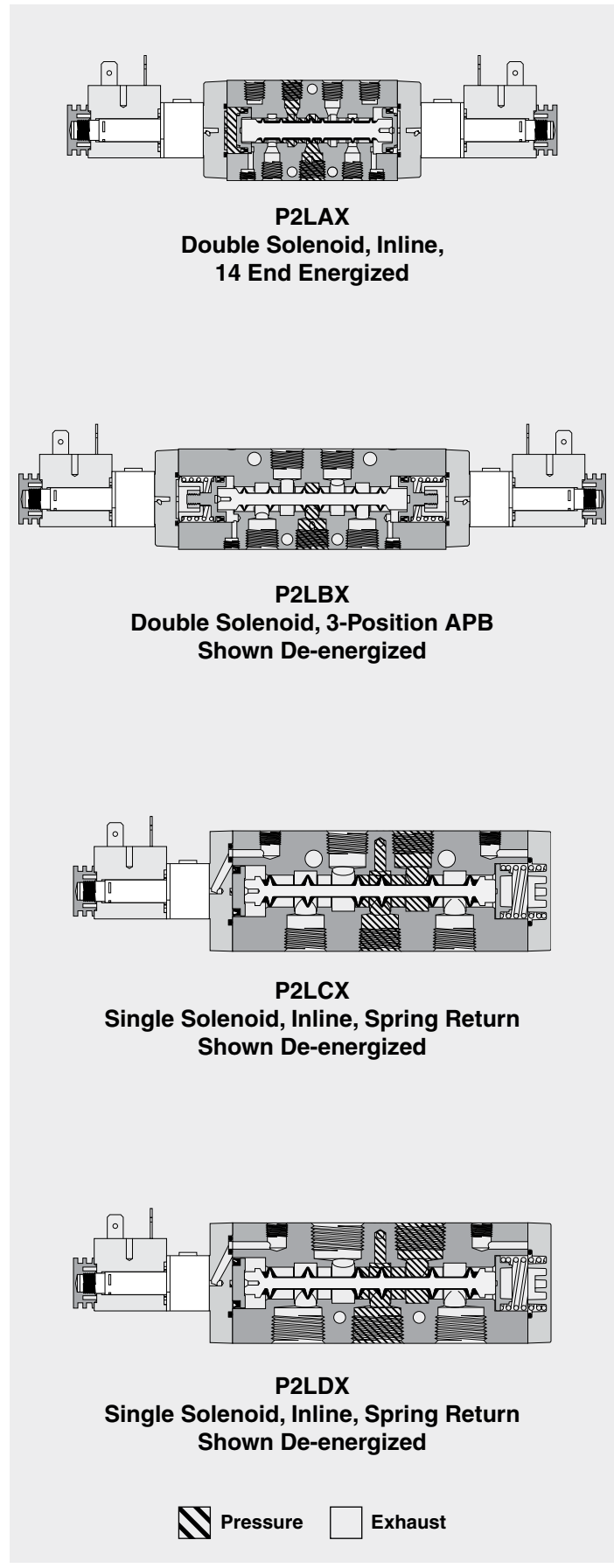



**Single Solenoid
2-Position**



**Double Solenoid
2-Position**

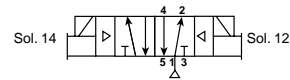
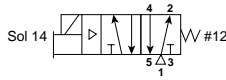

B

P2LAX	P2LAX591ESHDDDB47	12VDC	0.7 Cv
	P2LAX591ESHDDG47	24VDC	
	P2LAX591ESHDDDB48		
	P2LAX591ESHDDG48		
P2LBX	P2LBX592ESHDDDB47	12VDC	1.3 Cv
	P2LBX592ESHDDG47	24VDC	
	P2LBX592ESHDDDB48		
	P2LBX592ESHDDG48		
P2LCX	P2LCX593ESHDDDB47	12VDC	2.5 Cv
	P2LCX593ESHDDG47	24VDC	
	P2LCX593ESHDDDB48		
	P2LCX593ESHDDG48		
P2LDX	P2LDX594ESHDDDB47	12VDC	2.7 Cv
	P2LDX594ESHDDG47	24VDC	
	P2LDX594ESHDDDB48		
	P2LDX594ESHDDG48		

P2LAX	P2LAX591EEHDDDB47	12VDC	0.7 Cv
	P2LAX591EEHDDG47	24VDC	
	P2LAX591EEHDDDB48		
	P2LAX591EEHDDG48		
P2LBX	P2LBX592EEHDDDB47	12VDC	1.3 Cv
	P2LBX592EEHDDG47	24VDC	
	P2LBX592EEHDDDB48		
	P2LBX592EEHDDG48		
P2LCX	P2LCX593EEHDDDB47	12VDC	2.5 Cv
	P2LCX593EEHDDG47	24VDC	
	P2LCX593EEHDDDB48		
	P2LCX593EEHDDG48		
P2LDX	P2LDX594EEHDDDB47	12VDC	2.7 Cv
	P2LDX594EEHDDG47	24VDC	
	P2LDX594EEHDDDB48		
	P2LDX594EEHDDG48		

**Double Solenoid
3-Position All Ports Blocked
3-Position Center Exhaust**

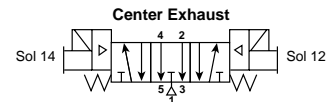
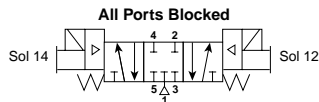
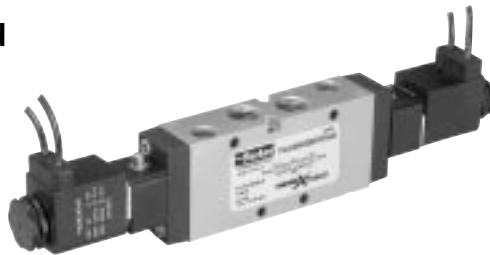

All Ports Blocked			
P2LAX	P2LAX691EEHDDG47	12VDC	0.5 Cv
	P2LAX691EEHDDG48	24VDC	
P2LBX	P2LBX692EEHDDG47	12VDC	0.9 Cv
	P2LBX692EEHDDG48	24VDC	
P2LCX	P2LCX693EEHDDG47	12VDC	1.8 Cv
	P2LCX693EEHDDG48	24VDC	
P2LDX	P2LDX694EEHDDG47	12VDC	1.9 Cv
	P2LDX694EEHDDG48	24VDC	

Center Exhaust			
P2LAX	P2LAX891EEHDDG47	12VDC	0.5 Cv
	P2LAX891EEHDDG48	24VDC	
P2LBX	P2LBX892EEHDDG47	12VDC	0.9 Cv
	P2LBX892EEHDDG48	24VDC	
P2LCX	P2LCX893EEHDDG47	12VDC	1.8 Cv
	P2LCX893EEHDDG48	24VDC	
P2LDX	P2LDX894EEHDDG47	12VDC	1.9 Cv
	P2LDX894EEHDDG48	24VDC	

NOTE: See Page B5 for Valve Description.





Single & Double Solenoid Operated Valves

Vacuum to 232 PSIG (Vacuum to 16 bar)

-40°F to 158°F (-40°C to 70°C)



P2L A X 5 91 E S H D D G 47

Valve Size	
1/8"	A
1/4"	B
3/8"	C*
1/2"	D*

*See Note Below for Pressure rating.

Voltage / Frequency	
42	24VAC
45	12VDC
47*	12 VDC Mobile
48*	24 VDC Mobile
49	24VDC
53	120VAC
57	240VAC
Blank	Valve Less Coil

* Only Available with Enclosures "A", "B" & "G".
Additional voltages are available upon request.
Contact Customer Support for more information.

Valve Type / Function	
<i>Internal Pilot Supply to Solenoid</i>	
2-Position Valve	5
3-Position Valve APB	6
3-Position Valve PC	7
3-Position Valve CE	8
<i>External Pilot Supply to Solenoids through Ports #12 & #14</i>	
2-Position Valve	N
3-Position Valve APB	P
3-Position Valve PC	Q
3-Position Valve CE	R

Enclosures / Lead Length	
A	30mm Square 3-Pin – ISO 4400 Form A (Male Only)
B	22mm Rectangular 3-Pin – Type B Industrial (Male Only)
G	Grommet - 18" Leads
H	1/2" NPT Conduit - 18" Leads
N	Solenoid Pilot Operator Less Coil

Main Port Thread	
G1/8 (P2LA)	11
G1/4 (P2LB)	12
G3/8 (P2LC)	13
G1/2 (P2LD)	14
1/8" NPT (P2LA)	91
1/4" NPT (P2LB)	92
3/8" NPT (P2LC)	93
1/2" NPT (P2LD)	94

Overrides	
D	Extended, Non-Locking
A	No Override
H	Heavy Duty, Locking

Solenoid Pilot Type	
D	Vented Pilot Exhaust
N	Tapped Pilot Exhaust (M5)

12 End Operator	
Double Solenoid Operated Valve	E
Single Solenoid Spring Return	S*

*Not Available with 3-Position Valves.

NOTE: P2LCX and P2LDX Solenoid Operated Valves have a maximum pressure rating of 175 PSIG (12 bar).

BOLD ITEMS ARE MOST POPULAR.





**Single Remote Pilot
 2-Position**



**Double Remote Pilot
 2-Position**

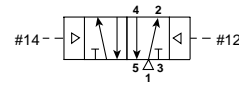
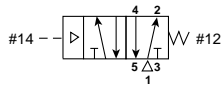
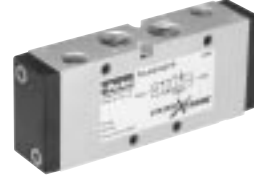

P2LAX	P2LAX591PS	0.7 Cv
P2LBX	P2LBX592PS	1.3 Cv
P2LCX	P2LCX593PS	2.5 Cv
P2LDX	P2LDX594PS	2.7 Cv

P2LAX	P2LAX591PP	0.7 Cv
P2LBX	P2LBX592PP	1.3 Cv
P2LCX	P2LCX593PP	2.5 Cv
P2LDX	P2LDX594PP	2.7 Cv

**Double Remote Pilot
 3-Position All Ports Blocked
 3-Position Center Exhaust**

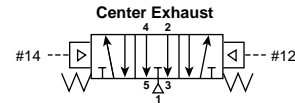
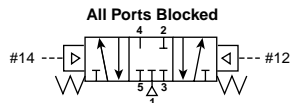

All Ports Blocked		
P2LAX	P2LAX691PP	0.5 Cv
P2LBX	P2LBX692PP	0.9 Cv
P2LCX	P2LCX693PP	1.8 Cv
P2LDX	P2LDX694PP	1.9 Cv

Center Exhaust		
P2LAX	P2LAX891PP	0.5 Cv
P2LBX	P2LBX892PP	0.9 Cv
P2LCX	P2LCX893PP	1.8 Cv
P2LDX	P2LDX894PP	1.9 Cv

NOTE: See Page B7 for Valve Description.





Manual & Remote Air Pilot Operated Valves

Vacuum to 232 PSIG (Vacuum to 16 bar)

-40°F to 158°F (-40°C to 70°C)



P2L A X 5 91 PS

Valve Size	
1/8"	A
1/4"	B
3/8"	C*
1/2"	D*

*See Note Below for Pressure rating.

Valve Type / Function	
2-Position Valve	5
3-Position Valve APB	6
3-Position Valve PC*	7
3-Position Valve CE	8

Note: Not Available with Lever Operated.

Operators / Return	
PP	Double Remote Pilot
PS*	Single Remote Pilot, Spring Return
VS*	Spring Return Lever, 2-Position, 90° to Ports, P2LA Only
VV*	Lever, Detent, 2-Position, 90° to Ports, P2LA Only
11	Spring Centered Lever, 3-Position, 90° to Ports, P2LA Only
22	Lever, Detent, 3-Position, 90° to Ports, P2LA Only

* Not Available with 3-Position Valves.

Main Port Thread	
11	G1/8 (P2LA)
12	G1/4 (P2LB)
13	G3/8 (P2LC)
14	G1/2 (P2LD)
91	1/8" NPT (P2LA)
92	1/4" NPT (P2LB)
93	3/8" NPT (P2LC)
94	1/2" NPT (P2LD)

BOLD ITEMS ARE MOST POPULAR.

Lever Operated 2-Position

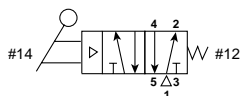

P2LAX	P2LAX591VS	Spring Return	0.7 Cv
	P2LAX591VV	Detent	

Lever Operated 3-Position

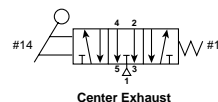
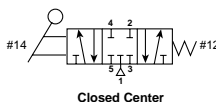

All Ports Blocked			
P2LAX	P2LAX69111	Spring-Centered	0.5 Cv
	P2LAX69122	Detent	
Center Exhaust			
P2LAX	P2LAX89111	Spring-Centered	0.5 Cv
	P2LAX89122	Detent	

NOTE: P2LCX and P2LDX Manual & Remote Air Pilot Valves have a maximum pressure rating of 175 PSIG (12 bar).





**Single Solenoid
 2-Position**

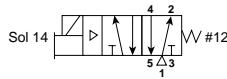

**Double Solenoid
 2-Position**

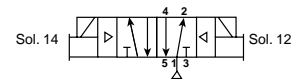
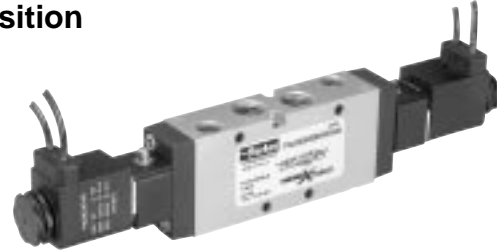

B

P2LAX	P2LAX591ESNDDDB49	24VDC	0.7 Cv
	P2LAX591ESNDDG49	120VAC	
	P2LAX591ESNDDDB53		
	P2LAX591ESNDDG53		
P2LBX	P2LBX592ESNDDDB49	24VDC	1.3 Cv
	P2LBX592ESNDDG49	120VAC	
	P2LBX592ESNDDDB53		
	P2LBX592ESNDDG53		
P2LCX	P2LCX593ESNDDDB49	24VDC	2.5 Cv
	P2LCX593ESNDDG49	120VAC	
	P2LCX593ESNDDDB53		
	P2LCX593ESNDDG53		
P2LDX	P2LDX594ESNDDDB49	24VDC	2.7 Cv
	P2LDX594ESNDDG49	120VAC	
	P2LDX594ESNDDDB53		
	P2LDX594ESNDDG53		

P2LAX	P2LAX591EENDDDB49	24VDC	0.7 Cv
	P2LAX591EENDDG49	120VAC	
	P2LAX591EENDDDB53		
	P2LAX591EENDDG53		
P2LBX	P2LBX592EENDDDB49	24VDC	1.3 Cv
	P2LBX592EENDDG49	120VAC	
	P2LBX592EENDDDB53		
	P2LBX592EENDDG53		
P2LCX	P2LCX593EENDDDB49	24VDC	2.5 Cv
	P2LCX593EENDDG49	120VAC	
	P2LCX593EENDDDB53		
	P2LCX593EENDDG53		
P2LDX	P2LDX594EENDDDB49	24VDC	2.7 Cv
	P2LDX594EENDDG49	120VAC	
	P2LDX594EENDDDB53		
	P2LDX594EENDDG53		

**Double Solenoid
 3-Position All Ports Blocked
 3-Position Center Exhaust**

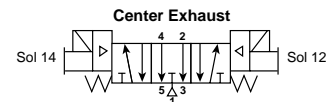
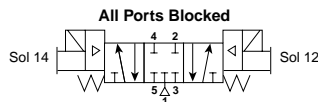
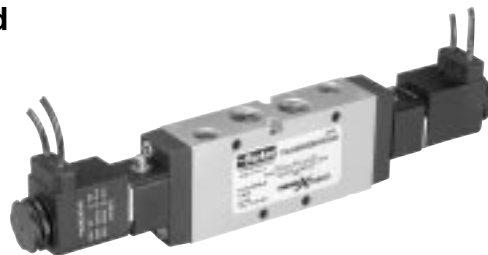

All Ports Blocked			
P2LAX	P2LAX691EENDDG49	24VDC	0.5 Cv
	P2LAX691EENDDG53	120VAC	
P2LBX	P2LBX692EENDDG49	24VDC	0.9 Cv
	P2LBX692EENDDG53	120VAC	
P2LCX	P2LCX693EENDDG49	24VDC	1.8 Cv
	P2LCX693EENDDG53	120VAC	
P2LDX	P2LDX694EENDDG49	24VDC	1.9 Cv
	P2LDX694EENDDG53	120VAC	

Center Exhaust			
P2LAX	P2LAX891EENDDG49	24VDC	0.5 Cv
	P2LAX891EENDDG53	120VAC	
P2LBX	P2LBX892EENDDG49	24VDC	0.9 Cv
	P2LBX892EENDDG53	120VAC	
P2LCX	P2LCX893EENDDG49	24VDC	1.8 Cv
	P2LCX893EENDDG53	120VAC	
P2LDX	P2LDX894EENDDG49	24VDC	1.9 Cv
	P2LDX894EENDDG53	120VAC	

NOTE: See Page B9 for Valve Description.





Single & Double Solenoid Operated Valves

Vacuum to 145 PSIG (Vacuum to 10 bar)

14°F to 122°F (-10°C to 50°C)

P2L A X 5 91 E S N D D G 49

Valve Size	
1/8"	A
1/4"	B
3/8"	C
1/2"	D

Voltage / Frequency	
42	24VAC
45	12VDC
47*	12 VDC Mobile
48*	24 VDC Mobile
49	24VDC
53	120VAC
57	240VAC
Blank	Valve Less Coil

Valve Type / Function	
<i>Internal Pilot Supply to Solenoid</i>	
2-Position Valve	5
3-Position Valve APB	6
3-Position Valve PC	7
3-Position Valve CE	8
<i>External Pilot Supply to Solenoids through Ports #12 & #14</i>	
2-Position Valve	N
3-Position Valve APB	P
3-Position Valve PC	Q
3-Position Valve CE	R

Main Port Thread	
G1/8 (P2LA)	11
G1/4 (P2LB)	12
G3/8 (P2LC)	13
G1/2 (P2LD)	14
1/8" NPT (P2LA)	91
1/4" NPT (P2LB)	92
3/8" NPT (P2LC)	93
1/2" NPT (P2LD)	94

Enclosures / Lead Length	
A	30mm Square 3-Pin – ISO 4400 Form A (Male Only)
B	22mm Rectangular 3-Pin – Type B Industrial (Male Only)
E*	Intrinsically Safe, FM / CSA
F	Hazardous Duty, FM / CSA
G	Grommet - 18" Leads
H	1/2" NPT Conduit - 18" Leads
N	Solenoid Pilot Operator Less Coil

Overrides	
A*	No Override
C	Flush - Locking
D	Extended Non-Locking

Solenoid Pilot Type	
D	Pilot Exhaust Vented
N	Tapped Pilot Exhaust (M5)

12 End Operator	
Double Solenoid Operated Valve	E
Single Solenoid Spring Return	S*

*Not Available with 3-Position Valves.

* Only Available with Enclosures "A", "B" & "G". Additional voltages are available upon request. Contact Customer Support for more information.

*Only Available with Voltage Code "49" & Override Option "A".

*Only Available with Enclosure Option "E".



BOLD ITEMS ARE MOST POPULAR.





BOLD ITEMS ARE MOST POPULAR,



AA P2LAX M A X N 04 N P

Manifold	
Manifold Only	Blank
Manifold with Valves Mounted	AA

Stations	
02	
•	
•	
12	

Series	
P2LAX Series*	
P2LBX Series*	
P2LCX Series	

* 30mm Solenoid Coil Option (Enclosure / Lead Length Option A) not available on IEM Bar Manifold P2LAX or P2LBX.

Port Type	
G	BSPP "G"
N	NPT

B

IEM Bar Manifolds

P2LAX

P2LBX

P2LCX

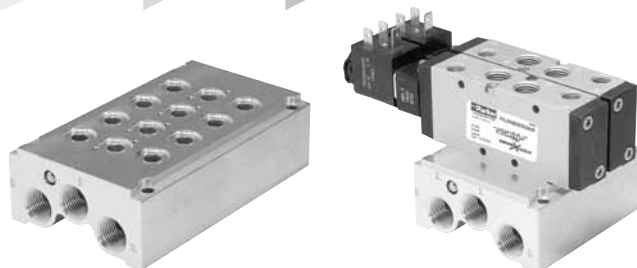

Manifold Only	Manifold Assembly	## – stations
P2LAXMAXN##NP	AAP2LAXMAXN##NP	02 to 12
P2LBXMAXN##NP	AAP2LBXMAXN##NP	02 to 12
P2LCXMAXN##NP	AAP2LCXMAXN##NP	02 to 12

- Utilizes Inline mount Viking Xtreme Series valves.
- Kits include:** (1) Manifold, (2) Valve Hold Down Bolts per Station, (3) O-rings per Station.

Note: All IEM bar manifolds are 4-Way only with internal pilot air supply. External pilot supply thru a common "X" port not available.

Blanking Plate

	Type		Kit number
	P2LAX	4-way	P2LAXK20P
	P2LBX	4-way	P2LBXK20P
	P2LCX	3 & 4 way	P2LCXK20P
	P2LAX	3-way	P2LAXK30P
	P2LBX	3-way	P2LBXK30P

Kit includes: (1) Plate, (2) Screws, (3) O-rings

Manifold Bolts

Type	Kit Number	Qty.
P2LAX	P2LAXK87P	12
P2LBX	P2LBXK87P	12
P2LCX	P2LCXK87P	12

Manifold O-rings

Type	Kit Number	Qty.
P2LAX	P2LAXK84P	30
P2LBX	P2LBXK84P	18
P2LCX	P2LCXK84P	12



22mm Solenoid Pilot Operators & Coils

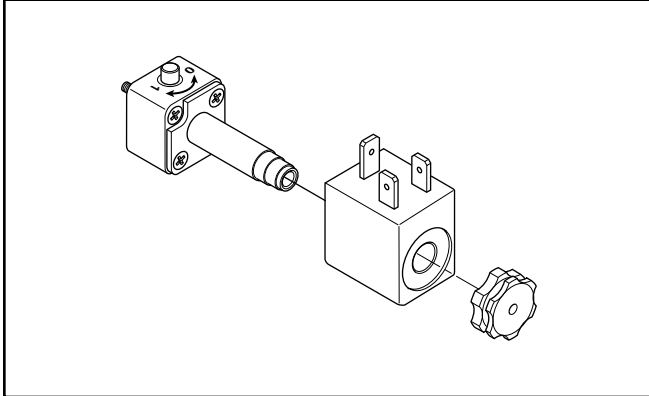

22mm Solenoid Pilot Options

The P2FP13*4* (NC) 3/2 solenoid pilot operators are designed for piloting pneumatic control valves with compressed air or other inert gases.

The P2FP operator is available for Normal operating pressures up to 10 bar or the Xtreme maximum operating pressure of 16 bar and wide band voltage tolerances required for mobile applications.

Corrosion Resistant Design

The pilot valve body is manufactured in thermoplastic PA6 material and the core tube brass / stainless steel. The plunger / core is made from stainless steel and the valve seats from FKM.

Solenoid Pilot Exhaust

These operators all exhaust out of the top of the core tube which is tapped M5. The standard solenoid nut fitted to the core tube is a diffuser nut which allows the exhaust to escape to atmosphere. This nut also minimizes ingress of dirt into the valve through this port. The alternative plastic knurled nut can be specified (refer to part number system) if the exhaust air needs captured and piped away using the M5 tapped port.

Mobile Applications

Viking Xtreme valves are tested to +5g shock and vibration. Solenoid operated valves are designed to operate with wide voltage tolerance bands within the ambient temperature ranges stated in the technical section.

Coils

Coils are wound with enameled copper wire, having a temperature index of 1800C with class F insulation (1550C) and are encapsulated in Thermoplastic resin. When fitted with suitable connector and correct gasket, they give protection to IP65.

ATEX



ATEX is a European Directive (94/9/EC) valid for products to be used within an explosive atmosphere.

Both ATEX certified solenoid, remote pilot and manual operated valves, as well as complete solenoid pilot assemblies are available. See page B13 for a complete list of valves available. For specific information regarding ATEX certification please visit www.parker.com/pneumatics.



Manual Override Options

The pilot operators can be supplied with locking or non-locking manual override. The standard manual override is the monostable (spring return) extended brass override. Alternatively the bistable (locking) override can be specified as an alternative for the Normal duty 10 bar option.

Spares

Solenoid operators are available as spares complete with mounting screws and seals. Coils and connectors should be ordered separately unless ATEX certified and intrinsically safe is needed. ATEX certified operators and coils must be ordered together.

Transients

Interrupting the current through the solenoid coil produces momentary voltage peaks which, under unfavorable conditions, can amount to several hundred times the rated operating voltage. Normally, these transients do not cause problems, but to achieve the maximum life of relays in the circuit (and particularly of transistors, thyristors and integrated circuits) it is desirable to provide protection by means of voltage-dependent resistors (varistors). All connectors / cable plugs with LEDs include this type of circuit protection.

Materials

Pilot Valve

Body	Polyamide
Armature Tube:	
Normal Pilot Operator.....	Brass
Extreme Pilot Operator.....	Stainless Steel
Plunger & Core.....	Corrosion resistant Cr-Ni Steel
Seals.....	FKM (Viton™)
Screws.....	Stainless Steel

Coil

Encapsulation Material.....	Thermoplastic
-----------------------------	---------------



Pilot Operator Kits

P2F P 1 3 N 4 C

Type	
Pilot Operator Kit	P

Overrides	
C*	Locking (Bistable) Flush - Plastic
D	Non-Locking (Monostable) Extended - Brass

*Only Available with "N" Pressure / Temperature Option.

Pressure / Temperature	
145 PSIG (10 bar) 14°F to 122°F (-10°C to 50°C)	N
232 PSIG (16 bar) -40°F to 158°F (-40°C to 70°C)	H

B

Solenoid Kits

P2F C A 4 49

Type	
Solenoid Kit	C

Voltage / Frequency	
42	24VAC
45	12VDC
47*	12 VDC Mobile
48*	24 VDC Mobile
49	24VDC
53	120VAC
57	240VAC
Blank	Valve Less Coil

Enclosures / Lead Length	
30mm Square 3-Pin – ISO 4400 Form A (Male Only)	A
22mm Rectangular 3-Pin – Type B Industrial (Male Only)	B
Hazardous Duty, FM / CSA	F*
Grommet - 18" Leads	G
1/2" NPT Conduit - 18" Leads	H
Grommet 72" Leads	Q
1/2" Conduit 72" Leads	R

* Only Available with Voltage Codes "45", "49", "53" & "57". Not for use with the Xtreme Version (-40°C to 70°C).

* Only Available with Enclosures "A", "B" & "G". Additional voltages are available upon request. Contact Customer Support for more information.

Solenoid Enclosures



Option A
 30mm Square,
 3-Pin ISO 4400, DIN 43650A



Option B
 22mm Rectangular,
 3-Pin DIN, Type B Industrial



Option G & Q
 Grommet, 18" or 72" Leads



Option H & R
 1/2" Conduit, 18" or 72" Leads

Solenoid Information (Solenoids are rated for continuous duty.)

Code	Voltage			Enclosure "A"		Enclosure "B" to "R"	
	AC		DC	Power Consumption	Holding (Amps)	Power Consumption	Holding (Amps)
	60Hz	50Hz					
42	24	22		3.9VA	.14	7.3VA	.31
45	—	—	12	2.6W	.21	4.6W	.37
47*	—	—	12	6.2W	.52	5.5W	.46
48*	—	—	24	6.8W	.29	6.0W	.25
49	—	—	24	2.7W	.11	4.8W	.20
53	120	110	—	4.1VA	.04	6.3VA	.05
57	240	230	—	3.7VA	.02	6.4VA	.03

* Mobile voltages. Solenoid Voltage Characteristics for all coils located on page 19.

BOLD OPTIONS ARE MOST POPULAR



ATEX Certified Single & Double Solenoid Operated Valves
Vacuum to 145 PSIG (Vacuum to 10 bar)
14°F to 122°F (-10°C to 50°C)

P2L A X 5 91 E S A D D M 49

Valve Size	
1/8"	A
1/4"	B
3/8"	C
1/2"	D

Voltage	
49	24VDC

Enclosures	
M	ATEX 8-22T EExm T4 135°C
S	ATEX 8-30T EExm T6 85°C

Valve Type / Function	
<i>Internal Pilot Supply to Solenoid</i>	
2-Position Valve	5
3-Position Valve APB	6
3-Position Valve PC	7
3-Position Valve CE	8
<i>External Pilot Supply to Solenoids through Ports #12 & #14</i>	
2-Position Valve	N
3-Position Valve APB	P
3-Position Valve PC	Q
3-Position Valve CE	R

Overrides	
D	Extended Non-Locking

Solenoid Pilot Type	
D	Vented Pilot Exhaust
N	Tapped Pilot Exhaust (M5)

12 End Operator	
E	Double Solenoid Operated Valve
S	Single Solenoid Spring Return

Main Port Thread	
G1/8 (P2LA)	11
G1/4 (P2LB)	12
G3/8 (P2LC)	13
G1/2 (P2LD)	14
1/8" NPT (P2LA)	91
1/4" NPT (P2LB)	92
3/8" NPT (P2LC)	93
1/2" NPT (P2LD)	94

NOTE: For ATEX Certified Manual and Remote Air Pilot Valves, build the valve part number from the model number index on page B7 and add "-EX" following the number.

Example: P2LAX591PS-EX

ATEX Certified Solenoid Pilot Assemblies

P2F S 1 3 A 3 D M 49

Overrides	
Extended, Non-Locking	D

Voltage	
49	24VDC

Enclosures	
M	ATEX 8-22T EExm T4 135°C
S	ATEX 8-30T EExm T6 85°C

NOTE: All Kits include a 3 Meter Sealed Cable with Assembly.





Intrinsically Safe Solenoid Valves (“E” Option)

Hazardous Location Class:

Class I; Groups A, B, C & D

Class II; Groups E, F, & G

Class III; Div. I

For use in low voltage (24VDC) Intrinsically Safe applications. NO OTHER VOLTAGE IS APPROVED.

Comes standard with non-lighted solenoid connector.

Must be connected to an FM approved Barrier.

For dimensions, reference standard solenoid models. Maximum internally piloted valve pressure is 115 PSIG. Pressures to 145 PSIG can be used when external pilot is utilized and pilot pressure is limited to 115 PSIG.

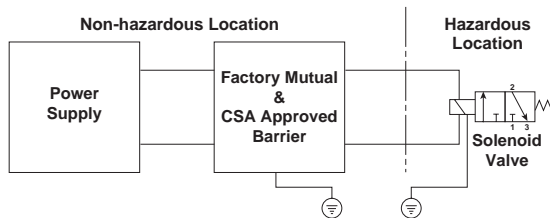

Intrinsically Safe Solenoid Pilot Assembly Kits

Part Number	Description
P2FS13N1AE49	24VDC

Hazardous Duty Solenoid Valves (“F” Option)

Hazardous Location Class:

Class I; Zone I EX, M, II & T4

Class I; Groups A, B, C, & D

Class II & III; Div. I, Groups E, F, & G

Comes standard with 1/2" conduit connection.

Voltage Range = +10% +/- 10%

Ambient Temp. Range = -20°C (-4°F) to 60°C (140°F)

Duty Factor = 100%

IP65 Rated (with Connected Conduit Connector)

Notes:

1. Maximum non-hazardous location voltage not to exceed 250V RMS.
2. Connect per Barrier Manufacturers instructions.
3. Factory Mutual requires connections per ISA RP 12.6 instructions.
4. CSA requires "Installation to be in accordance with the Canadian Electrical Code, Part I."



**Option F
 Hazardous Duty FM / CSA**

Internal to External Pilot Conversion (Size A & B Only)

To convert from Internal to External Pilot Valve, simply remove the (2) fasteners that attach the end cap to the valve body. Rotate the end cap 180° and attach back to the valve body. For single solenoid valves, only the 14-End needs to be rotated. For double solenoid valves, both ends must be converted for proper function.

The 12 & 14-Ports are always tapped no matter what Valve Type / Function is selected. For Internal Pilot Function, ports do NOT need to be plugged.

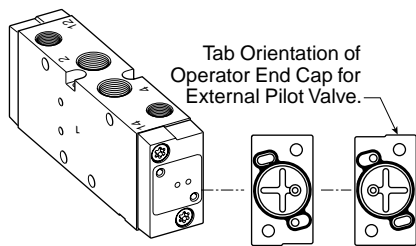

Tab Orientation of Operator End Cap for Internal Pilot Valve.

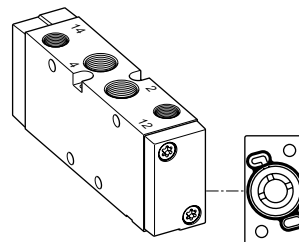

Tab Orientation of End Cap for Spring Return and External (Remote) Pilot Valve.



Operating Temperature

- **Normal**..... 14°F to 122°F (-10°C to 50°C)
- **Extreme**..... -40°F to 158°F (-40°C to 70°C)

Flow Rating

Valve Size	Port Size	2-Position	3-Position
P2LAX	1/8"	0.7	0.5
P2LBX	1/4"	1.3	0.9
P2LCX	3/8"	2.5	1.8
P2LDX	1/2"	2.7	1.9

Operating Pressure

Maximum: Normal.....145 PSIG (10 bar)
Extreme.....232 PSIG (16 bar)

Minimum:

Valve Type - Internal Pilot	Minimum PSIG (bar)			
	P2LAX	P2LBX	P2LCX	P2LDX
Single Sol - Spring Return	46 (3.2)	51 (3.5)	51 (3.5)	51 (3.5)
Single Remote Pilot - Spring Return	46 (3.2)	51 (3.5)	51 (3.5)	51 (3.5)
Double Solenoid - 2-Position	22 (1.5)	22 (1.5)	22 (1.5)	22 (1.5)
Double Remote Pilot - 2-Position	22 (1.5)	22 (1.5)	22 (1.5)	22 (1.5)
Double Solenoid - 3-Position (APB, PC, CE)	51 (3.5)	51 (3.5)	51 (3.5)	51 (3.5)
Double Remote Pilot - 3-Position (APB, PC, CE)	51 (3.5)	51 (3.5)	51 (3.5)	51 (3.5)

Valve Type - External Pilot	P2LAX	P2LBX	P2LCX	P2LDX
All Viking Series	Vacuum			

Response Time

Valve Size	Port Size	Volume			
		0 Cu. In. Test Chamber		20 Cu. In. Test Chamber	
		Fill (mSec)	Exhaust (mSec)	Fill (mSec)	Exhaust (mSec)
2-Position Single Solenoid / Spring Return					
P2LAX	1/8"	17.3	18.0	111.1	210.7
P2LBX	1/4"	19.4	19.7	62.8	92.2
2-Position Double Solenoid					
P2LAX	1/8"	12.0	12.9	108.7	213.7
P2LBX	1/4"	13.4	13.5	56.9	86.4

Solenoid Voltage Characteristics

Non-mobile Coils

+10% / -10% for all Coils with Normal and Extreme Operators

Mobile Coils - Normal Pilot Operator

22mm 12 & 24VDC - Mobile (47 & 48 Voltage Code)

Minimum Inlet Pressure (bar)	Operating Temperature		
	-10°C	+10°C	+50°C
3	+30 / -25%	+30 / -20%	+25 / -15%
6	+30 / -30%	+30 / -25%	+25 / -20%
8	+30 / -30%	+30 / -30%	+25 / -25%
10	+30 / -30%	+30 / -30%	+25 / -30%

30mm 12 & 24VDC - Mobile (47 & 48 Voltage Code)

Minimum Inlet Pressure (bar)	Operating Temperature		
	-10°C	+10°C	+50°C
3	+30 / -30%	+30 / -30%	+25 / -30%
6	+30 / -30%	+30 / -30%	+25 / -30%
8	+30 / -30%	+30 / -30%	+25 / -30%
10	+30 / -30%	+30 / -30%	+25 / -30%

Mobile Coils - Extreme Pilot Operator

22mm 12 & 24VDC - Mobile (47 & 48 Voltage Code)

Minimum Inlet Pressure (bar)	Operating Temperature			
	-40°C	+10°C	+50°C	+70°C
4	+30 / -25%	+30 / -25%	+30 / -10%	+20 / -10%
8	+30 / -30%	+30 / -25%	+30 / -15%	+20 / -15%
12	+30 / -30%	+30 / -30%	+30 / -15%	+20 / -15%
16	+30 / -30%	+30 / -30%	+30 / -20%	+20 / -20%

30mm 12 & 24VDC - Mobile (47 & 48 Voltage Code)

Minimum Inlet Pressure (bar)	Operating Temperature			
	-40°C	+10°C	+50°C	+70°C
4	+30 / -30%	+30 / -30%	+25 / -30%	+15 / -30%
8	+30 / -30%	+30 / -30%	+25 / -30%	+15 / -30%
12	+30 / -30%	+30 / -30%	+25 / -30%	+15 / -30%
16	+30 / -30%	+30 / -30%	+25 / -30%	+15 / -30%

Note: All table ratings are based on 100% continuous duty and 5G shock vibration. At 50% continuous duty all ratings are +30% / -30% for all Temperatures and Pressures.





Female Electrical Connectors / Accessories

30mm Square 3-Pin – ISO 4400, DIN 43650A (Use with Enclosure “A”)

Connector	Connector with 6' (2m) Cord	Description
PS2028BP	PS2028JBP	Unlighted
PS203279BP	PS2032J79BP*	Light – 6-48V, 50/60Hz, 6-48VDC
PS203283BP	PS2032J83BP*	Light – 120V/60Hz
PS203283BP	N/A	Light – 240V/60Hz

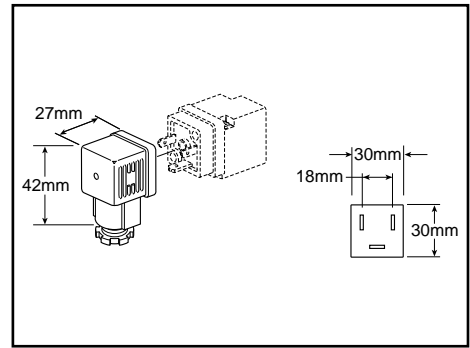

* LED with surge suppression.

Note: Max \varnothing 6.5mm cable size required for connector w/o 6' (2m) cord. IP65 rated when properly installed.

Engineering Data:

Conductors: 2 Poles Plus Ground; Cable Range (Connector Only): 8 to 10mm (0.31 to 0.39 Inch); Contact Spacing: 18mm

B

22mm Rectangular 3-Pin – Type B Industrial (Use with Enclosure “B”)

Connector	Connector with 6' (2m) Cord	Description
PS2429BP	PS2429JBP	Unlighted
PS243079BP	PS2430J79BP*	Light – 24V/60Hz, 24VDC
PS243083BP	PS2430J83BP*	Light – 120V/60Hz
PS243087BP	N/A	Light – 240V/60Hz

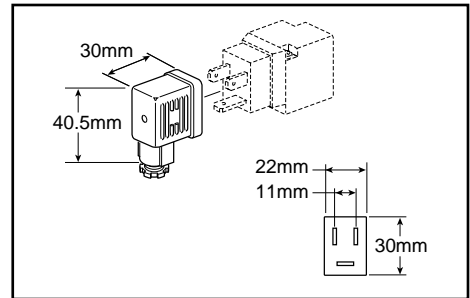

* LED with surge suppression.

Note: Max \varnothing 6.5mm cable size required for connector w/o 6' (2m) cord. IP65 rated when properly installed.

Engineering Data:

Conductors: 2 Poles Plus Ground; Cable Range (Connector Only): 6 to 8mm (0.24 to 0.31 Inch); Contact Spacing: 11mm

Exhaust Mufflers

Pipe Thread	Part Number
M5	P6M-PAC5
1/8" NPT	EM12
1/4" NPT	EM25
3/8" NPT	EM37
1/2" NPT	EM50

P6M - Plastic; EM - Sintered Bronze



Plastic Silencers

Thread Size	Part Number		A (mm)	B (mm)
	NPT	BSPT		
M5	AS-5		.43 (11)	.32 (8)
1/8"	ASN-6	AS-6	1.57 (40)	.63 (16)
1/4"	ASN-8	AS-8	2.56 (65)	.83 (21)
3/8"	ASN-10	AS-10	3.35 (85)	.98 (25)
1/2"	ASN-15	AS-15	3.74 (95)	1.18 (30)





Exhaust Protector

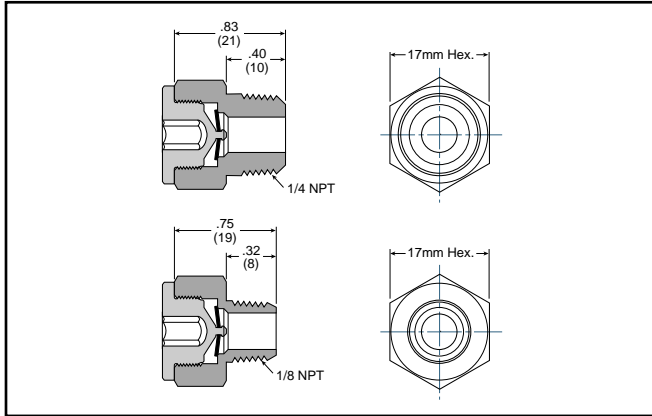

Specifications

Operating Pressure 0 – 150 PSIG
 (0 to 10 bar, 0 to 1034 kPa)

Operating Temperature -40°F to 158°F (-40°C to 70°C)

Material:

Body and Pipe Adapter Brass
 Membrane Fluorocarbon

Flow Data (SCFM)

Part Number	Size	60 PSIG Inlet	90 PSIG Inlet	125 PSIG Inlet
E90016	1/8"	40.1	56.5	75.5
E90017	1/4"	44.6	62.7	83.5

Features

- 1/8 and 1/4 NPT male sizes
- Fitted with a Brass Pipe Adapter and a Fluorocarbon Membrane
- Resistant to Rust, Clog, Wash Down and Contamination

Applications

These protectors are intended for mobile applications, quick venting applications and alternative exhaust port breathers that require protection against clogging.

Ideal for valves exposed to harsh environmental conditions (which can cause a “caking up” in the exhaust pipe ports where the bronze mufflers or breather vents are installed).

Particularly suitable for time-sensitive applications such as axle-lift suspensions or pushers or tag axles.





68PM Male Connector

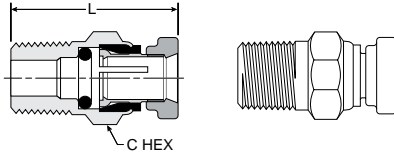

Part No.	Tube Size	Pipe Thread (NPTF)	C Hex	L
68PM-2-1	1/8	1/16	3/82	0.93
68PM-2-2	1/8	1/8	7/16	0.88
68PM-5/32-1	5/32	1/16	3/8	0.95
68PM-5/32-2	5/32	1/8	7/16	0.74
68PM-5/32-4	5/32	1/4	9/16	0.99
68PM-3-1	3/16	1/16	7/16	0.95
68PM-3-2	3/16	1/8	7/16	0.92
68PM-3-4	3/16	1/4	9/16	1.10

68PMT Male Connector

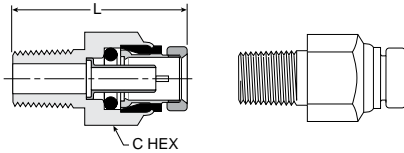

Part No.	Tube Size	Pipe Thread (NPTF)	C Hex	L
68PMT-4-2	1/4	1/8	1/2	1.06
68PMT-4-4	1/4	1/4	9/16	1.19
68PMT-4-6	1/4	3/8	3/4	1.27
68PMT-6-2	3/8	1/8	3/4	1.37
68PMT-6-4	3/8	1/4	3/4	1.43
68PMT-6-6	3/8	3/8	3/4	1.33
68PMT-6-8	3/8	1/2	7/8	1.38
68PMT-8-4	1/2	1/4	7/8	1.72
68PMT-8-6	1/2	3/8	7/8	1.52
68PMT-8-8	1/2	1/2	7/8	1.44
68PMT-10-6	5/8	3/8	1	1.88
68PMT-10-8	5/8	1/2	1	1.88
68PMT-12-8	3/4	1/2	1-3/16	2.03

169PMNS Male Elbow Non-Swivel 90°

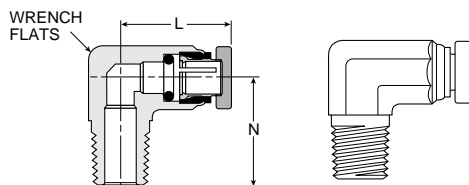

Part No.	Tube Size	Pipe Thread (NPTF)	Wrench Flats	L	N
169PMNS-2-2	1/8	1/8	3/8	0.86	0.68
169PMNS-5/32-2	5/32	1/8	3/8	0.88	0.68
169PMNS-3-2	3/16	1/8	3/8	0.75	0.67
169PMNS-3-4	3/16	1/4	1/2	0.74	0.93

169PMT Male Elbow Swivel 90°

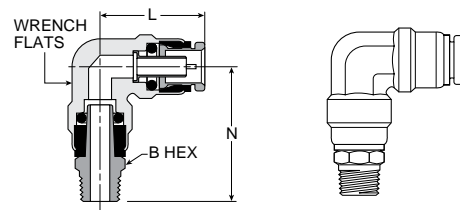

Part No.	Tube Size	Pipe Thread (NPTF)	Wrench Flats	B Hex	L	N
169PMT-4-2	1/4	1/8	13/32	7/16	0.84	1.21
169PMT-4-4	1/4	1/4	13/32	9/16	0.84	1.43
169PMT-4-6	1/4	3/8	13/32	11/16	0.84	1.43
169PMT-6-2	3/8	1/8	9/16	9/16	1.11	1.41
169PMT-6-4	3/8	1/4	9/16	9/16	1.11	1.58
169PMT-6-6	3/8	3/8	9/16	11/16	1.11	1.58
169PMT-6-8	3/8	1/2	9/16	7/8	1.11	1.79
169PMT-8-4	1/2	1/4	11/16	5/8	1.27	1.73
169PMT-8-6	1/2	3/8	11/16	3/4	1.27	1.81
169PMT-8-8	1/2	1/2	11/16	7/8	1.27	1.96
169PMT-10-6	5/8	3/8	7/8	3/4	1.53	2.03
169PMT-10-8	5/8	1/2	7/8	7/8	1.53	2.18

169PMTL Male Elbow Long Non-Swivel 90°

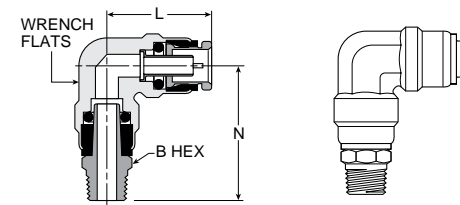

Part No.	Tube Size	Pipe Thread (NPTF)	Wrench Flats	B Hex	L	N
169PMTL-6-4	3/8	1/4	9/16	9/16	1.06	1.63
169PMTL-6-6	3/8	3/8	9/16	7/8	1.19	2.50
169PMTL-6-8	3/8	1/2	9/16	7/8	1.19	2.50
169PMTL-8-8	1/2	1/2	11/16	7/8	1.22	2.50
169PMTL-10-8	5/8	1/2	7/8	7/8	1.46	2.50



169PMTNS Male Elbow Non-Swivel 90°

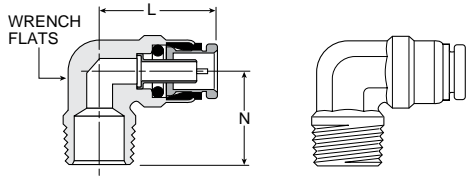

Part No.	Tube Size	Pipe		L	N
		Thread (NPTF)	Wrench Flats		
169PMTNS-4-2	1/4	1/8	1/2	0.84	0.72
169PMTNS-4-4	1/4	1/4	1/2	0.84	0.90
169PMTNS-4-6	1/4	3/8	1/2	0.84	1.06
169PMTNS-6-2	3/8	1/8	9/16	1.05	0.75
169PMTNS-6-4	3/8	1/4	9/16	1.05	0.94
169PMTNS-6-6	3/8	3/8	3/4	1.05	0.94
169PMTNS-6-8	3/8	1/2	11/16	1.12	1.26
169PMTNS-8-4	1/2	1/4	11/16	1.17	1.06
169PMTNS-8-6	1/2	3/8	11/16	1.22	1.06
169PMTNS-8-8	1/2	1/2	11/16	1.22	1.26
169PMTNS-10-6	5/8	3/8	7/8	1.46	1.11
169PMTNS-10-8	5/8	1/2	7/8	1.46	1.32
169PMTNS-12-8	3/4	1/2	1	1.81	1.44

171PMT Male Run Tee Swivel

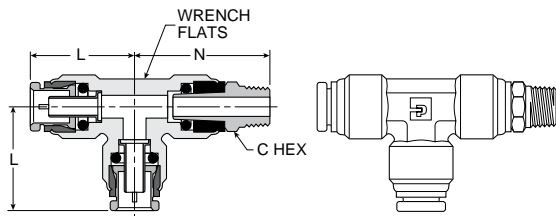

Part No.	Tube Size	Pipe		C Hex	L	N
		Thread (NPTF)	Wrench Flats			
171PMT-4-2	1/4	1/8	1/2	7/16	.85	1.25
171PMT-4-4	1/4	1/4	1/2	9/16	.85	1.48
171PMT-4-6	1/4	3/8	1/2	11/16	.85	1.43
171PMT-6-4	3/8	1/4	5/8	9/16	1.21	1.83
171PMT-6-6	3/8	3/8	5/8	11/16	1.21	1.83
171PMT-8-4	1/2	1/4	7/8	5/8	1.27	1.74
171PMT-8-6	1/2	3/8	7/8	3/4	1.27	1.83
171PMT-8-8	1/2	1/2	7/8	7/8	1.27	1.99

171PMTNS Male Run Tee Non-Swivel

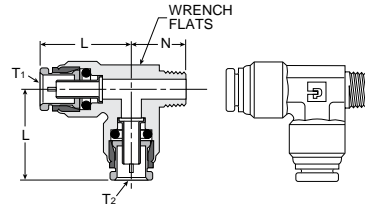

Part No.	Tube 1 Size	Tube 2 Size	Pipe Thread (NPTF)	Wrench Flats	L1	L2	N
171PMTNS-4-6-4	1/4	3/8	1/4	5/8	0.93	1.21	0.97
171PMTNS-6-4	3/8	3/8	1/4	5/8	1.21	1.21	0.97
171PMTNS-6-4-4	3/8	1/4	1/4	5/8	1.21	0.93	0.97
171PMTNS-6-4-6	3/8	1/4	3/8	5/8	1.22	0.97	0.93
171PMTNS-6-6	1/2	3/8	3/8	5/8	1.21	1.27	0.97
171PMTNS-6-8	1/2	3/8	1/2	5/8	1.17	1.27	1.26
171PMTNS-8-4	1/2	1/2	1/4	7/8	1.28	1.27	1.06

172PMT Male Branch Tee Swivel

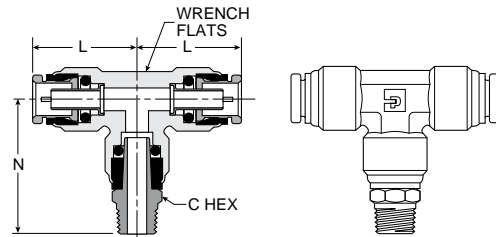

Part No.	Tube Size	Pipe Thread (NPTF)	Wrench Flats	C Hex	L	N
172PMT-4-4	1/4	1/4	1/2	9/16	0.85	1.43
172PMT-6-2	3/8	1/8	5/8	9/16	1.22	1.66
172PMT-6-4	3/8	1/4	5/8	5/8	1.22	1.83
172PMT-6-6	3/8	3/8	5/8	3/4	1.22	1.83
172PMT-8-4	1/2	1/4	7/8	5/8	1.27	1.73
172PMT-8-6	1/2	3/8	7/8	3/4	1.27	1.79
172PMT-8-8	1/2	1/2	7/8	7/8	1.27	1.97

172PMTNS Male Branch Tee Non-Swivel

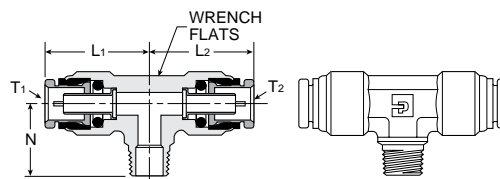

Part No.	Tube 1 Size	Tube 2 Size	Pipe Thread (NPTF)	Wrench Flats	L1	L2	N
172PMTNS-6-4	3/8	3/8	1/4	5/8	1.21	1.21	0.97
172PMTNS-6-4-4	3/8	1/4	1/4	5/8	1.21	.93	0.97
172PMTNS-6-6	3/8	3/8	3/8	5/8	1.21	1.21	0.97
172PMTNS-6-8	3/8	3/8	1/2	7/8	1.17	1.17	1.26
172PMTNS-8-6	1/2	1/2	3/8	7/8	1.28	1.28	1.06
172PMTNS-8-6-8	1/2	3/8	1/2	7/8	1.25	1.25	1.25
172PMTNS-8-8	1/2	1/2	1/2	7/8	1.34	1.25	1.25





Single & Double Operators – Solenoid

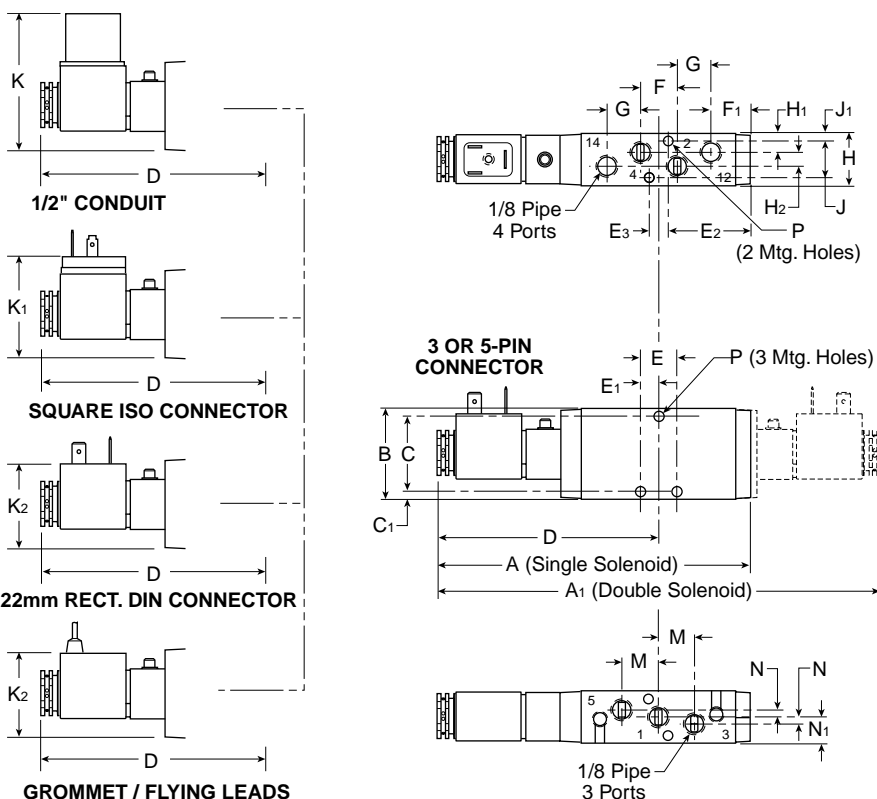

P2LAX (Solenoid)

A 5.31 (135)	A₁ 7.72 (196)	B 1.57 (40)	C 1.30 (33)
C₁ .14 (3.5)	D 3.86 (98)	E .63 (16)	E₁ .31 (8)
E₂ 1.42 (36)	E₃ .33 (8.5)	F .63 (16)	F₁ .67 (17)
G .59 (15)	H .87 (22)	H₁ .31 (8)	H₂ .24 (6)
J .63 (16)	J₁ .12 (3)	K 2.36 (60)	K₁ 1.61 (41)
K₂ 1.50 (38)	M .63 (16)	N .12 (3)	N₁ .43 (11)
P Ø .16 Ø (4.1)			

Inches (mm)

Single & Double Operators – Remote Pilot

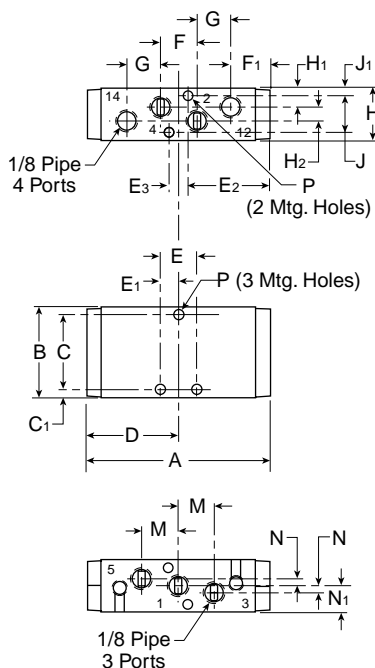

P2LAX (Remote)

A 3.19 (81)	B 1.57 (40)	C 1.30 (33)	C₁ .14 (3.5)
D 1.57 (40)	E 1.47 (16)	E₁ .31 (8)	E₂ 1.42 (36)
E₃ .33 (8.5)	F .63 (16)	F₁ .67 (17)	G .59 (15)
H .87 (22)	H₁ .31 (8)	H₂ .24 (6)	J .63 (16)
J₁ .12 (3)	M .63 (16)	N .12 (3)	N₁ .43 (11)
P Ø .16 Ø (4.1)			

Inches (mm)



Hand Lever Operated

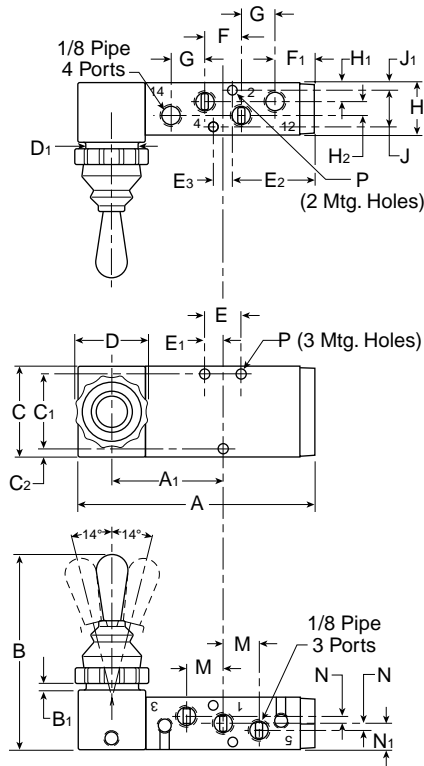

P2LAX Hand Lever

A 4.02 (102)	A₁ 1.89 (48)	B 3.23 (825)	B₁ .12 (3)
C 1.57 (40)	C₁ 1.30 (33)	C₂ .14 (3.5)	D 1.18 (30)
D₁ .89 (22.5)	E 1.47 (16)	E₁ .31 (8)	E₂ 1.42 (36)
E₃ .33 (8.5)	F .63 (16)	F₁ .67 (17)	G .59 (15)
H .87 (22)	H₁ .31 (8)	H₂ .24 (6)	J .63 (16)
J₁ .12 (3)	M .63 (16)	N .12 (3)	N₁ .43 (11)
P Ø .16 Ø (4.1)			

Inches (mm)

B

Single & Double Operators – IEM Aluminum Bar Manifold

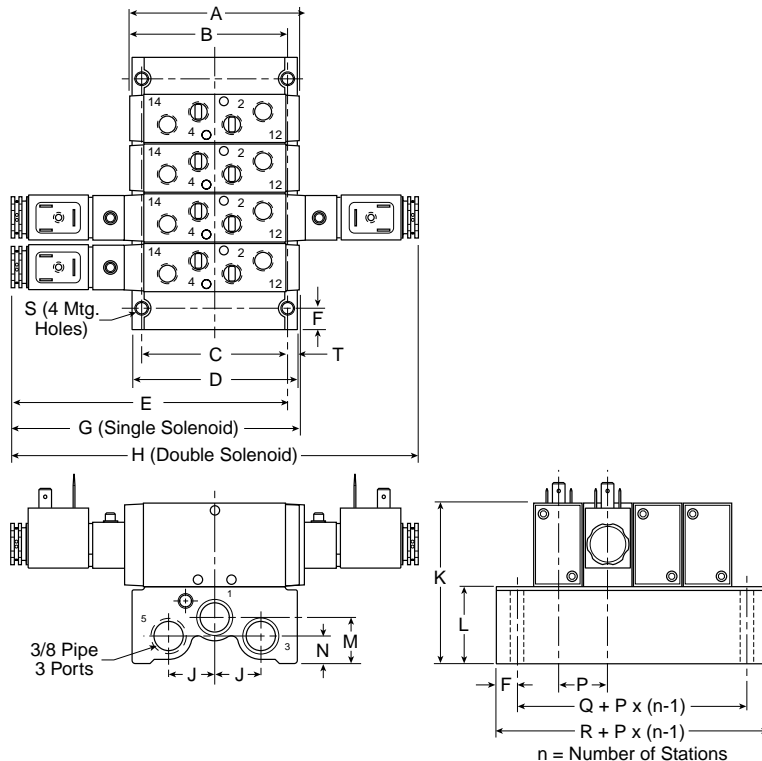

IEM Aluminum Bar Manifold

A 3.19 (81)	B 2.95 (75)	C 2.76 (70)	D 3.12 (79)
E 5.24 (133)	F .41 (10.5)	G 5.31 (135)	H 7.72 (196)
J .87 (22)	K 3.11 (79)	L 1.54 (39)	M .87 (22)
N .52 (13.2)	P .93 (23.5)	Q 1.56 (39.5)	R 2.36 (60)
S Ø .22 Ø (5.5)	T .18 (4.6)		

Inches (mm)



Single & Double Operators – Solenoid

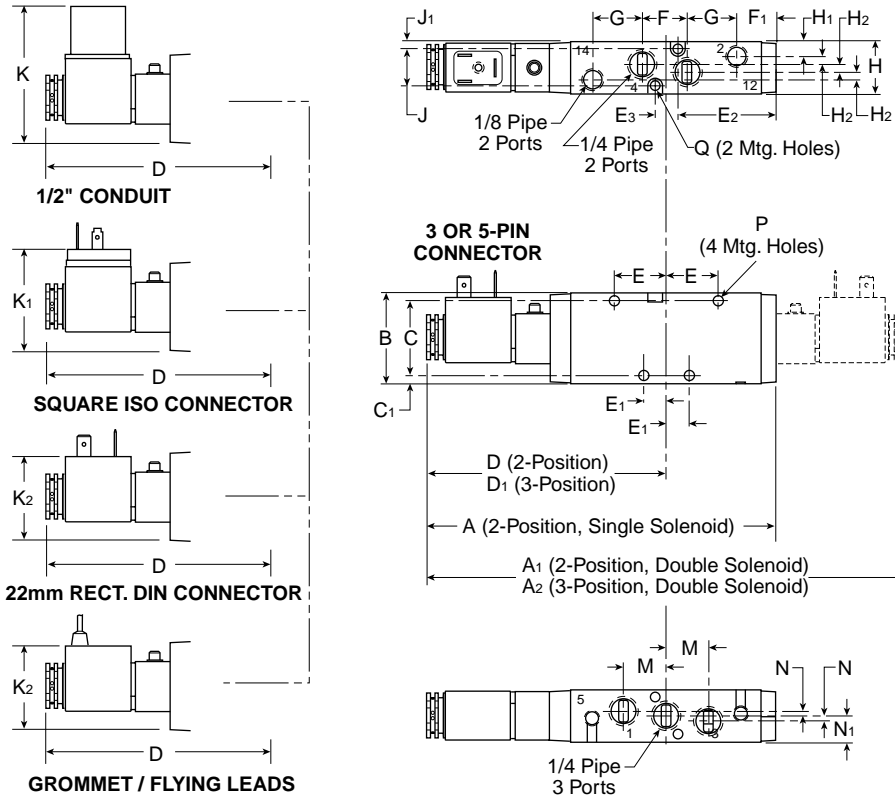

P2LBX (Solenoid)

A 6.14 (156)	A₁ 8.39 (213)	A₂ 9.06 (230)	B 1.57 (40)
C 1.26 (32)	C₁ .16 (4)	D 4.21 (107)	D₁ 4.55 (116)
E .91 (23)	E₁ .39 (10)	E₂ 1.73 (44)	E₃ .39 (10)
F .79 (20)	F₁ .67 (17)	G .87 (22)	H .87 (22)
H₁ .26 (6.6)	H₂ .12 (3)	J .65 (16.5)	J₁ .11 (2.8)
K 2.36 (60)	K₁ 1.61 (41)	K₂ 1.50 (38)	M .79 (20)
N .08 (2)	N₁ .43 (11)	P Ø .17 Ø (4.3)	Q Ø .12 Ø (3.1)

Inches (mm)

Single & Double Operators – Remote Pilot

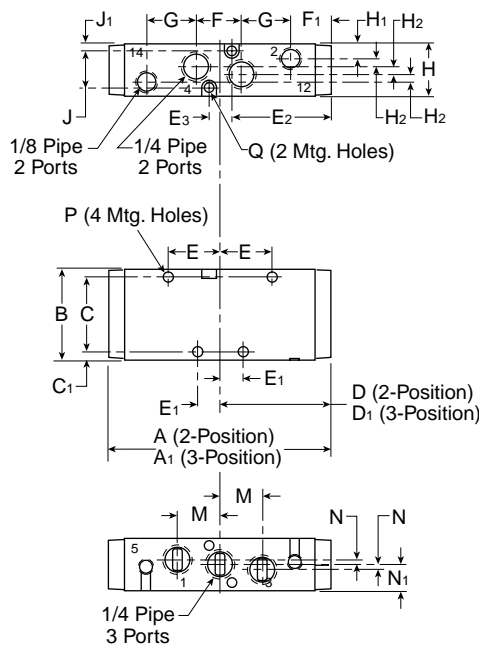

P2LBX (Remote)

A 3.95 (100)	A₁ 4.61 (117)	B 1.57 (40)	C 1.26 (32)
C₁ .16 (4)	D 1.93 (49)	D₁ 2.28 (58)	E .91 (23)
E₁ .39 (10)	E₂ 1.73 (44)	E₃ .39 (10)	F .79 (20)
F₁ .67 (17)	G .87 (22)	H .87 (22)	H₁ .26 (6.6)
H₂ .12 (3)	J .65 (16.5)	J₁ .11 (2.8)	K 2.90 (74)
M .79 (20)	N .08 (2)	N₁ .43 (11)	P Ø .17 Ø (4.3)
Q Ø .12 Ø (3.1)			

Inches (mm)

B



Single & Double Operators – IEM Aluminum Bar Manifold

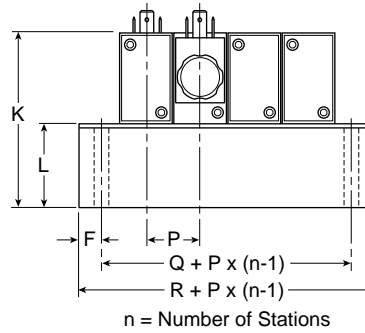
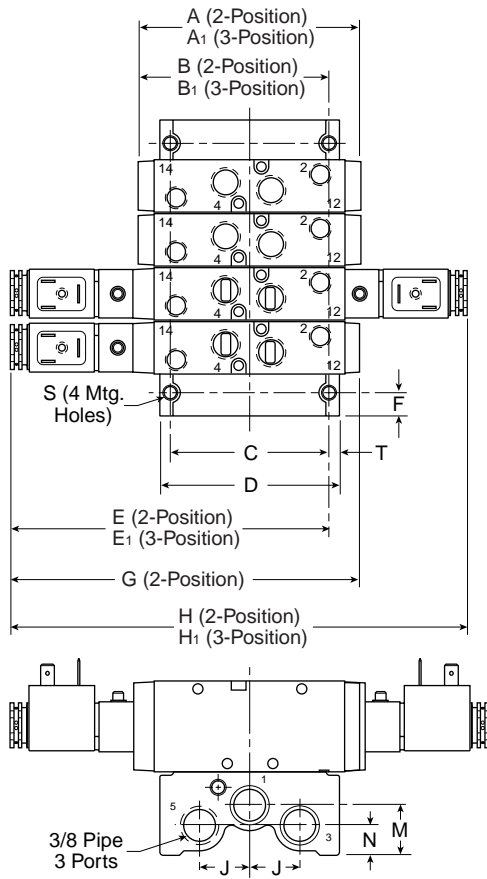

IEM Aluminum Bar Manifold

A 3.95 (100)	A₁ 4.61 (117)	B 3.42 (87)	B₁ 3.76 (96)
C 2.76 (70)	D 3.12 (79)	E 5.47 (139)	E₁ 5.81 (148)
F .40 (10.2)	G 6.10 (155)	H 8.39 (213)	H₁ 9.06 (230)
J .87 (22)	K 3.11 (79)	L 1.47 (37)	M .87 (22)
N .52 (13.2)	P .93 (23.5)	Q 1.56 (39.5)	R 2.36 (60)
S Ø .22 Ø (5.5)	T .18 (4.6)		

Inches (mm)

B



Single & Double Operators – Solenoid

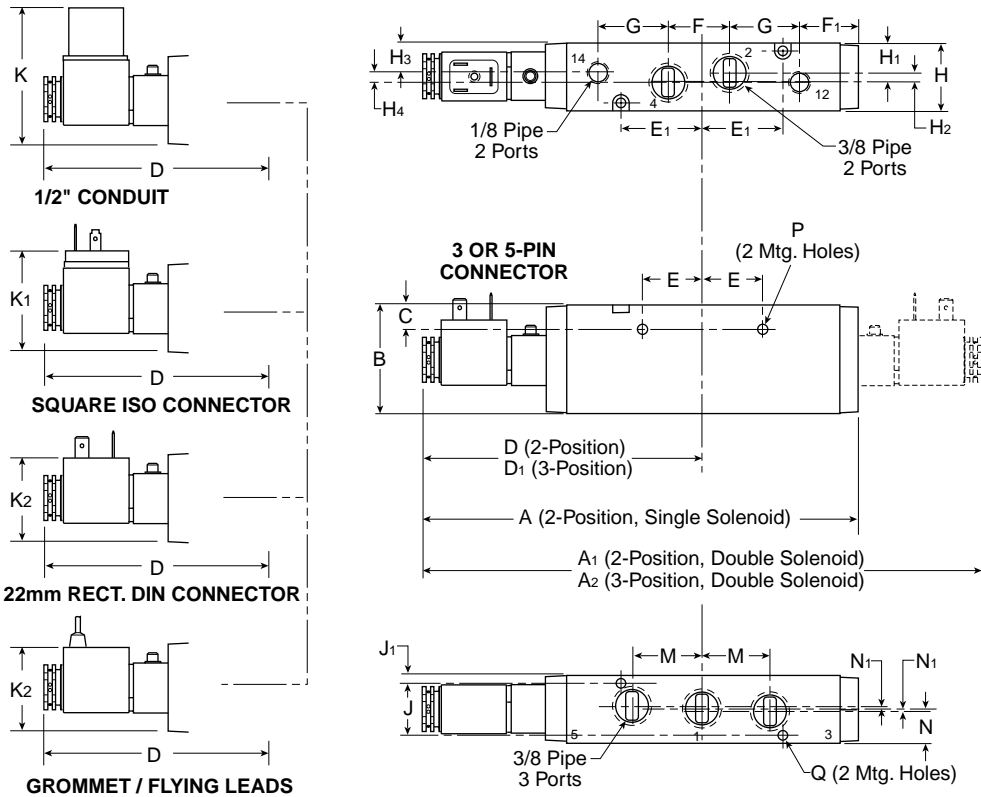

P2LCX (Solenoid)

A 7.64 (194)	A₁ 9.84 (250)	A₂ 10.71 (272)	B 1.89 (48)
C .44 (11.2)	D 4.92 (125)	D₁ 5.35 (136)	E 1.04 (26.5)
E₁ 1.39 (35.4)	F 1.06 (27)	F₁ 1.02 (26)	G 1.22 (31)
H 1.18 (30)	H₁ .53 (13.5)	H₂ .12 (3)	H₃ .51 (13)
H₄ .16 (4)	J .91 (23)	J₁ .14 (3.5)	K 2.52 (64)
K₁ 1.77 (45)	K₂ 1.65 (42)	M 1.18 (30)	N .59 (15)
N₁ .04 (1)	P ∅ .27 ∅ (6.9)	Q ∅ .17 ∅ (4.4)	

Inches (mm)

Single & Double Operators – Remote Pilot

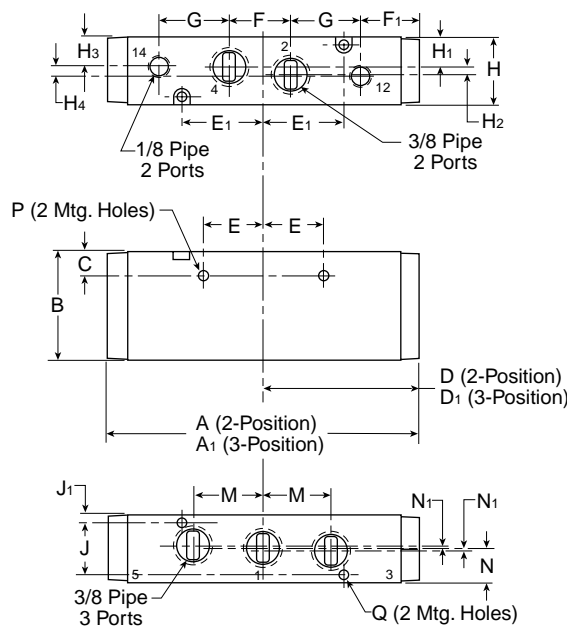

P2LCX (Remote)

A 5.51 (140)	A₁ 6.38 (162)	B 1.89 (48)	C .44 (11.2)
D 2.76 (70)	D₁ 3.18 (81)	E 1.04 (26.5)	E₁ 1.39 (35.4)
F 1.06 (27)	F₁ 1.02 (26)	G 1.22 (31)	H 1.18 (30)
H₁ .53 (13.5)	H₂ .12 (3)	H₃ .51 (13)	H₄ .16 (4)
J .91 (23)	J₁ .14 (3.5)	K 2.47 (62.8)	M 1.18 (30)
N .59 (15)	N₁ .04 (1)	P ∅ .27 ∅ (6.9)	Q ∅ .17 ∅ (4.4)

Inches (mm)

B



Single & Double Operators – IEM Aluminum Bar Manifold

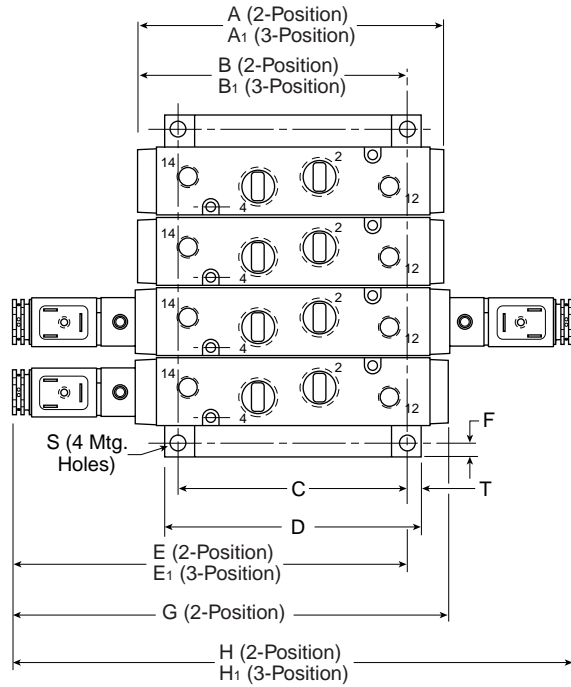

IEM Aluminum Bar Manifold

A	A₁	B	B₁
5.51 (140)	6.38 (162)	4.72 (120)	5.16 (131)
C	D	E	E₁
3.94 (100)	4.41 (112)	6.89 (170)	7.13 (181)
F	G	H	H₁
.24 (6)	7.68 (195)	9.84 (250)	10.71 (272)
J	K	L	P
1.26 (32)	3.43 (87)	1.54 (39)	1.24 (31.5)
Q	R	S	
1.77 (45)	2.24 (57)	∅ .26 ∅ (6.5)	

Inches (mm)

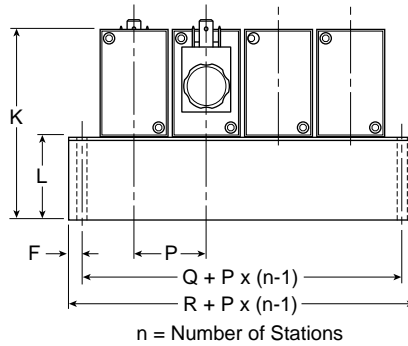
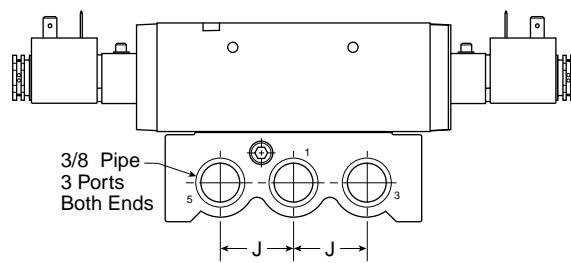

B



Single & Double Operators – Solenoid

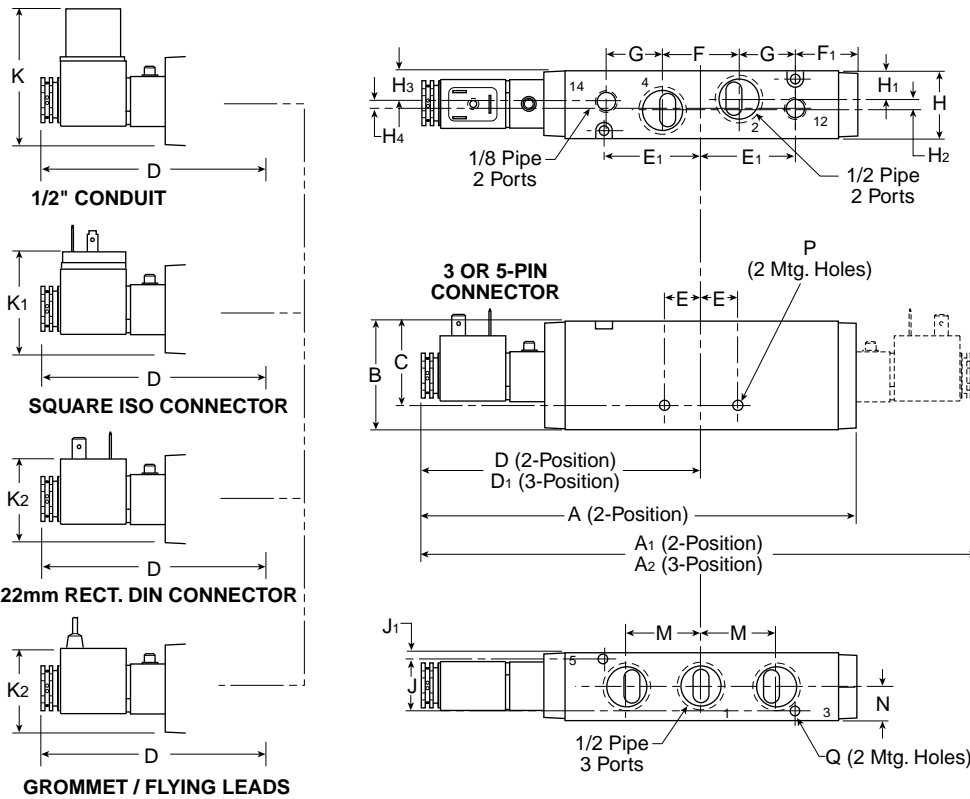

P2LDX (Solenoid)

A 7.64 (194)	A₁ 9.84 (250)	A₂ 10.70 (273)	B 1.89 (48)
C 1.59 (40.5)	D 4.92 (125)	D₁ 5.83 (148)	E .67 (17)
E₁ 1.65 (42)	F 1.34 (34)	F₁ 1.08 (27.5)	G .98 (25)
H 1.18 (30)	H₁ .49 (12.5)	H₂ .20 (5)	H₃ .51 (13)
H₄ .16 (4)	J .91 (23)	J₁ .14 (3.5)	K 2.52 (64)
K₁ 1.77 (45)	K₂ 1.65 (42)	M 1.29 (32.7)	N .59 (15)
P Ø .26 Ø (6.6)	Q Ø .17 Ø (4.4)		

Inches (mm)

Single & Double Operators – Remote Pilot

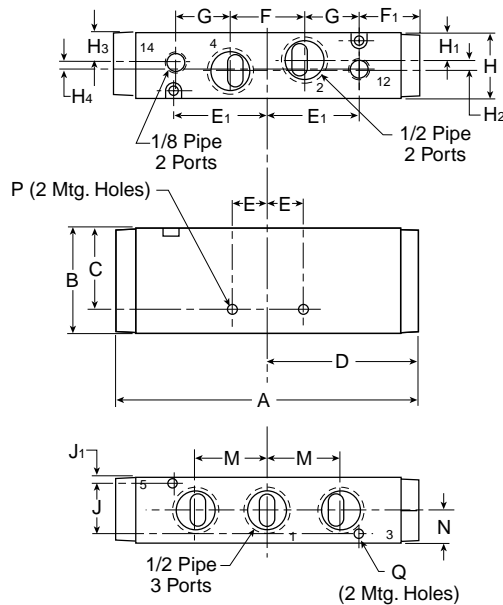

P2LDX (Remote)

A 5.47 (139)	B 1.89 (48)	C 1.59 (40.5)	D 2.63 (67)
E .67 (17)	E₁ 1.65 (42)	F 1.34 (34)	F₁ 1.08 (27.5)
G .98 (25)	H 1.18 (30)	H₁ .49 (12.5)	H₂ .20 (5)
H₃ .51 (13)	H₄ .16 (4)	J .91 (23)	J₁ .14 (3.5)
K 2.47 (62.8)	M 1.29 (32.7)	N .59 (15)	P Ø .26 Ø (6.6)
Q Ø .17 Ø (4.4)			

Inches (mm)

B



Directair 2 Series

Inline Valves

Manual / Mechanical

3 & 4-Way, 3 & 5-Port, 2-Position

Section C

www.parker.com/pneu/directair



Directair 2 Series Basic Features.....	C3
3-Way Poppet Valves.....	C4
3-Way Spool Valves.....	C5-C6
4-Way Spool Valves.....	C7-C8
Model Number Index.....	C9
Technical Information.....	C10
Dimensions	
Poppet Valves.....	C11-C12
Spool Valves.....	C13-C16

BOLD ITEMS ARE MOST POPULAR.

Standard text part numbers may have longer lead times.



C

Directair 2 Series

Specifications

Inline Valve

- 1/8" Port
- 4-Way, 2-Position
- 3-Way, 2-Position

Manual Operators

- Lever
- Toggle
- Button

Mechanical Operators

- Plunger
- Roller
- One-Way Tripper

Spool Style

Packed Bore Style – .20 Cv

- Stainless Steel Spool
- Fluorocarbon O-Rings
- 3-Way & 4-Way

Poppet Style – .17 Cv

- Economical
- 3-Way Normally Closed Function

Operating Pressure

- Vacuum to 150 PSI (28" Hg to 1035 kPa)
for spool style
- 0 to 150 PSI (0 to 1035 kPa)
for poppet style

Operating Temperature

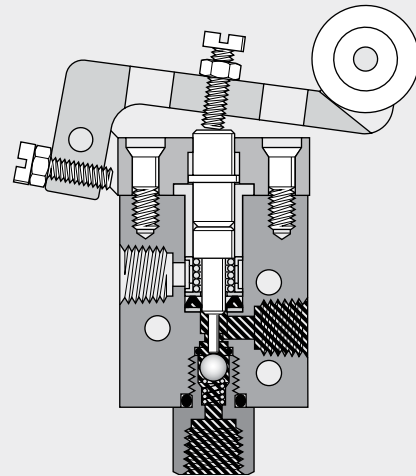

- 32°F to 175°F (0°C to 80°C)

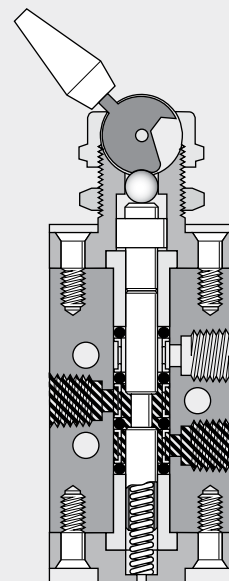

Roller Operated



Toggle Operated

 Pressure  Exhaust

C

Plunger Operated

40411 1000 Plunger Operated, Spring Return

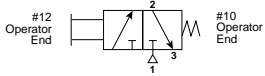

Spring Return

Normal Position – Pressure at Inlet Port 1 is blocked. Outlet Port 2 is connected to Exhaust Port 3.

Actuated Position – Pressure at Inlet Port 1 is connected to Outlet Port 2. Exhaust Port 3 is blocked.



Roller Operated

40421 1000 Roller Operated, Spring Return

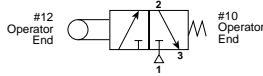

Spring Return

Normal Position – Pressure at Inlet Port 1 is blocked. Outlet Port 2 is connected to Exhaust Port 3.

Actuated Position – Pressure at Inlet Port 1 is connected to Outlet Port 2. Exhaust Port 3 is blocked.



C

Tripper Operated

40431 1000 One-Way Tripper Operated, Spring Return

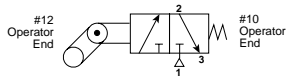

Spring Return

Normal Position – Pressure at Inlet Port 1 is blocked. Outlet Port 2 is connected to Exhaust Port 3.

Actuated Position – Pressure at Inlet Port 1 is connected to Outlet Port 2. Exhaust Port 3 is blocked.



Toggle Operated

40481 1000 Detented Toggle, Spring Return

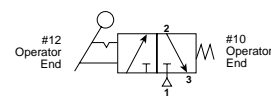

Spring Return

Normal Position – Pressure at Inlet Port 1 is blocked. Outlet Port 2 is connected to Exhaust Port 3.

Actuated (Detented) Position – Pressure at Inlet Port 1 is connected to Outlet Port 2. Exhaust Port 3 is blocked.



Button Operated

40441 1000 Button Operated, Spring Return

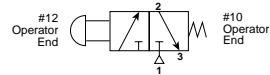

Spring Return

Normal Position – Pressure at Inlet Port 1 is blocked. Outlet Port 2 is connected to Exhaust Port 3.

Actuated Position – Pressure at Inlet Port 1 is connected to Outlet Port 2. Exhaust Port 3 is blocked.



Hand Lever Operated

40471 1000 Hand Lever Operated, Spring Return

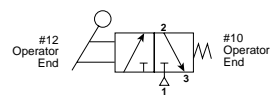

Spring Return

Normal Position – Pressure at Inlet Port 1 is blocked. Outlet Port 2 is connected to Exhaust Port 3.

Actuated Position – Pressure at Inlet Port 1 is connected to Outlet Port 2. Exhaust Port 3 is blocked.



Plunger Operated

- 41411 1000** Plunger Operated, Spring Return
- 41412 1000** Plunger Operated, Spring Return, Foot Mounted
- 41415 1000** Plunger Operated, Pilot Return

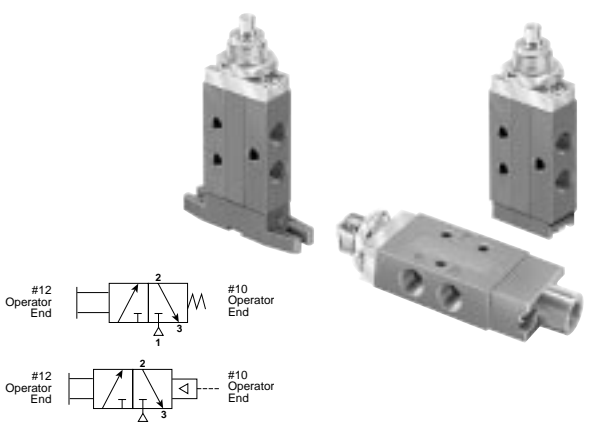

The image shows two views of a plunger operated spool valve: a side view and a top view. Below the images are two schematic diagrams. The top diagram shows a spring return valve with a spring symbol on the right side of the spool. The bottom diagram shows a pilot return valve with a dashed line and a triangle symbol on the right side of the spool. Both diagrams label the #12 Operator End on the left and the #10 Operator End on the right. The ports are numbered 1 (inlet), 2 (outlet), and 3 (exhaust).

Spring Return
Normal Position – Pressure at Inlet Port 1 is blocked. Outlet Port 2 is connected to Exhaust Port 3.
Actuated Position – Pressure at Inlet Port 1 is connected to Outlet Port 2 Exhaust Port 3 is blocked.

Roller Operated

- 41421 1000** Roller Operated, Spring Return
- 41422 1000** Roller Operated, Spring Return, Foot Mounted
- 41425 1000** Roller Operated, Pilot Return

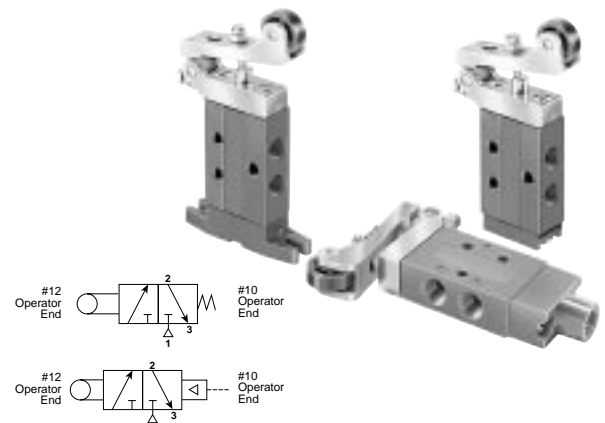

The image shows two views of a roller operated spool valve: a side view and a top view. Below the images are two schematic diagrams. The top diagram shows a spring return valve with a spring symbol on the right side of the spool. The bottom diagram shows a pilot return valve with a dashed line and a triangle symbol on the right side of the spool. Both diagrams label the #12 Operator End on the left and the #10 Operator End on the right. The ports are numbered 1 (inlet), 2 (outlet), and 3 (exhaust).

Spring Return
Normal Position – Pressure at Inlet Port 1 is blocked. Outlet Port 2 is connected to Exhaust Port 3.
Actuated Position – Pressure at Inlet Port 1 is connected to Outlet Port 2. Exhaust Port 3 is blocked.

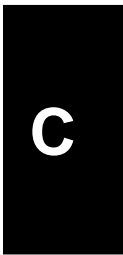

One-Way Tripper Operated

- 41431 1000** One-Way Tripper, Spring Return
- 41432 1000** One-Way Tripper, Spring Return, Foot Mounted
- 41435 1000** One-Way Tripper, Pilot Return

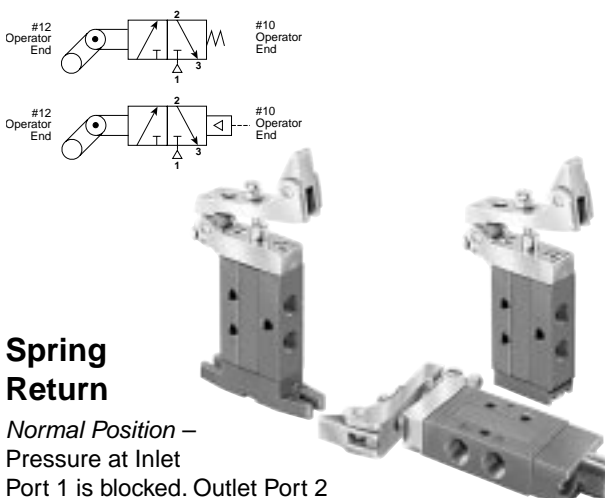

The image shows two views of a one-way tripper operated spool valve: a side view and a top view. Below the images are two schematic diagrams. The top diagram shows a spring return valve with a spring symbol on the right side of the spool. The bottom diagram shows a pilot return valve with a dashed line and a triangle symbol on the right side of the spool. Both diagrams label the #12 Operator End on the left and the #10 Operator End on the right. The ports are numbered 1 (inlet), 2 (outlet), and 3 (exhaust).

Spring Return
Normal Position – Pressure at Inlet Port 1 is blocked. Outlet Port 2 is connected to Exhaust Port 3.
Actuated Position – Pressure at Inlet Port 1 is connected to Outlet Port 2. Exhaust Port 3 is blocked.

Toggle Operated

- 41481 1000** Detented Toggle, Spring Return
- 41482 1000** Detented Toggle, Spring Return, Foot Mounted

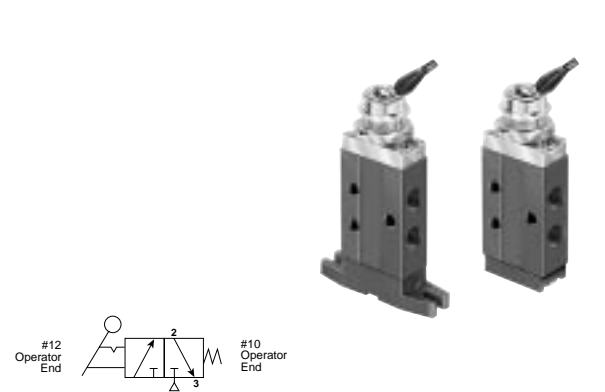

The image shows two views of a toggle operated spool valve: a side view and a top view. Below the images is a schematic diagram showing a spring return valve with a spring symbol on the right side of the spool. The diagram labels the #12 Operator End on the left and the #10 Operator End on the right. The ports are numbered 1 (inlet), 2 (outlet), and 3 (exhaust).

Spring Return
Normal Position – Pressure at Inlet Port 1 is blocked. Outlet Port 2 is connected to Exhaust Port 3.
Actuated (Detented) Position – Pressure at Inlet Port 1 is connected to Outlet Port 2. Exhaust Port 3 is blocked.

Button Operated

41441 1000 Button Operated, Spring Return

41442 1000 Button Operated, Spring Return, Foot Mounted

41445 1000 Button Operated, Pilot Return

#12 Operator End #10 Operator End

#12 Operator End #10 Operator End

Spring Return

Normal Position – Pressure at Inlet Port 1 is blocked. Outlet Port 2 is connected to Exhaust Port 3.

Actuated Position – Pressure at Inlet Port 1 is connected to Outlet Port 2. Exhaust Port 3 is blocked.

Button Operated

41493 1000 Button Operated, Manual Return

41494 1000 Button Operated, Manual Return, Foot Mounted

41495 1000 Button Operated, Manual Return or Pilot Return

#12 Operator End #10 Operator End

#12 Operator End #10 Operator End

Manual Return

Operator pulled last – Pressure at Inlet Port 1 is blocked. Outlet Port 2 is connected to Exhaust Port 3.

Operator pushed last – Pressure at Inlet Port 1 is connected to Outlet Port 2. Exhaust Port 3 is blocked.

Hand Lever Operated

41471 1000 Hand Lever Operated, Spring Return

41472 1000 Hand Lever Operated, Spring Return, Foot Mounted

41475 1000 Hand Lever Operated, Pilot Return

#12 Operator End #10 Operator End

#12 Operator End #10 Operator End

Spring Return

Normal Position – Pressure at Inlet Port 1 is blocked. Outlet Port 2 is connected to Exhaust Port 3.

Actuated Position – Pressure at Inlet Port 1 is connected to Outlet Port 2. Exhaust Port 3 is blocked.

C

Plunger Operated

- 41011 1000** Plunger Operated, Spring Return
- 41012 1000** Plunger Operated, Spring Return, Foot Mounted
- 41015 1000** Plunger Operated, Pilot Return

#14 Operator End #12 Operator End

#14 Operator End #12 Operator End

Spring Return

Normal Position – Pressure at Inlet Port 1 is connected to Outlet Port 2. Outlet Port 4 is connected to Exhaust Port 5.

Actuated Position – Pressure at Inlet Port 1 is connected to Outlet Port 4. Outlet Port 2 is connected to Exhaust Port 3.

Roller Operated

- 41021 1000** Roller Operated, Spring Return
- 41022 1000** Roller Operated, Spring Return, Foot Mounted
- 41025 1000** Roller Operated, Pilot Return

#14 Operator End #12 Operator End

#14 Operator End #12 Operator End

Spring Return

Normal Position – Pressure at Inlet Port 1 is connected to Outlet Port 2. Outlet Port 4 is connected to Exhaust Port 5.

Actuated Position – Pressure at Inlet Port 1 is connected to Outlet Port 4. Outlet Port 2 is connected to Exhaust Port 3.



One-Way Tripper Operated

- 41031 1000** One-Way Tripper, Spring Return
- 41032 1000** One-Way Tripper, Spring Return, Foot Mounted
- 41035 1000** One-Way Tripper, Pilot Return

#14 Operator End #12 Operator End

#14 Operator End #12 Operator End

Spring Return

Normal Position – Pressure at Inlet Port 1 is connected to Outlet Port 2. Outlet Port 4 is connected to Exhaust Port 5.

Actuated Position – Pressure at Inlet Port 1 is connected to Outlet Port 4. Outlet Port 2 is connected to Exhaust Port 3.

Toggle Operated

- 41081 1000** Detented Toggle, Spring Return
- 41082 1000** Detented Toggle, Spring Return, Foot Mounted

#14 Operator End #12 Operator End

#14 Operator End #12 Operator End

Spring Return

Normal Position – Pressure at Inlet Port 1 is connected to Outlet Port 2. Outlet Port 4 is connected to Exhaust Port 5.

Actuated (Detented) Position – Pressure at Inlet Port 1 is connected to Outlet Port 4. Outlet Port 2 is connected to Exhaust Port 3.

Button Operated

- 41041 1000** Button Operated, Spring Return
- 41042 1000** Button Operated, Spring Return, Foot Mounted
- 41045 1000** Button Operated, Pilot Return

Spring Return

Normal Position – Pressure at Inlet Port 1 is connected to Outlet Port 2. Outlet Port 4 is connected to Exhaust Port 5.

Actuated Position – Pressure at Inlet Port 1 is connected to Outlet Port 4. Outlet Port 2 is connected to Exhaust Port 3.

Button Operated

- 41093 1000** Button Operated, Manual Return
- 41094 1000** Button Operated, Manual Return, Foot Mounted
- 41095 1000** Button Operated, Manual Return or Pilot Return

Manual Return

Operator pulled last – Pressure at Inlet Port 1 is connected to Outlet Port 2. Outlet Port 4 is connected to Exhaust Port 5.

Operator pushed last – Pressure at Inlet Port 1 is connected to Outlet Port 4. Outlet Port 2 is connected to Exhaust Port 3.

Hand Lever Operated

- 41071 1000** Hand Lever Operated, Spring Return
- 41072 1000** Hand Lever Operated, Spring Return, Foot Mounted
- 41075 1000** Hand Lever Operated, Pilot Return

Spring Return

Normal Position – Pressure at Inlet Port 1 is connected to Outlet Port 2. Outlet Port 4 is connected to Exhaust Port 5.

Actuated Position – Pressure at Inlet Port 1 is connected to Outlet Port 4. Outlet Port 2 is connected to Exhaust Port 3.

C

Directair 2 Series

BOLD ITEMS ARE MOST POPULAR.

41 0 0 1 1 000

Basic Series	
1/8" Port Poppet Valve	40*
1/8" Port Spool Valve	41

* Only available in Spring Return.

Type	
4-Way, 2-Position Valve	0*
3-Way, 2-Position	4

* N/A with Basic Series 40.

Manual / Mechanical	
000	Standard

Mounting	
1	Direct Pipe Ported

Actuation	
Plunger	1
Roller - Delrin	2
One-Way Tripper	3
Button - Spring Return	4
Hand Lever	7
Toggle	8
Button - Push-Pull	9*

* N/A with Basic Series 40.

Return	
1†	Spring
2†	Spring w/ Foot Mount
3*	None (Manual Return)
4*	None (Manual Return w/ Foot Mount)
5†	Remote Pilot Return

* Available only with Actuation 9.

† N/A with Actuation 8.

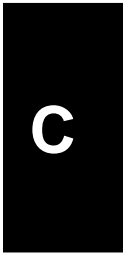

Operating Pressure

150 PSI (28" Hg to 1035 kPa)*

* Poppet valves cannot be used for vacuum.
 Minimum operating pressure = 0 PSIG.

Temperature Range

32°F to 175°F (0°C to 80°C)

⚠ CAUTION:
 If it is possible that the ambient temperature may fall below freezing, the medium must be moisture free to prevent internal damage or unpredictable behavior.

Materials

Body and Operator Housings.....Aluminum Extrusion
 Spool Stainless Steel
 Bushings Brass
 Spacers Zinc Die Cast
 Dynamic O-Rings.....Fluorocarbon
 Operator O-Rings.....Buna (Nitrile)
 Operator U-Cups.....Buna (Nitrile)
 Poppet Ball.....Nylon

Lubrication

For maximum service life use clean, lubricated air.
 Valves are shipped pre-lubricated and can be operated without additional lubrication with reduced service life.

Suggested Lubricant

F442 Oil

Flow Rating (Cv)

Flow Path	Direct Pipe Spool, 1/8" Ports	Direct Pipe Poppet, 1/8" Ports
1 → 2	.199	.125
1 → 4	.191	—
2 → 3	.192	.215
4 → 5	.212	—
Avg.	.199	N/A

Service Kits

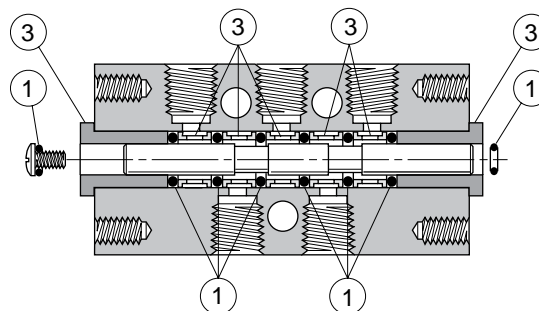

4-Way Spool

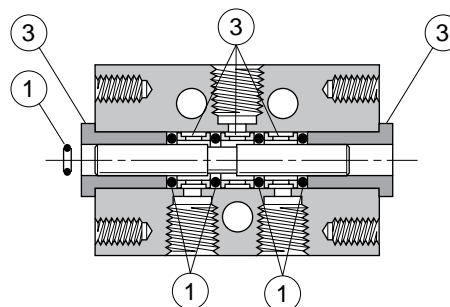

3-Way Spool

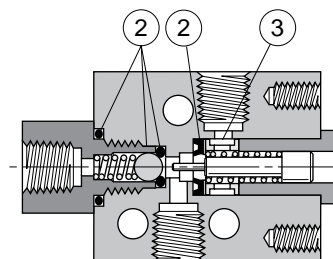

3-Way Poppet

- ① Spool Valve Seal Kit
 (3 & 4-Way, Direct Pipe Ported) **41000 8000**
- ② Poppet Valve Seal Kit **40411 8000**
- ③ Body Service Kit..... **41000 8005**

Plunger, Roller, One-Way Tripper & Toggle Operated

3-Way, 3-Port, 2-Position – 1/8" Ports

Plunger Operated

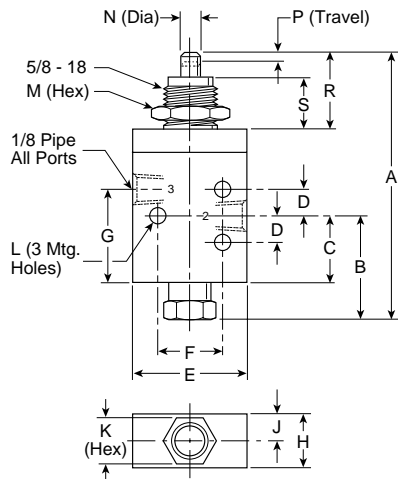

Roller Operated

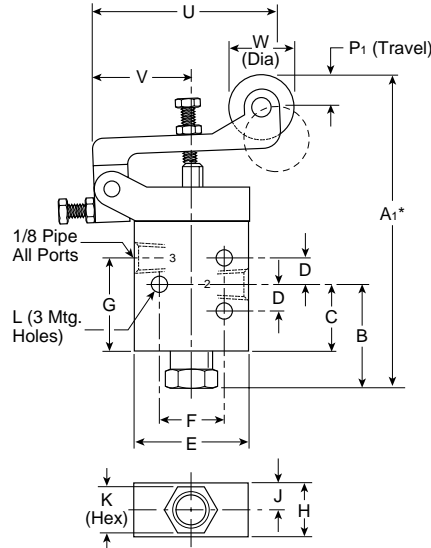

3-Way, 3-Port, 2-Position

A 3.37 (86)	A1* 4.21 (107)	A2* 4.46 (113)	A3 3.99 (101)	B 1.03 (26)
C .55 (14)	D .31 (8)	E 1.31 (33)	F .75 (19)	G .90 (23)
H .62 (16)	J .31 (8)	K .56 (14)	L .19 (5)	M .88 (22)
N .25 (6)	P .17 (4)	P1 .38 (10)	R .91 (23)	R1 1.53 (39)
S .62 (16)	S1 .78 (20)	U 2.28 (58)	V 1.19 (30)	W .75 (19)
X .19 (5)	Y 2.19 (56)			

* Dimensions may be reduced .44" using adjusting screw.

Inches (mm)

One-Way Tripper Operated

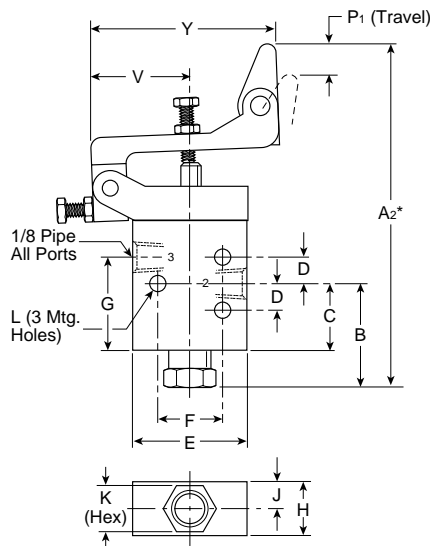

Toggle Operated

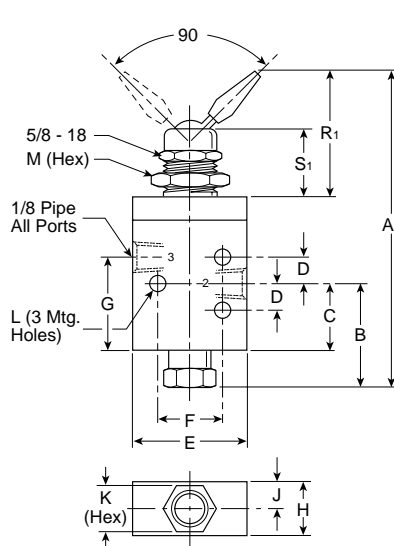

Button & Hand Lever Operated

3-Way, 3-Port, 2-Position – 1/8" Ports

Button Operated

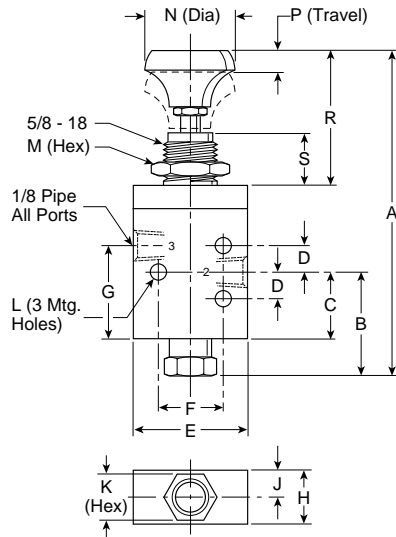

3-Way, 3-Port, 2-Position

A 4.13 (105)	A₁ 3.34 (85)	B 1.03 (26)	C .55 (14)	D .31 (8)
E 1.31 (33)	F .75 (19)	G .90 (23)	H .62 (16)	J .31 (8)
K .56 (14)	L .19 (5)	M .88 (22)	N 1.06 (27)	P .17 (4)
R 1.67 (42)	S .63 (16)	T 1.19 (30)	U .53 (13)	V 3.38 (86)

Inches (mm)

Hand Lever Operated

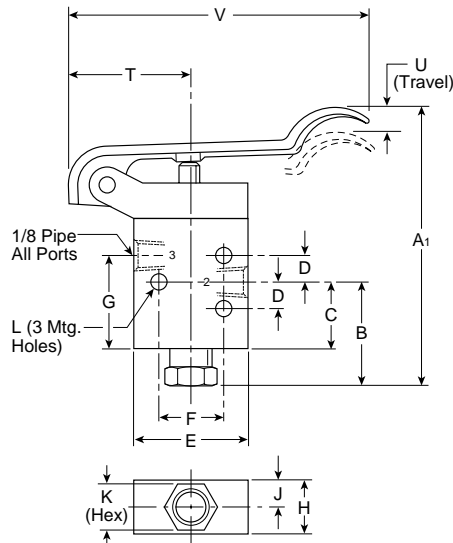

C

Plunger, Roller, One-Way Tripper & Toggle Operated

3-Way, 3-Port, 2-Position – 1/8" Ports

Plunger Operated

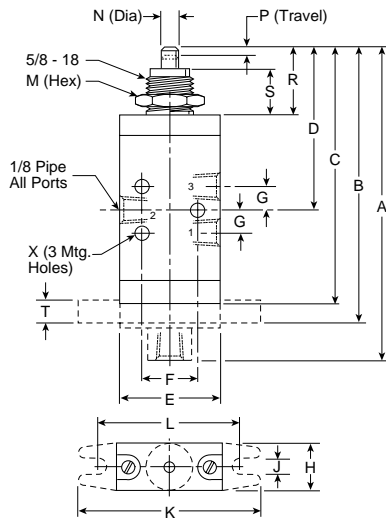

Roller Operated

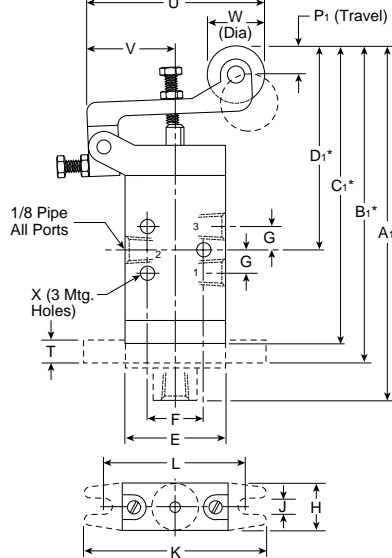

3-Way, 3-Port, 2-Position

A 4.14 (105)	A1* 4.98 (126)	A2* 5.23 (133)	A3 4.23 (107)	B 3.61 (92)
B1 4.45 (113)	B2 4.70 (119)	B3 4.00 (102)	C 3.38 (86)	C1 4.22 (107)
C2 4.47 (113)	C3 2.75 (70)	D 2.05 (52)	D1 2.98 (76)	D2 3.22 (82)
E 1.31 (33)	F .75 (19)	G .31 (8)	H .62 (16)	J .20 (5)
K 2.38 (60)	L 1.88 (48)	M .88 (22)	N .25 (6)	P .17 (4)
P1 .38 (10)	R .91 (23)	R1 1.53 (39)	S .62 (16)	S1 .78 (20)
T .25 (6)	U 2.28 (58)	V 1.19 (30)	W .75 (19)	X .19 (5)
Y 2.19 (56)				

* Dimensions may be reduced .44" using adjusting screw.

Inches (mm)

One-Way Tripper Operated

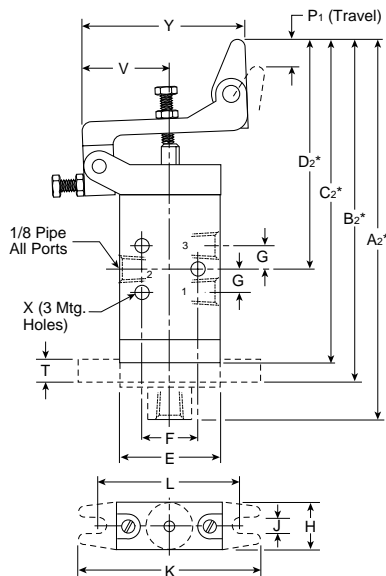

Toggle Operated

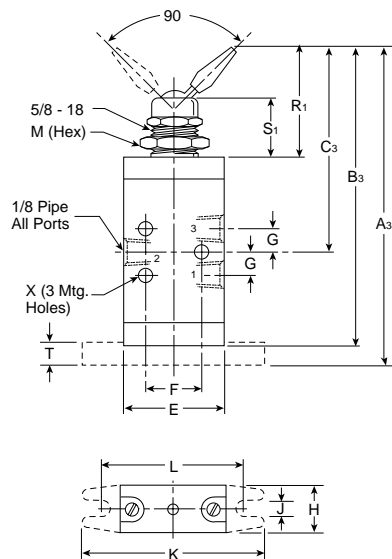

Button, Hand Lever Operated

3-Way, 3-Port, 2-Position – 1/8" Ports

Button Operated

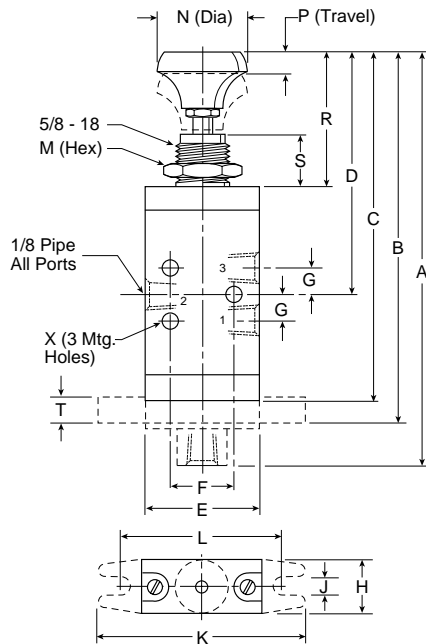

Hand Lever Operated

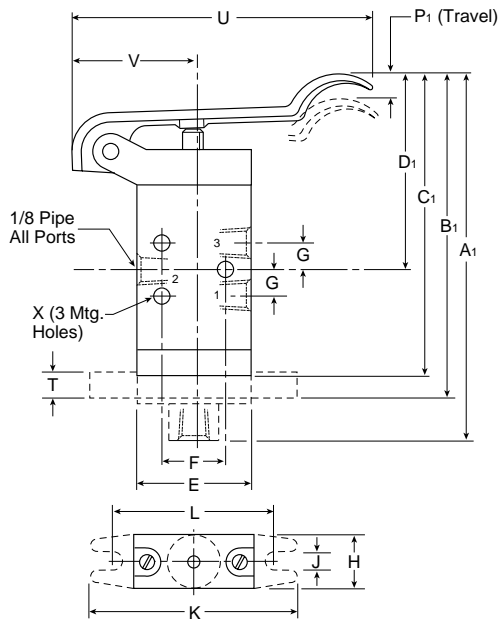

3-Way, 3-Port, 2-Position

A 5.08 (129)	A₁ 4.29 (109)	B 4.55 (115)	B₁ 3.77 (96)	C 4.31 (109)
C₁ 3.53 (90)	D 3.08 (78)	D₁ 2.29 (58)	E 1.31 (33)	F .75 (19)
G .31 (8)	H .62 (16)	J .20 (5)	K 2.38 (60)	L 1.88 (48)
M .88 (22)	N 1.06 (27)	P .17 (4)	P₁ .53 (13)	R 1.67 (42)
S .63 (16)	T .25 (6)	U 3.38 (86)	V 1.19 (30)	X .19 (5)
Y .59 (15)				

Inches (mm)

C

Plunger, Roller, One-Way Tripper & Toggle Operated

4-Way, 5-Port, 2-Position – 1/8" Ports

Plunger Operated

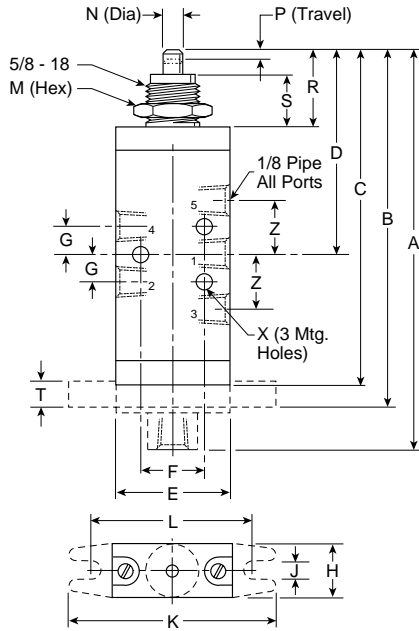

Roller Operated

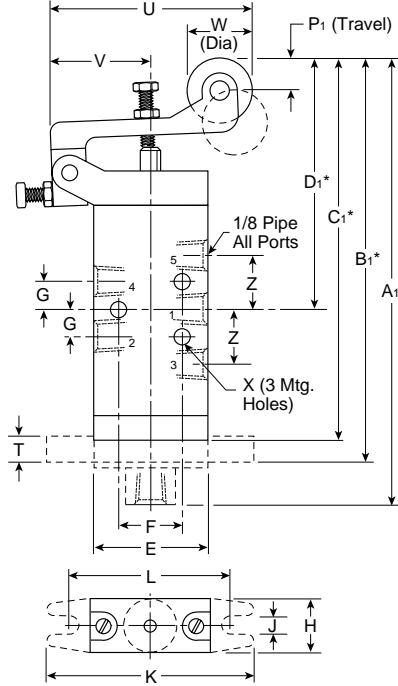

4-Way, 5-Port, 2-Position

A 4.75 (121)	A1* 5.59 (142)	A2* 5.84 (148)	A3 4.84 (123)	B 4.22 (107)
B1* 5.06 (128)	B2* 5.31 (135)	B3 4.61 (117)	C 3.99 (102)	C1* 4.83 (123)
C2* 5.08 (129)	C3 3.06 (78)	D 2.44 (62)	D1* 3.28 (83)	D2* 3.53 (90)
E 1.31 (33)	F .75 (19)	G .31 (8)	H .62 (16)	J .20 (5)
K 2.38 (60)	L 1.88 (48)	M .88 (22)	N .25 (6)	P .17 (4)
P1 .38 (10)	R .91 (23)	R1 1.53 (39)	S .62 (16)	S1 .78 (20)
T .25 (6)	U 2.28 (58)	V 1.19 (30)	W .75 (19)	X .19 (5)
Y 2.19 (56)	Z .62 (16)			

* Dimensions may be reduced .44" using adjusting screw.

Inches (mm)

One-Way Tripper Operated

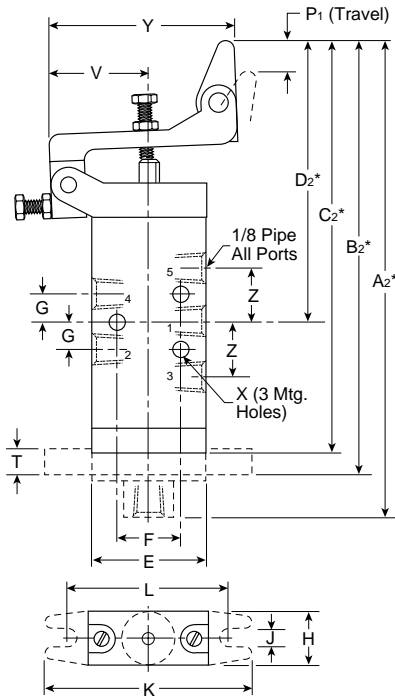

Toggle Operated

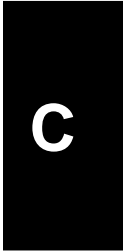
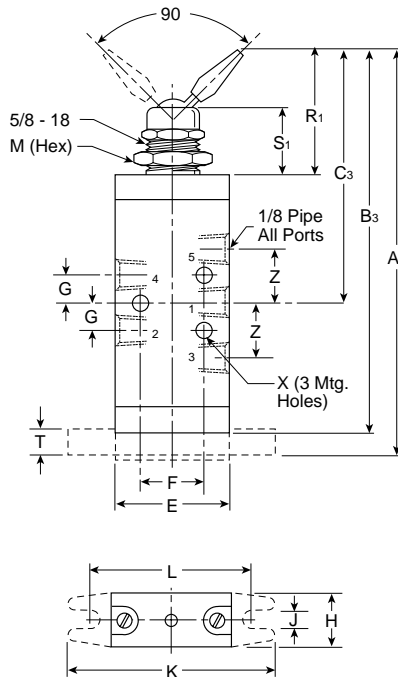

Button & Hand Lever Operated

4-Way, 5-Port, 2-Position – 1/8" Ports

Button Operated

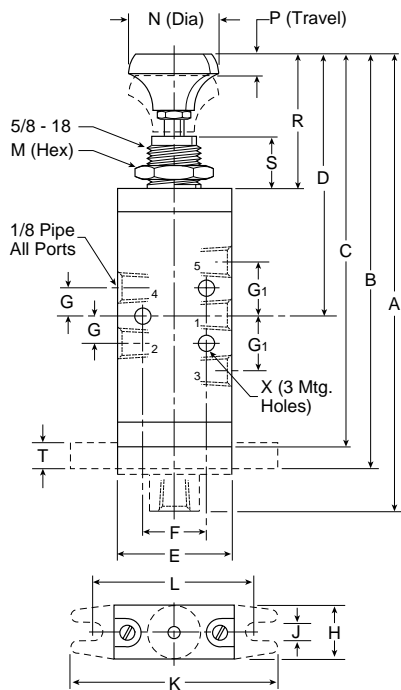

Hand Lever Operated

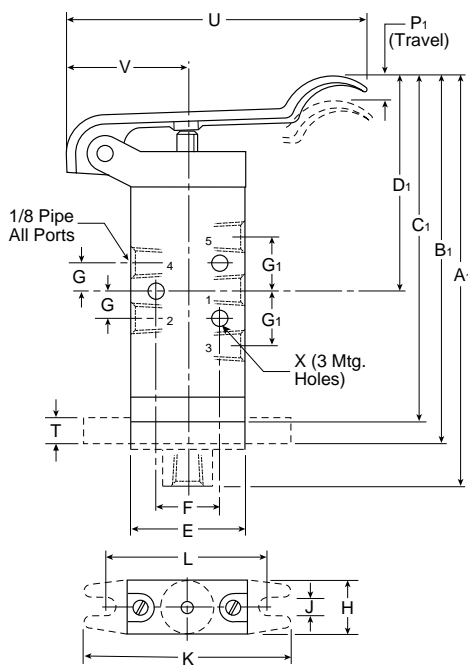

4-Way, 5-Port, 2-Position

A 5.69 (144)	A₁ 4.90 (124)	B 5.16 (131)	B₁ 4.38 (111)	C 4.92 (125)
C₁ 4.14 (105)	D 3.67 (93)	D₁ 2.90 (74)	E 1.31 (33)	F .75 (19)
G .31 (8)	G₁ .63 (16)	H .62 (16)	J .20 (5)	K 2.38 (60)
L 1.88 (48)	M .88 (22)	N 1.06 (27)	P .17 (4)	P₁ .53 (13)
R 1.67 (42)	S .63 (16)	T .25 (6)	U 3.38 (86)	V 1.19 (30)
X .19 (5)	Y .59 (15)			

Inches (mm)

C



Directair 4 Series

Inline Valves

Manual / Mechanical

3 & 4-Way, 3 & 5-Port,

2 & 3-Position

Section D

www.parker.com/pneu/directair



D

Directair 4 Series Basic Features.....	D3
3-Way Spool Valves.....	D4-D5
4-Way Spool Valves.....	D6-D7
Model Number Index.....	D8
Accessories & Service Kits.....	D9
Technical Information.....	D10
Dimensions	
3-Way – Button, Roller & Treadle.....	D11
3-Way – Lever & Pedal.....	D12
4-Way – Button, Roller, Pedal & Treadle.....	D13
4-Way – Lever.....	D14

BOLD ITEMS ARE MOST POPULAR.

Standard text part numbers may have longer lead times.



D

Directair 4 Series

Specifications

Inline Valve

- 1/4" Port
- 4-Way, 2 & 3-Position
- 3-Way, 2 & 3-Position

Manual Operators

- Lever
- Pedal
- Treadle
- Button

Mechanical Operators

- Roller

Packed Bore Style - .83 Cv

- Stainless Steel Spool
- Fluorocarbon O-rings

Operating Pressure

- Vacuum to 150 PSI
(28" Hg to 1035 kPa)

Operating Temperature

- 32 to 175°F (0 to 80°C)



Button Operated



Lever Operated



Treadle Operated

D

Button Operated

- 52441 1000** Button Operated, Spring Return
52445 1000 Button Operated, Pilot Return

Spring Return
Normal Position – Pressure at Inlet Port 1 is blocked. Outlet Port 2 is connected to Exhaust Port 3.
Actuated Position – Pressure at Inlet Port 1 is connected to Outlet Port 2. Exhaust Port 3 is blocked.

Button Operated

- 52443 1000** Button Operated, Manual Return

Manual Return
Operator pulled last – Pressure at Inlet Port 1 is blocked. Outlet Port 2 is connected to Exhaust Port 3.
Operator pushed last – Pressure at Inlet Port 1 is connected to Outlet Port 2. Exhaust Port 3 is blocked.

D

Treadle Operated

- 52493 1000** Treadle Operated

Treadle
Toe pressed last – Pressure at Inlet Port 1 is blocked. Outlet Port 2 is connected to Exhaust Port 3.
Heel pressed last – Pressure at Inlet Port 1 is connected to Outlet Port 2. Exhaust Port 3 is blocked.

CAUTION:
 This valve shall not be used to actuate a punch press. Do not use this valve on punch presses or press brakes. See OSHA 1910.217.
 See Accessories page for Pedal Guard Kit.

Roller Operated

- 52421 1000** Delrin Roller Operated, Spring Return
52425 1000 Delrin Roller Operated, Pilot Return
524A1 1000 Steel Roller Operated, Spring Return
524A5 1000 Steel Roller Operated, Pilot Return

Roller
Normal Position – Pressure at Inlet Port 1 is blocked. Outlet Port 2 is connected to Exhaust Port 3.
Actuated Position – Pressure at Inlet Port 1 is connected to Outlet Port 2. Exhaust Port 3 is blocked.

Lever Operated

52481 1000 Lever Operated, Spring Return



Spring Return

Normal Position – Pressure at Inlet Port 1 is blocked. Outlet Port 2 is connected to Exhaust Port 3.

Actuated Position – Pressure at Inlet Port 1 is connected to Outlet Port 2. Exhaust Port 3 is blocked.

Lever Operated

52483 1000 Lever Operated, Manual Return



Manual Return

Operator pushed last (toward body) – Pressure at Inlet Port 1 is blocked. Outlet Port 2 is connected to Exhaust Port 3.

Operator pulled last (away from body) – Pressure at Inlet Port 1 is connected to Outlet Port 2. Exhaust Port 3 is blocked.

Lever Operated – 3-Position

52383 1000 Lever Operated, 3-Position Detented, All Ports Blocked

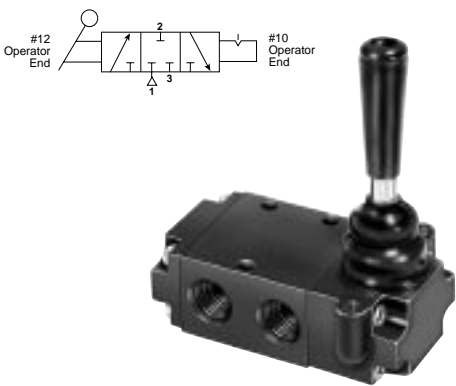

Lever

Operator pushed last (toward body) – Pressure at Inlet Port 1 is blocked. Outlet Port 2 is connected to Exhaust Port 3.

Operator pulled last (away from body) – Pressure at Inlet Port 1 is connected to Outlet Port 2. Exhaust Port 3 is blocked.

Center Position – All Ports blocked.

Pedal Operated

52471 1000 Pedal Operated, Spring Return
52475 1000 Pedal Operated, Pilot Return

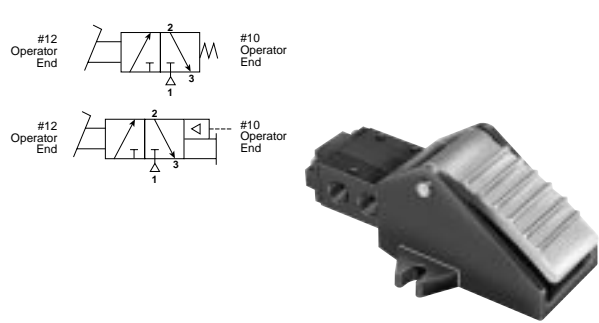

Pedal

Normal Position – Pressure at Inlet Port 1 is blocked. Outlet Port 2 is connected to Exhaust Port 3.

Actuated Position – Pressure at Inlet Port 1 is connected to Outlet Port 2. Exhaust Port 3 is blocked.

CAUTION:
 This valve shall not be used to actuate a punch press. Do not use this valve on punch presses or press brakes. See OSHA 1910.217.
 See Accessories page for Pedal Guard Kit.



Button Operated

- 52041 1000** Button Operated, Spring Return
52045 1000 Button Operated, Pilot Return

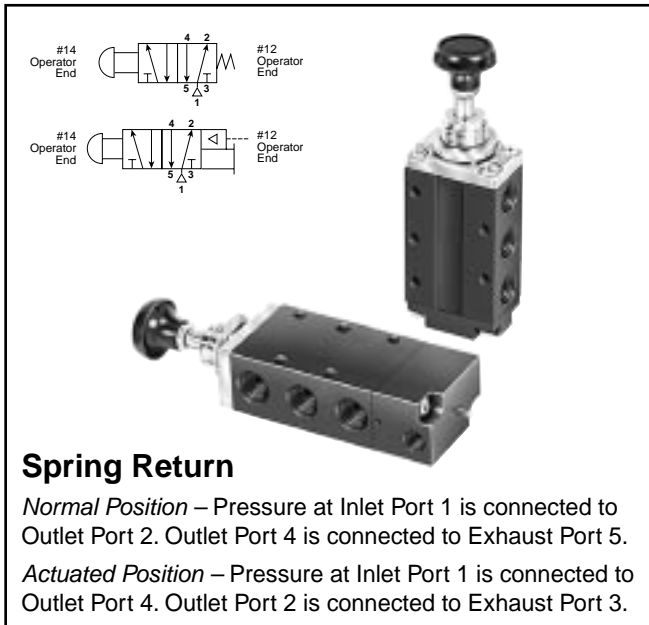

Button Operated

- 52043 1000** Button Operated, Manual Return

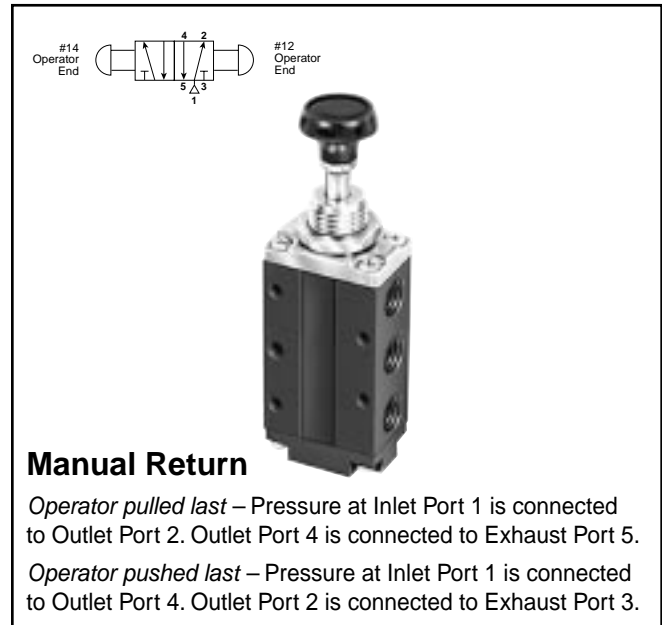

D

Pedal & Treadle Operated

- 52071 1000** Pedal Operated, Spring Return
52075 1000 Pedal Operated, Pilot Return
52093 1000 Treadle Operated

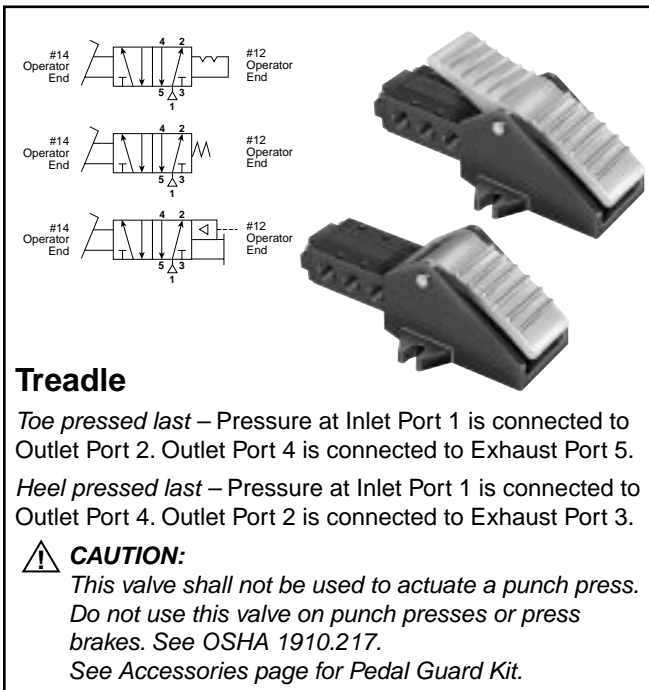

Roller Operated

- 52021 1000** Delrin Roller Operated, Spring Return
52025 1000 Delrin Roller Operated, Pilot Return
520A1 1000 Steel Roller Operated, Spring Return
520A5 1000 Steel Roller Operated, Pilot Return

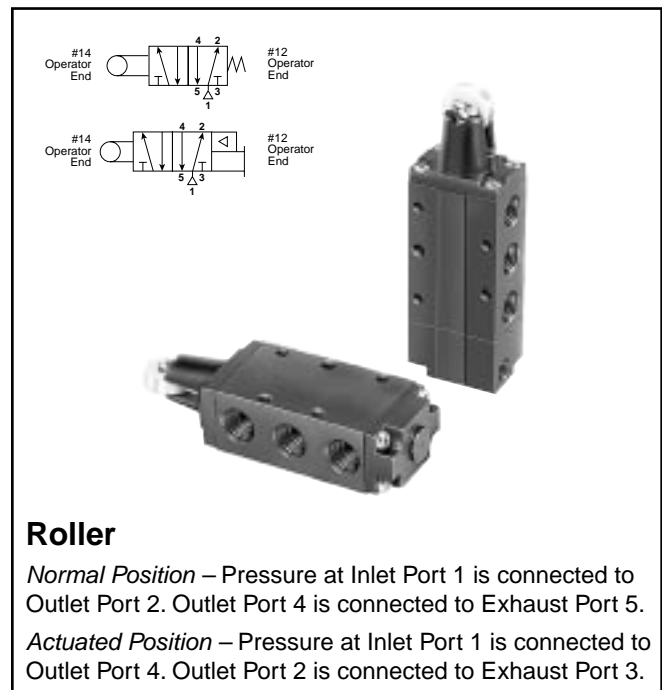

Lever Operated

52081 1000 Lever Operated, Spring Return

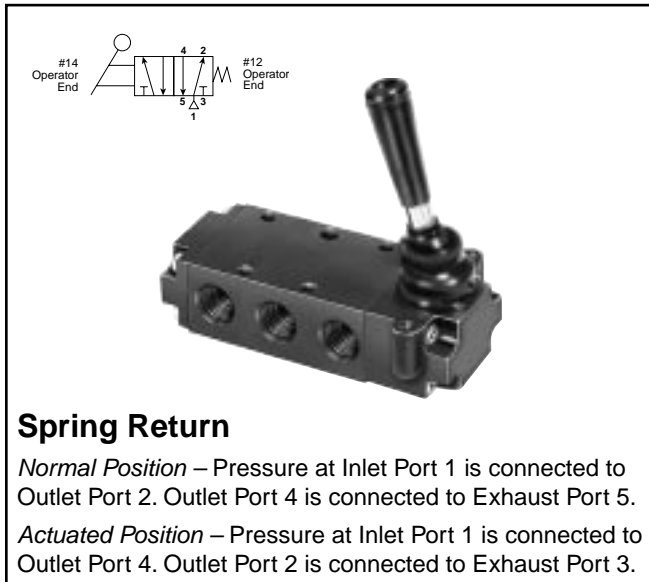

Spring Return

Normal Position – Pressure at Inlet Port 1 is connected to Outlet Port 2. Outlet Port 4 is connected to Exhaust Port 5.

Actuated Position – Pressure at Inlet Port 1 is connected to Outlet Port 4. Outlet Port 2 is connected to Exhaust Port 3.

Lever Operated

52083 1000 Lever Operated, Manual Return

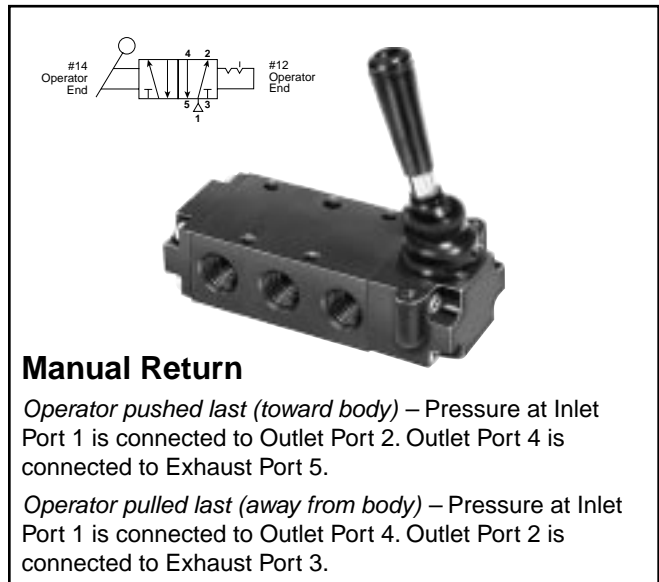

Manual Return

Operator pushed last (toward body) – Pressure at Inlet Port 1 is connected to Outlet Port 2. Outlet Port 4 is connected to Exhaust Port 5.

Operator pulled last (away from body) – Pressure at Inlet Port 1 is connected to Outlet Port 4. Outlet Port 2 is connected to Exhaust Port 3.

**Lever Operated, 3-Position
 Lever, Spring Centered**

52181 1000 Type 1, Closed Center

52281 1000 Type 2, Pressure Center

52981 1000 Type 9, Exhaust Center

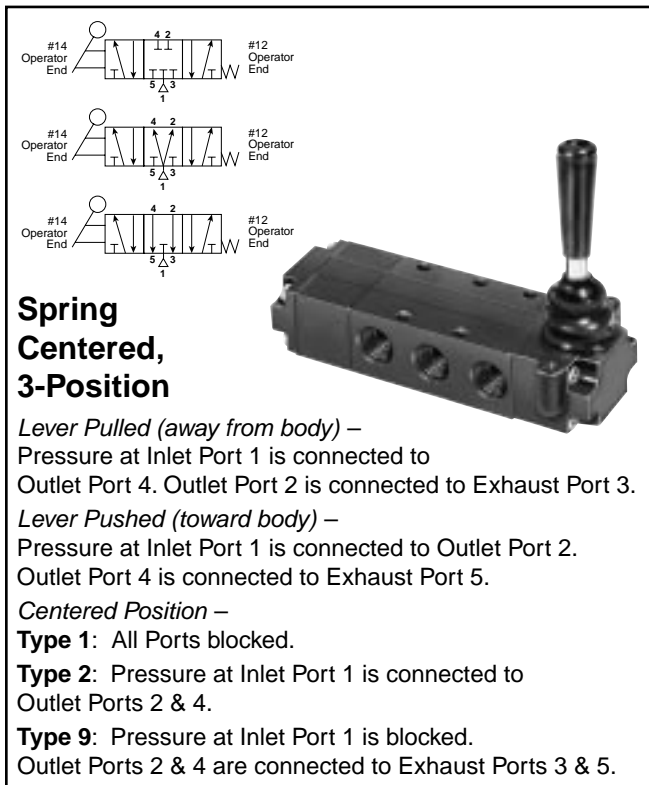

Spring Centered, 3-Position

Lever Pulled (away from body) – Pressure at Inlet Port 1 is connected to Outlet Port 4. Outlet Port 2 is connected to Exhaust Port 3.

Lever Pushed (toward body) – Pressure at Inlet Port 1 is connected to Outlet Port 2. Outlet Port 4 is connected to Exhaust Port 5.

Centered Position –

Type 1: All Ports blocked.

Type 2: Pressure at Inlet Port 1 is connected to Outlet Ports 2 & 4.

Type 9: Pressure at Inlet Port 1 is blocked. Outlet Ports 2 & 4 are connected to Exhaust Ports 3 & 5.

**Lever Operated, 3-Position
 Lever, Detented**

52183 1000 Type 1, Closed Center

52283 1000 Type 2, Pressure Center

52983 1000 Type 9, Exhaust Center

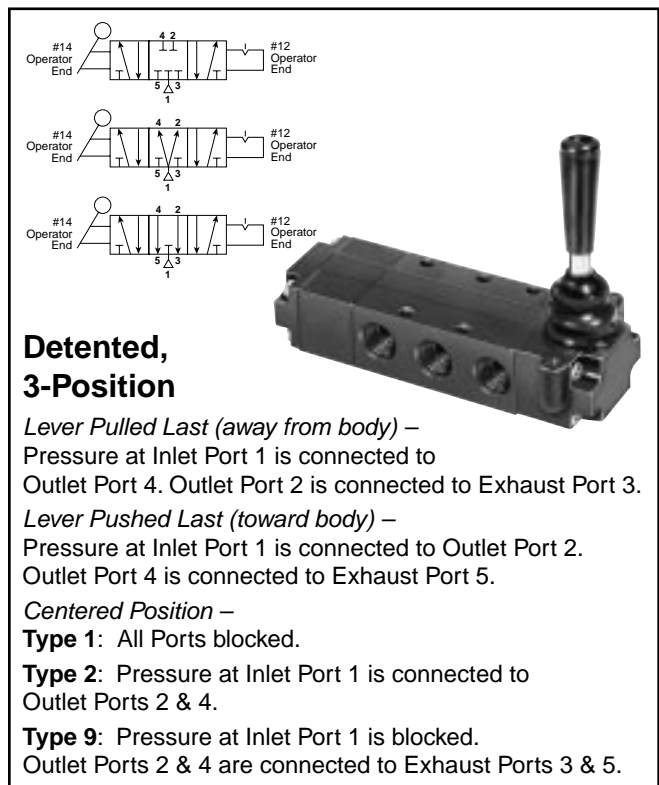

Detented, 3-Position

Lever Pulled Last (away from body) – Pressure at Inlet Port 1 is connected to Outlet Port 4. Outlet Port 2 is connected to Exhaust Port 3.

Lever Pushed Last (toward body) – Pressure at Inlet Port 1 is connected to Outlet Port 2. Outlet Port 4 is connected to Exhaust Port 5.

Centered Position –

Type 1: All Ports blocked.

Type 2: Pressure at Inlet Port 1 is connected to Outlet Ports 2 & 4.

Type 9: Pressure at Inlet Port 1 is blocked. Outlet Ports 2 & 4 are connected to Exhaust Ports 3 & 5.



Directair 4 Series

BOLD ITEMS ARE MOST POPULAR.

52 0 8 1 1 000

Basic Series	
1/4" Port Spool Valve	52

Manual / Mechanical	
000	Standard

Type	
4-Way, 2-Position Valve	0
4-Way, 3-Position, Closed Center	1*
4-Way, 3-Position, Pressure Center	2*
3-Way, 3-Position, Closed Center	3*
3-Way, 2-Position, Normally Closed	4
3-Way, 2-Position, Normally Open	6
4-Way, 3-Position, Exhaust Center	9*

* Only Available with Actuation 8 Lever.

Mounting	
0*	Base Mounted Valve Less Base
1	Direct Pipe Ported
3*	Subbase Mounted

* N/A with Actuation 7 or 9.
 * N/A with Type 3, 4 or 6.

Return	
1†	Spring
3†	None (Manual Return)
5*	Remote Pilot Return

* N/A with Actuation 8 & 9.
 † N/A with Actuation 2, 7 or A.
 * N/A with Actuation 9.

Actuation	
Roller - Delrin	2
Button	4
Pedal	7
Lever	8
Treadle	9
Roller - Metal	A



**Pedal Guard Kit
 No. 52071 8001**

Pedal guard meets safety requirements for foot operated valves by protecting pedal from accidental tripping from all angles. Guard is constructed of lightweight aluminum casting for strength and durability. Bolts quickly into place with only three screws without special valve mounting. One model fits any pedal (not treadle) operated "Directair 4" Series valve.

⚠ CAUTION:
*This valve shall not be used to actuate a punch press.
 Do not use this valve on punch presses or press brakes.
 See OSHA 1910.217.*

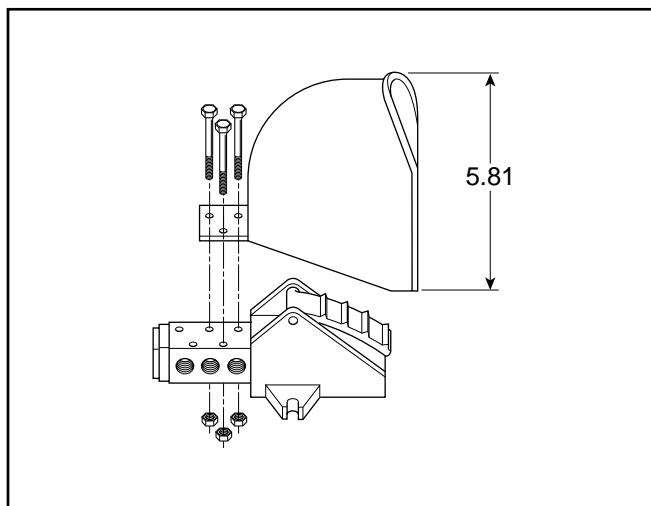

**Panel Mounting Kit
 No. 52083 8004**

Available for panel mounting direct pipe ported, lever operated "Directair 4" Series valves only. Kit includes a flange and two screws.

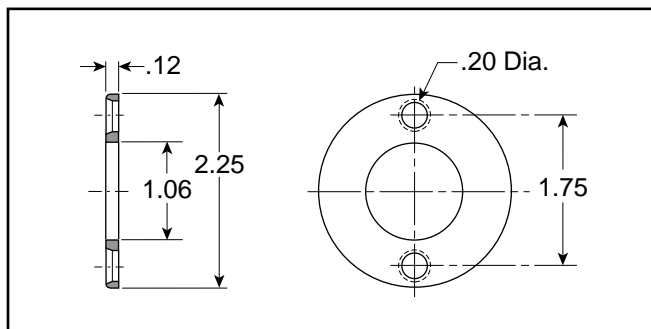

Service Kits

- Valve Seal Kit **52000 8050**
 (Contains all soft seals found in 3 & 4-Way bodies and all actuator styles.)
 All Fluorocarbon **52000 8500**

- Body Service Kit **52001 8005**
 (Contains bushing, springs, retainers and shell from 2 & 3-Position, 3 & 4-Way bodies.)

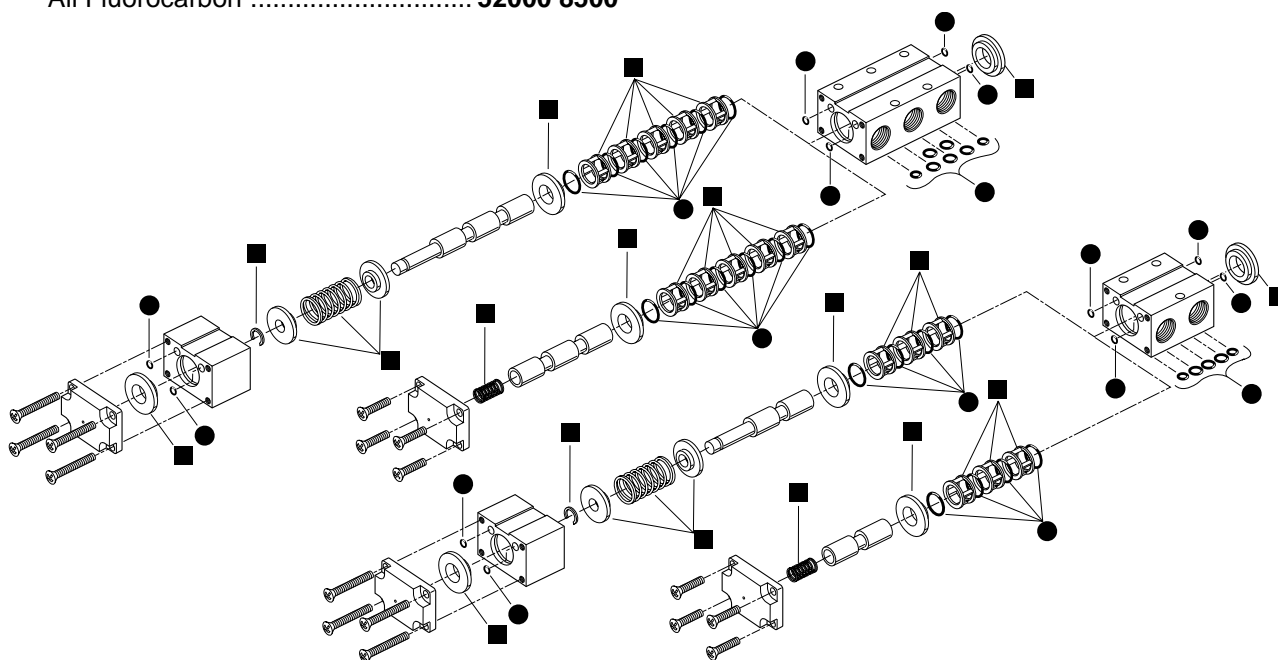

Operating Pressure

Vacuum to 150 PSI (28" Hg to 1035 kPa)

Temperature Range

32°F to 175°F (0°C to 80°C)

⚠ CAUTION:

If it is possible that the ambient temperature may fall below freezing, the medium must be moisture free to prevent internal damage or unpredictable behavior.

Materials

Body and Operator Housings.....Aluminum Extrusion
 SpoolStainless Steel
 Bushings and Pilot PistonBrass
 Dynamic SealsFluorocarbon
 U-CupsBuna (Nitrile)
 SpacersAluminum

Lubrication

For maximum service life use clean, lubricated air.
 Valves are shipped pre-lubricated and can be operated without additional lubrication with reduced service life.

Suggested Lubricant

F442 Oil

Flow Rating (Cv)

Flow Path	Direct Pipe Ported 1/4" Ports	Subbase Mounted 1/4" Side Ports
1 → 2	.82	.64
1 → 4	.84	.66
2 → 3	.84	.63
4 → 5	.83	.63
Avg.	.83	.64

Mechanically Operated Actuating Forces in Lbs.

	2-Position Spring Return	2-Position Manual Return	3-Position Spring Return	3-Position Manual Return
Button Actuator	13.0	2.0	13.0	N/A
Roller Actuator	13.0	N/A	N/A	N/A
Lever Actuator	4.0	2.0	4.0	2.5

Notes: N/A = Not Applicable
 All valves are at 100 PSIG inlet pressure to the valve.

D

Button, Roller & Treadle Operated

3-Way, 3-Port, 2-Position

Button Operated

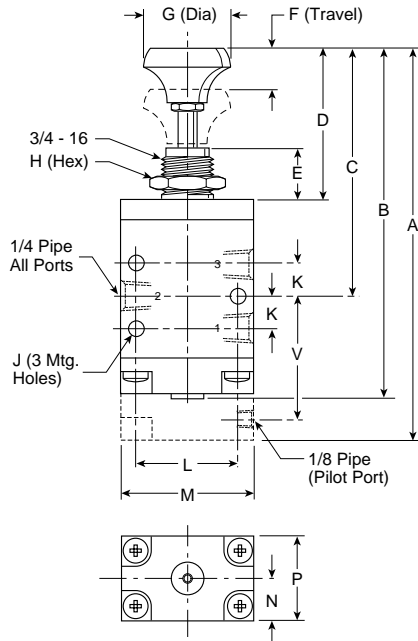

Roller Operated

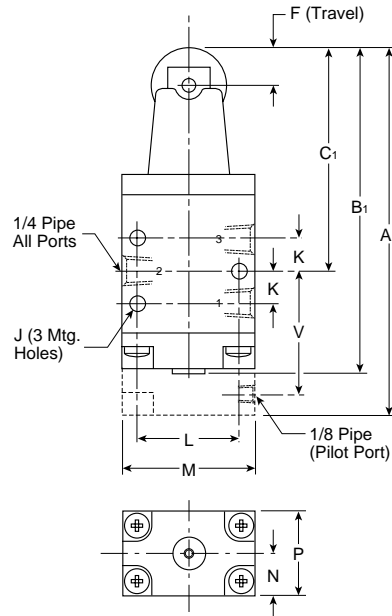

3-Way, 3-Port, 2-Position

A 4.91 (125)	A₁ 4.25 (108)	A₂ 6.55 (166)	B 4.44 (113)	B₁ 3.78 (96)
B₂ 5.20 (132)	C 3.10 (79)	C₁ 2.44 (62)	C₂ 2.19 (56)	D 2.00 (51)
E .63 (16)	F .32 (8)	G 1.05 (27)	H 1.00 (25)	J .19 (5)
K .41 (10)	L 1.25 (32)	M 1.63 (42)	N .53 (14)	P 1.06 (27)
Q .37 (10)	R 2.40 (61)	S .34 (9)	T 3.50 (89)	U 3.00 (76)
V 1.52 (39)				

Inches (mm)

Treadle Operated

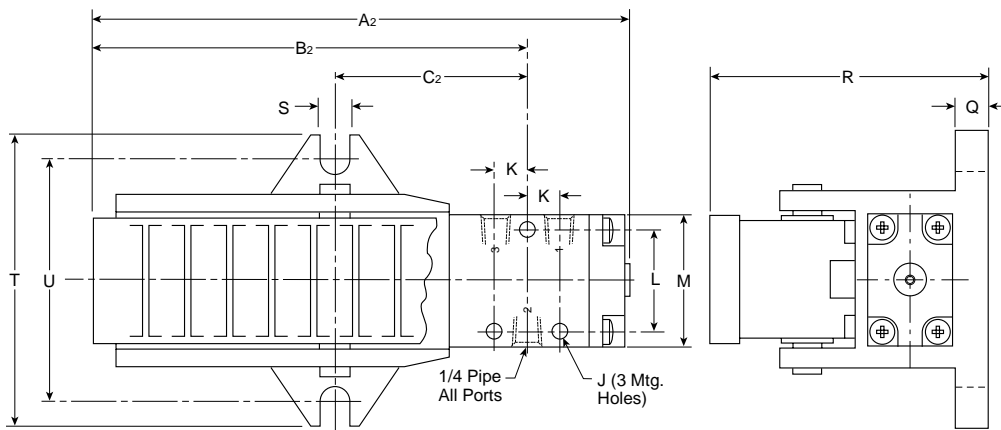

CAUTION:

*This valve shall not be used to actuate a punch press.
Do not use this valve on punch presses or press
brakes. See OSHA 1910.217.
See Accessories page for Pedal Guard Kit.*

Lever & Pedal Operated

3-Way, 3-Port, 2 & 3-Position

**Lever Operated
2-Position**

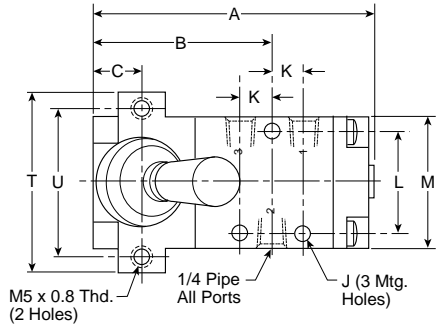

**Lever Operated
3-Position**

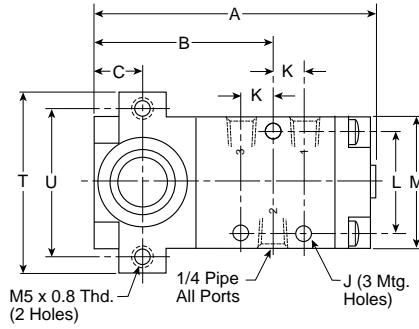

**3-Way, 3-Port,
2 & 3-Position**

A 3.31 (84)	A₁ 6.55 (166)	B 1.97 (50)	B₁ 5.20 (132)	C .53 (14)
C₁ 2.19 (56)	D 1.12 (28)	E 4.06 (103)	F 3.90 (99)	J .19 (5)
K .41 (10)	L 1.25 (32)	M 1.63 (42)	N .53 (14)	P 1.06 (27)
Q .37 (10)	R 2.40 (61)	S .34 (9)	T 2.13 (54)	T₁ 3.50 (89)
U 1.75 (44)	U₁ 44 (76)			

Inches (mm)

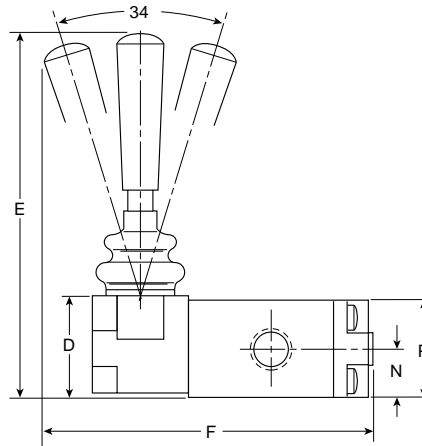
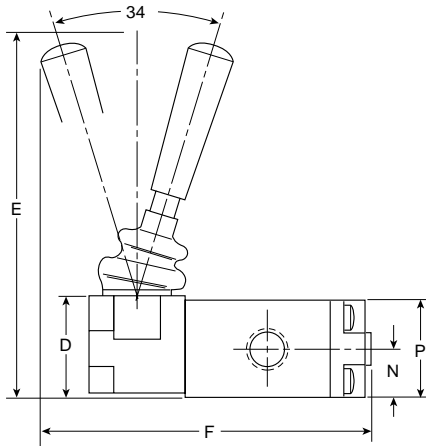

Pedal Operated

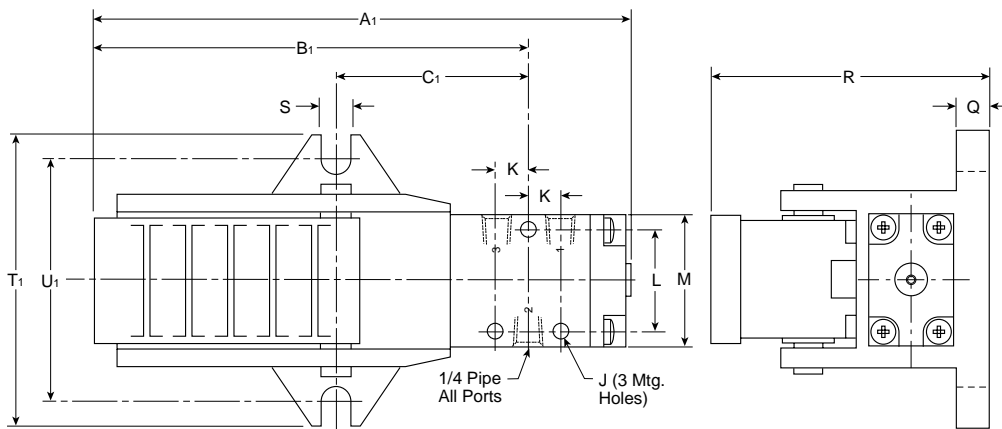

CAUTION:

*This valve shall not be used to actuate a punch press.
Do not use this valve on punch presses or press
brakes. See OSHA 1910.217.
See Accessories page for Pedal Guard Kit.*

D

Button, Roller, Pedal & Treadle Operated

4-Way, 5-Port, 2-Position

Button Operated

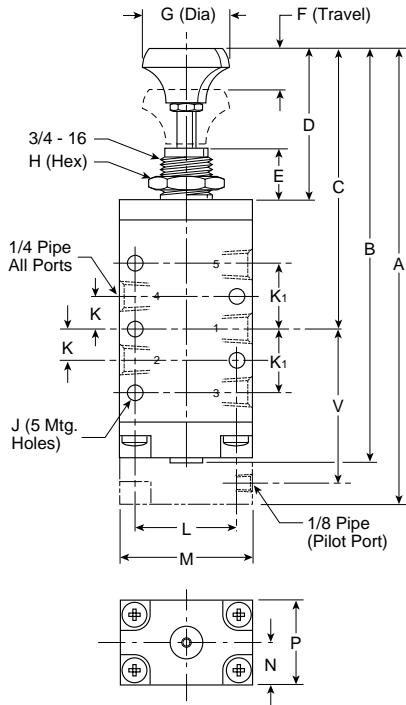

Roller Operated

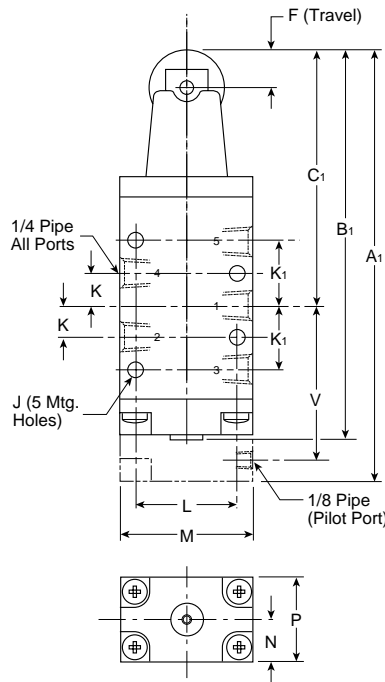

4-Way, 5-Port, 2-Position

A 5.75 (146)	A₁ 5.13 (130)	A₂ 7.41 (189)	B 5.28 (134)	B₁ 4.66 (118)
B₂ 5.63 (143)	C 3.50 (89)	C₁ 2.88 (73)	C₂ 2.64 (67)	D 2.00 (51)
E .63 (16)	F .32 (8)	G 1.05 (27)	H 1.00 (25)	J .19 (5)
K .44 (11)	K₁ .84 (21)	L 1.25 (32)	M 1.63 (41)	N .53 (14)
P 1.06 (27)	Q .37 (10)	R 2.40 (61)	S .34 (9)	T 3.50 (89)
U 3.00 (76)	V 1.96 (50)			

Inches (mm)

Pedal and Treadle Operated

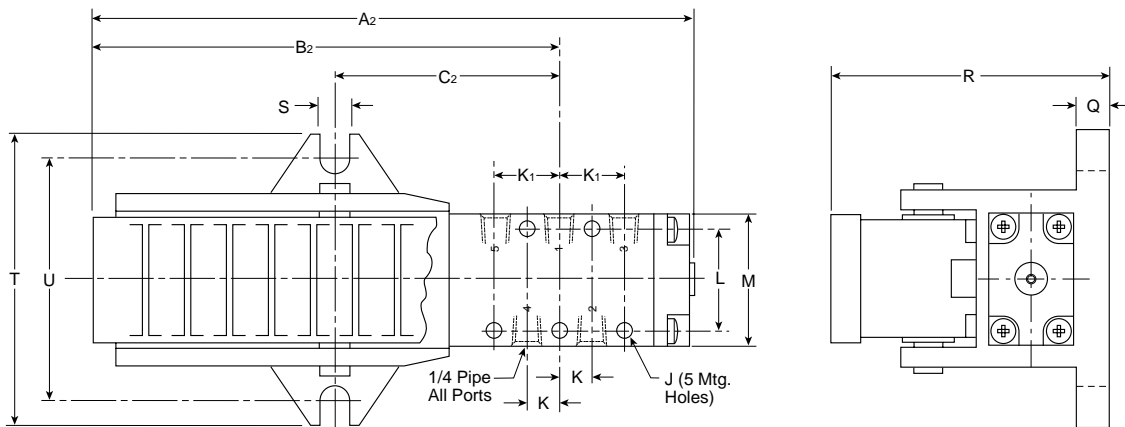

CAUTION:

*This valve shall not be used to actuate a punch press.
Do not use this valve on punch presses or press
brakes. See OSHA 1910.217.
See Accessories page for Pedal Guard Kit.*



Lever Operated

4-Way, 5-Port, 2 & 3-Position

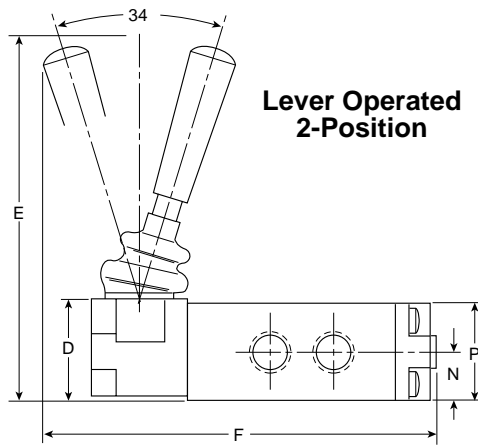
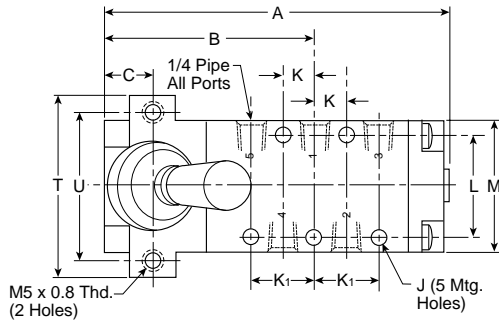

**4-Way, 5-Port,
2 & 3-Position**

A 4.19 (106)	A₁ 5.09 (129)	B 2.41 (61)	C .53 (14)	D 1.12 (28)
E 4.06 (103)	F 4.78 (121)	F₁ 5.78 (147)	J .19 (5)	K .44 (11)
K₁ .84 (21)	L 1.25 (32)	M 1.63 (42)	N .53 (14)	P 1.06 (27)
T 2.13 (54)	U 1.75 (44)			

Inches (mm)

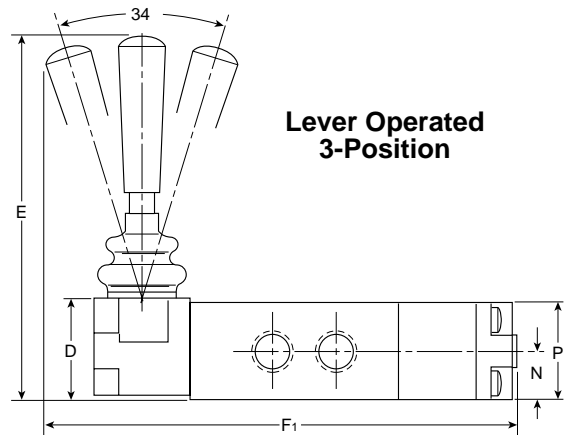
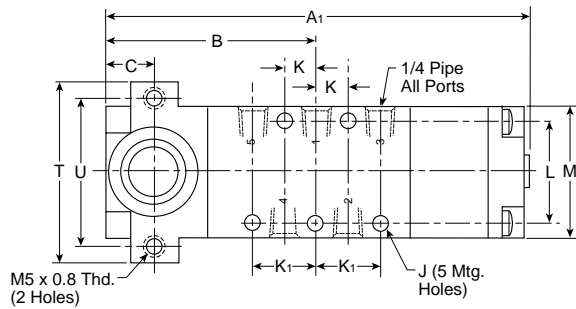

D



"42" Series

Lever / Pedal Valves

4-Way, 5-Port, 2 & 3-Position

Section E

www.parker.com/pneu/42ser

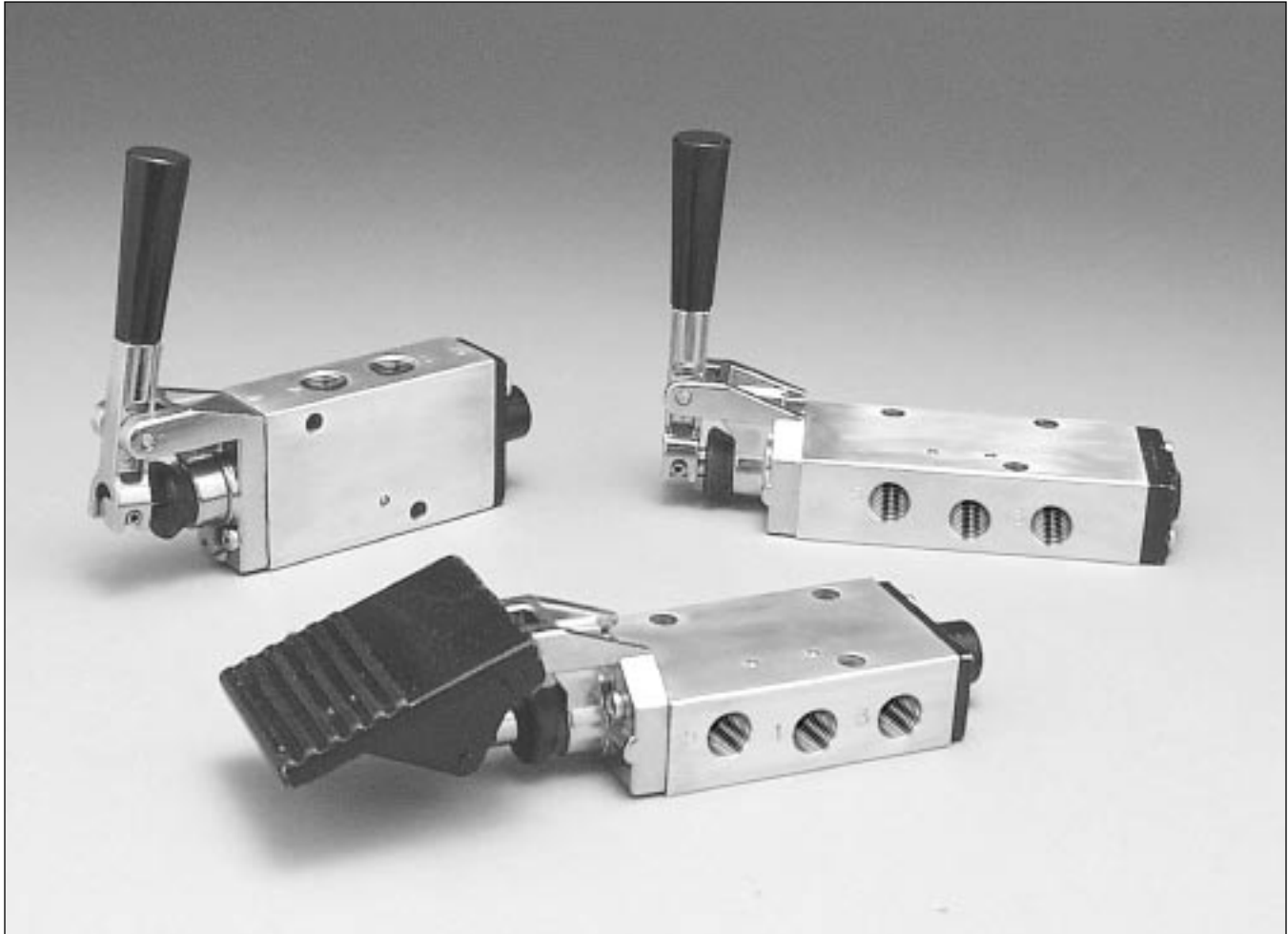

E

Basic Valve Functions	E2
"42" Series Basic Valve Features	E3
Common Part Numbers.....	E4
Model Number Index & Accessories	E5
Dimensions	
Lever Valve	E6
Foot Pedal Valve, Foot Pedal Guard.....	E7

BOLD ITEMS ARE MOST POPULAR.

Standard text part numbers may have longer lead times.



Lever Valves – Parallel & Perpendicular Operated

2-Position, Spring Return

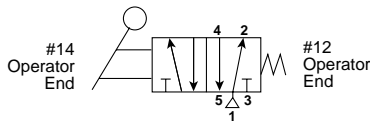

Single Pressure at Port #1 – The Hand Lever alternately pressurizes port 2 or 4 while exhausting at port 3 or 5. When actuating Hand Lever, port 4 is pressurized; when releasing Hand Lever, spring returns the spool, pressurizing port 2.

Dual Pressure – Pressure at port 3 & 5 alternately pressurizes port 2 or 4 while exhausting at port 1. When actuating Hand Lever, port 2 is pressurized; when releasing Hand Lever, spring returns the spool, pressurizing port 4. (Must be ordered as dual pressure)

2-Position, Detent

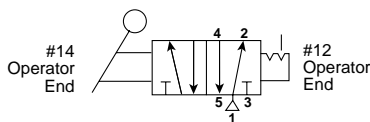

Single Pressure at Port #1 – The Hand Lever alternately pressurizes port 2 or 4 while exhausting at port 3 or 5. When pulling Hand Lever, port 4 is pressurized; when pushing Hand Lever, port 2 is pressurized. Spool stays in last actuated position.

Dual Pressure – Pressure at port 3 & 5 alternately pressurizes port 2 or 4 while exhausting at port 1. When pulling Hand Lever, port 2 is pressurized; when pushing Hand Lever, port 4 is pressurized. Spool stays in last actuated position. (Must be ordered as dual pressure.)

3-Position, Detent

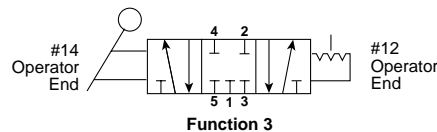

Function 3

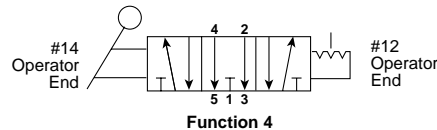

Function 4

Single Pressure at Port #1 – The Hand Lever alternately pressurizes port 2 or 4 while exhausting at port 3 or 5. When pulling Hand Lever, port 4 is pressurized; when pushing Hand Lever, port 2 is pressurized. When Hand Lever is vertical, it is in the center position - either APB or CE. Spool stays in last actuated position.

Center Functions

All Ports Blocked – Function 3

Center Exhaust – Function 4

CAUTION:
 For 3-Position lever function, do not restrict exhaust ports with speed controls.

E

Foot Pedal Operated

2-Position, Spring Return

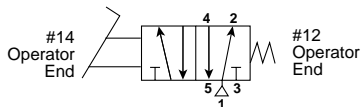

CAUTION:
 This valve shall not be used to actuate a punch press. Do not use this valve on punch presses or press brakes. See OSHA 1910.217.
 See Dimension page for Pedal Guard Kit.

Single Pressure at Port #1 – The Foot Pedal alternately pressurizes port 2 or 4 while exhausting at port 3 or 5. When pressing Foot Pedal down, port 4 is pressurized; when releasing Foot Pedal, spring returns the spool, pressurizing port 2.

Dual Pressure – Pressure at port 3 & 5 alternately pressurizes port 2 or 4 while exhausting at port 1. When pressing Foot Pedal down, port 2 is pressurized; when releasing Foot Pedal, spring returns the spool, pressurizing port 4. (Must be ordered as dual pressure)

"42" Series

Specifications

Heavy Duty Lever

- Parallel Mount
- Perpendicular Mount

Heavy Duty Foot Pedal

Inline Valve

- 1/4" Port – 1.3 to 2.2 Cv
- 3/8" Port – 1.3 to 2.9 Cv

2-Position

3-Position

- All Ports Blocked
- Center Exhaust

Operating Pressure

- Vacuum to 150 PSI
(710mm HG to 1035 kPa)

Operating Temperature

- 0°F to 140°F (-18°C to 60°C)

Flow Rating (Cv)

Port Size	Mounting Style	2-Position	3-Position
1/4" Ports	Inline	2.2	1.3
3/8" Ports	Inline	2.9	1.3



Lever Valve – Parallel



Foot Pedal Valve

E

Lever Valve – 2-Position
 (Parallel Shown)

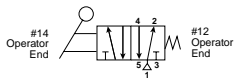

Spring Return

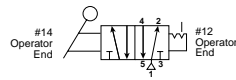

Detented

Lever Valve – 3-Position
 (Perpendicular Shown)

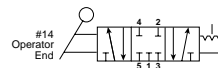

APB

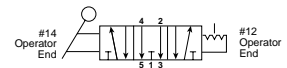

CE

Inline – Parallel

Single Pressure	Return	Port
422CS011K	Spring	1/4" NPT
422CS021K		3/8" NPT
422CS011W	Detent	1/4" NPT
422CS021W		3/8" NPT

Inline – Parallel

Single Pressure	Type	Port
422CS013W	3-Pos APB	1/4" NPT
422CS023W		3/8" NPT
422CS014W	3-Pos CE	1/4" NPT
422CS024W		3/8" NPT

Inline – Perpendicular

Single Pressure	Return	Port
422CR011K	Spring	1/4" NPT
422CR021K		3/8" NPT
422CR011W	Detent	1/4" NPT
422CR021W		3/8" NPT

Inline – Perpendicular

Single Pressure	Type	Port
422CR013W	3-Pos APB	1/4" NPT
422CR023W		3/8" NPT
422CR014W	3-Pos CE	1/4" NPT
422CR024W		3/8" NPT

Foot Pedal Valve – 2-Position

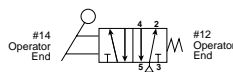

Spring Return

Inline

Single Pressure	Type	Return	Port
422CT011K	2-Pos	Spring	1/4" NPT
422CT021K			3/8" NPT



CAUTION:

This valve shall not be used to actuate a punch press. Do not use this valve on punch presses or press brakes. See OSHA 1910.217.

See Dimensions page for Pedal Guard Kit.

“42” Series

BOLD OPTIONS ARE MOST POPULAR

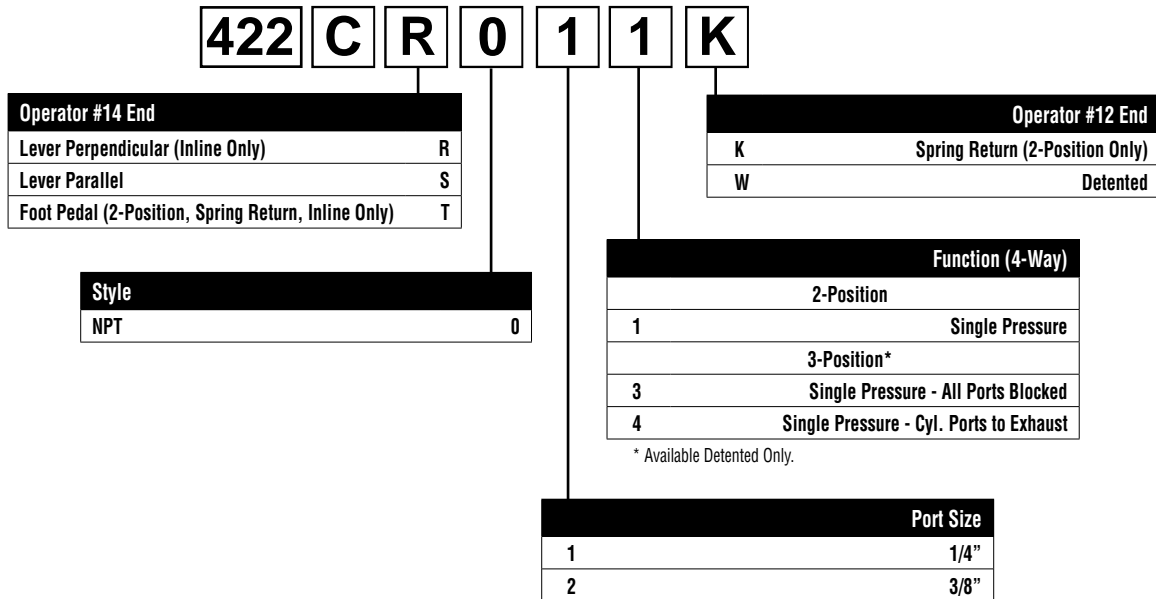

Valve Body Service Kits

Function / Operator	Single Pressure	Dual Pressure
2-Position / Manual	PS2038P	PS2039P
3-Position / Manual, Detented	PS2041P	

Kit includes: all soft seals and spool.



Lever Valve

2-Position

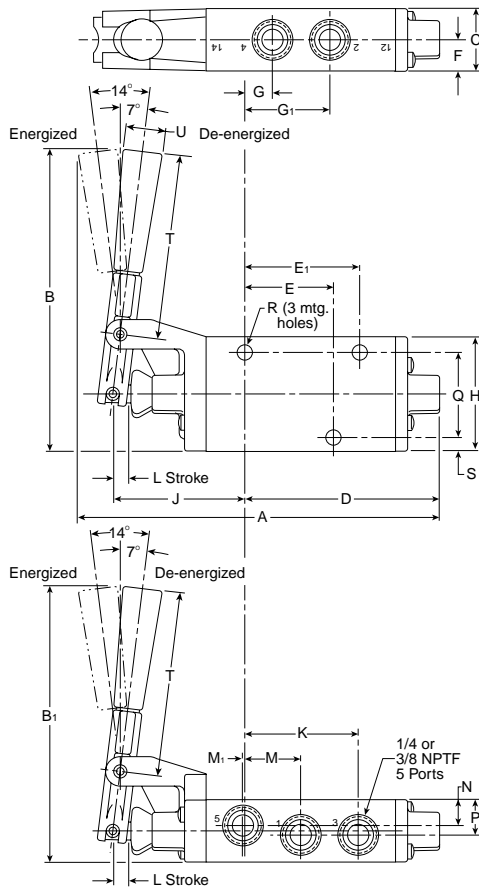

3-Position

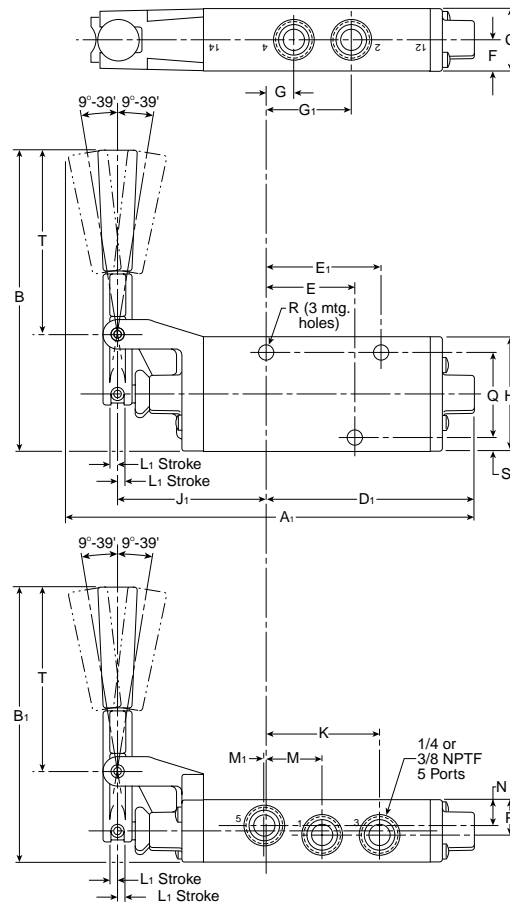

Lever Valve

A	A₁	B	B₁	C
6.70 (170)	7.58 (193)	5.55 (141)	5.05 (128)	1.15 (29)
D	D₁	E	E₁	F
3.59 (91)	3.83 (97)	1.58 (40)	2.06 (52)	.57 (14)
G NPT		G₁ NPT		H
1/4" .51 (13) 3/8" .55 (14)		1/4" 1.56 (40) 3/8" 1.51 (38)		2.13 (54)
J	J₁	K NPT		L
2.44 (62)	2.80 (71)	1/4" 2.08 (53) 3/8" 2.13 (54)		.25 (6)
L₁	M	M₁ NPT		N
.18 (5)	1.03 (36)	1/4" .02 (.5) 3/8" .06 (2)		.50 (13)
P	Q	R	S	T
.65 (17)	1.58 (40)	.33 (8)	.27 (7)	3.42 (87)
U Dia				
.75 (19)				

Inches (mm)

E

Foot Pedal Valve

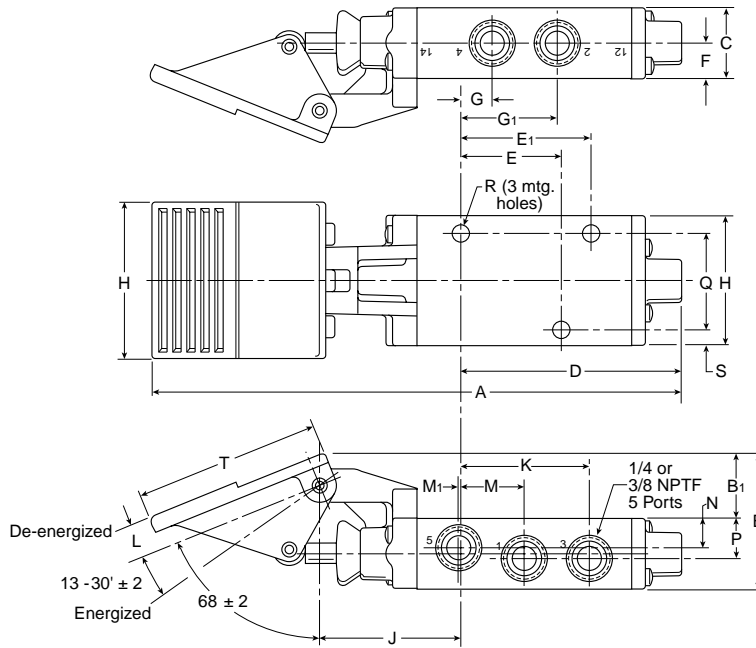

Foot Pedal Valve

A 8.64 (220)	B 2.18 (55)	B₁ 1.03 (26)	C 1.15 (29)	D 3.59 (91)
E 1.58 (40)	E₁ 2.06 (52)	F .57 (14)	G NPT 1/4" .51 (13) 3/8" .55 (14)	
G₁ NPT 1/4" 1.56 (40) 3/8" 1.51 (38)		H 2.13 (54)	H₁ 2.50 (64)	J 2.32 (59)
K NPT 1/4" 2.08 (53) 3/8" 2.13 (54)		L .60 (15)	M 1.03 (26)	
M₁ NPT 1/4" .02 (.5) 3/8" .06 (2)		N .50 (13)	P .65 (17)	Q 1.58 (40)
R .33 (8)	S .27 (7)	T 3.00 (76)	U .48 (11)	

Inches (mm)



CAUTION:

*This valve shall not be used to actuate a punch press.
Do not use this valve on punch presses or press brakes.
See OSHA 1910.217.*

Foot Pedal Valve Guard

To order Foot Pedal Valve Guard, specify part number PS2043P.

This kit contains the valve mounting hardware.

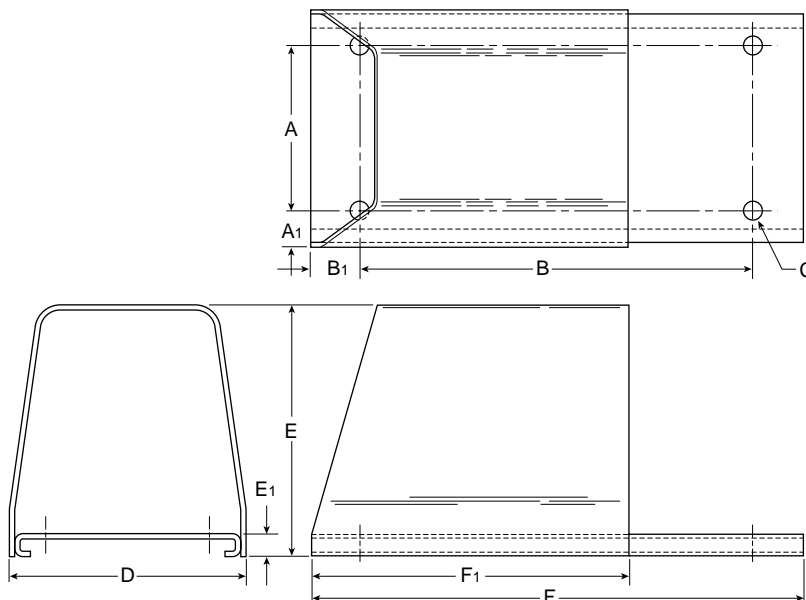

Foot Valve Guard

A 4.50 (114)	A₁ .75 (19)	B 10.50 (267)	B₁ 1.25 (32)	C .48 (11)
D 6.00 (152)	E 7.13 (181)	E₁ .50 (13)	F 13.00 (330)	F₁ 8.38 (213)

Inches (mm)



E



“DX” ISOMAX Series

Directional Control Valves

15407-1 & 5599-1

DX02 – 0.55 Cv

DX01 – 0.75 Cv

DX1 – 1.15 Cv

DX2 – 2.50 Cv

DX3 – 4.15 Cv

Section F

www.parker.com/pneu/isomax

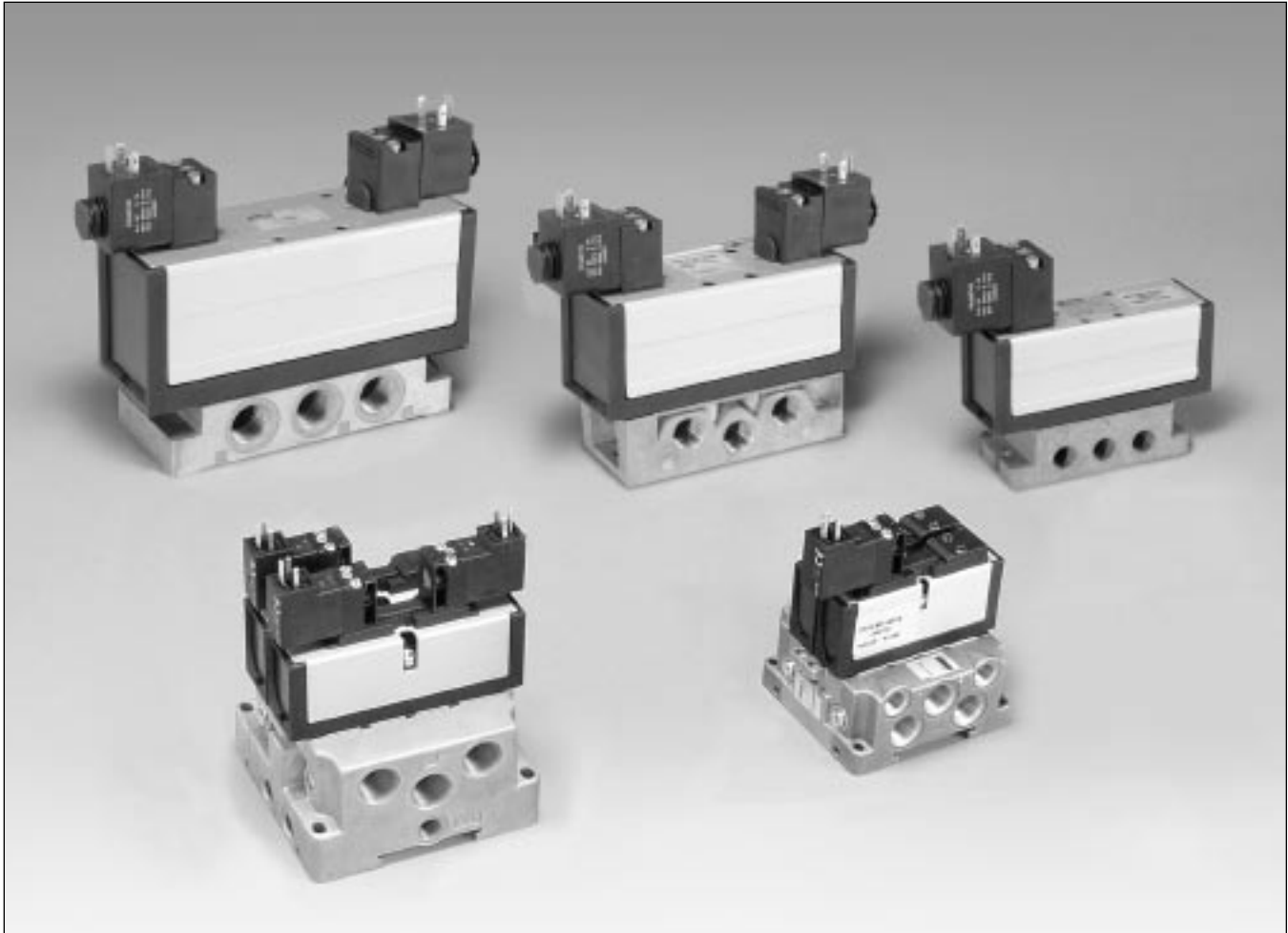

ISOMAX 15407-1 Ceramic, DX02 & DX01

Valve Range & Features.....	F2
Features.....	F3
Specifications.....	F4
Common Part Numbers.....	F5
Model Number Index.....	F6
Add-A-Fold Ordering Information.....	F7
Subbases & Manifolds.....	F8-F11
Accessories.....	F12-F14
Selector Gasket Conversion Instructions.....	F15-F16
DX01 Manifold Assembly & Conversion Instructions.....	F17-F20
DX02 Manifold Assembly.....	F21-F23

Subbase Assembly.....	F24
Dimensions.....	F25-F26
ISOMAX 5599-1 Ceramic, DX1 1/4", DX2 3/8", DX3 1/2"	
Specifications.....	F27
Common Part Numbers.....	F28
Model Number Index.....	F29
Add-A-Fold Assemblies.....	F30
Accessories.....	F31-F35
Electrical Connectors.....	F36
Internal / External Pilot Conversion Instructions.....	F37
Dimensions.....	F38-F42

BOLD ITEMS ARE MOST POPULAR.





Valve Range

DX02 1/8", ISO 15407-1, Size 02

DX01 1/4", ISO 15407-1, Size 01

DX1 1/4", ISO 5599-1, Size 1

DX2 3/8", ISO 5599-1, Size 2

DX3 1/2", ISO 5599-1, Size 3



ISO 15407-1

The ISOMAX range of directional control valves complies with ISO 15407-1 and VDMA 24563 for sizes 02 and 01 and ISO 5599-1 for sizes 1, 2 and 3. ISOMAX provides flows from 0.55 Cv to 4.15 Cv.



ISO 5599-1

The ISOMAX range includes valves for pneumatic and electrical actuation with a wide choice of subbases and manifolds to suit different application needs.

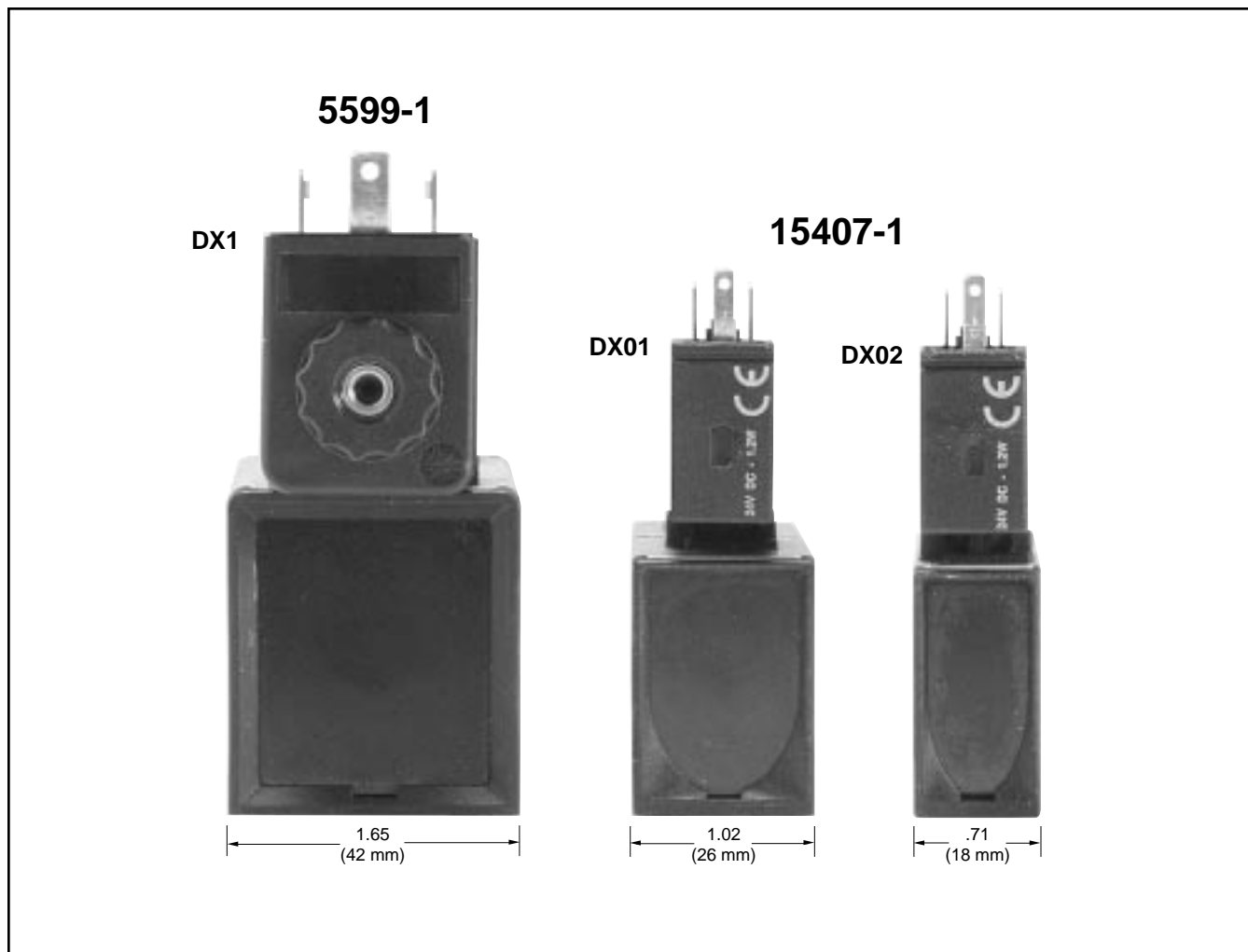

F

Corrosion Free and Modern Design

With the valve body in Polyamide reinforced fiberglass and the casing in anodized aluminium, the complete ISOMAX range presents a coherent modern design to suit most industrial environments.

Dual Pressure

In order to supply 2 different pressures to the same actuator, it is possible to connect 2 main pressure supplies to the exhaust ports and use the pressure port 1 as exhaust port.

Vacuum Operation

All ISOMAX valves may be used for either vacuum or pressure applications.



Features

Ceramic Technology

All ISOMAX products use high-tech ceramic switching technology providing:

- **Excellent Reliability**
 Long life in excess of 100 million operations*.
 Operates with lubricated or non-lubricated air.
 Low sensitivity to air quality changes.
- **High Performance**
 Slide valve concept allows high flow / size ratio and short response time due to short slide stroke and low friction.
- **Stable Long Lasting Performances**
 Low friction switching: minimum wear of the valve member / seal assembly.
- **Valves Fitted with Switchable Selector to Give Internal or External Pilot Supply**

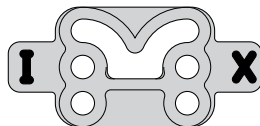
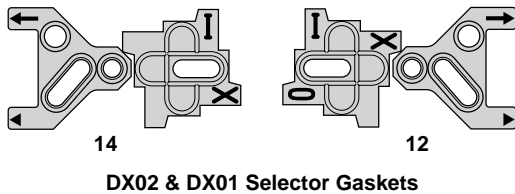

DX1, DX2 & DX3 Selector Gasket

Applicable Markets

Industries where ISO standardization is accepted.

- Automotive
- Food Processing
- Medical
- Chemical
- Tire Manufacturing
- Steel Processing
- Glass Processing
- Where OEM'S Export Globally

* Refer to our warranty conditions.

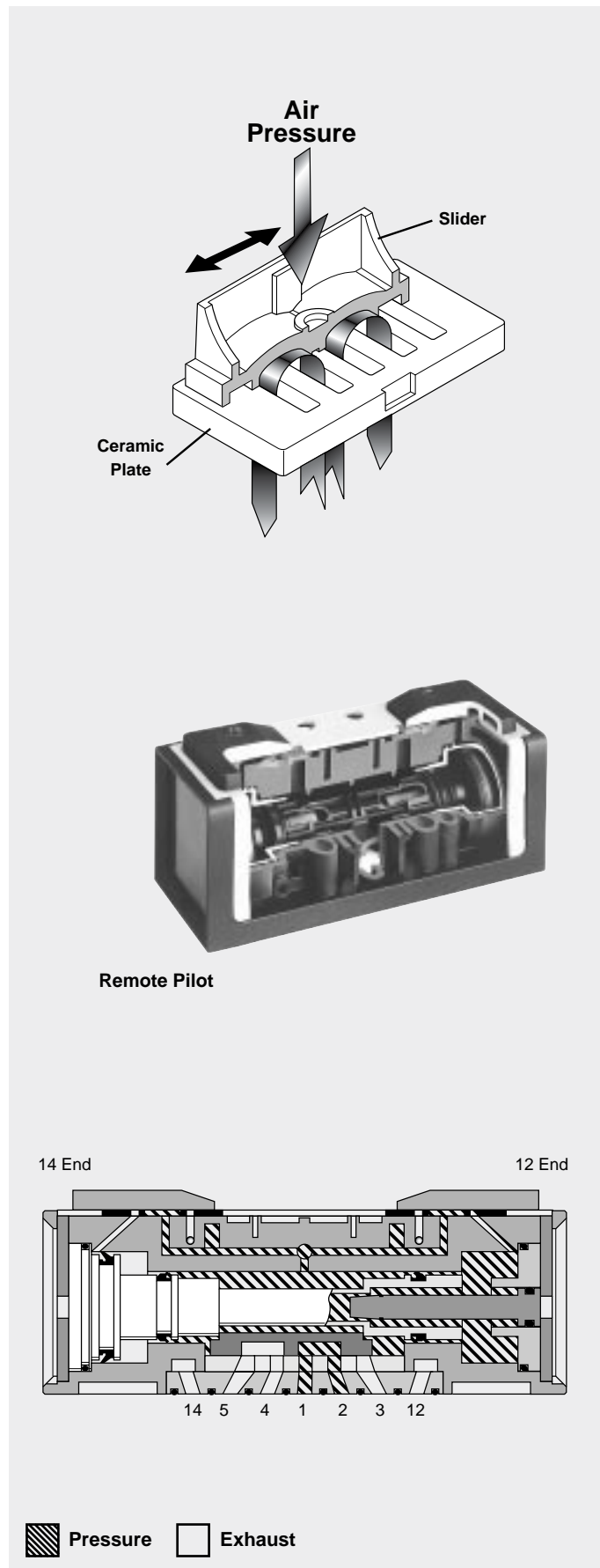



ISOMAX 15407-1



Specifications

Standard Subbase:

ISO 15407-1 and VDMA 24563

Permissible Fluid

Air or Inert Gas, filtered 40µ (Class 5 per ISO 8573-1),
 Lubricated or Non-lubricated

Pressure Supply:

Possible to supply Exhaust Ports 3 or 5 or Cylinder
 Ports 2 or 4, with Internal Pilot Supply. (Not possible
 with APB).

Flow:

DX01 = .75Cv, DX02 = .55Cv

Working Temperatures:

-10°C to 60°C (14°F to 140°F)

Storage Temperatures:

-20°C to 70°C (-4°F to 158°F)

Mechanical Life:

> 100 million operations (Dry air filtered 40µ, 2Hz,
 6 bar, 20°C)

Actuation Type:

Electric / Pneumatic with 15mm Solenoid Valve
 Interface CNOMO E06.36120N

Flow Rating (Cv)

Size	Port Size	Mounting Style	2-Position	3-Position
DX02	1/8"	Manifold	0.45	0.35
		Subbase	0.55	0.40
DX01	1/4"	Manifold	0.70	0.45
		Subbase	0.75	0.50

Cv tested per ANSI / (NFPA) T3.21.3

Solenoid Information

Code	Voltage			Power (W / VA)
	AC		DC	
	60Hz	50Hz		
M	—	—	24	1.2W
J	120	110	—	1.6VA

Data tested with LED and Surge Suppression.

Response Time**

Single Solenoid 2-Position - Air Return / Spring Assist

Valve Size	Port Size	0 Cu. In. Chamber		## Cu. In. Chamber	
		Fill	Exhaust	Fill	Exhaust
DX02	1/8"	0.025	0.030	0.125	0.220
DX01	1/4"	0.015	0.020	0.122	0.200

DX01 (25), DX02 (12.5)

** With 100 PSIG supply, time required to fill from 0 to 90 PSIG and Exhaust
 from 100 PSIG to 10 PSIG measured from the instant of energizing or
 de-energizing 24VDC solenoid.

Tested per ANSI / (NFPA) T3.21.8

Operating Pressure

Vacuum to 145 PSIG (10 bar)

Function	M.O.P (PSIG)	
20, 21, 22, 23	2-Position, Spring Return	36
50, 51, 53, 54	2-Position, Air Return	30
04, 05, 06, 08	2-Position	15
09, 11, 12, 27	3-Position, CE	45
16, 18, 19, 25	3-Position, APB	45
13, 14	3-Position, PC	45

Material Specifications

- Valve Member Self Lubricating Acetal
- Seat Ceramic
- Body Polyamide Reinforced Fiberglass
- Casing Anodized Aluminum
- End Plates Painted Zinc Plated Steel
- Valve Plate Zinc
- Seals Nitrile
- Springs Stainless Steel
- Screws Zinc Plated Steel
- Function Selector Polyamide Reinforced Fiberglass
- Top Cover Seal Polyester

F



Single Solenoid

2-Position

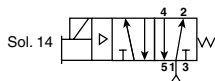
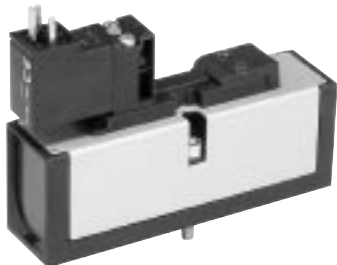

DX02	DX02-621-951J	120VAC	.55 Cv
	DX02-621-951M	24VDC	
DX01	DX01-621-951J	120VAC	.75 Cv
	DX01-621-951M	24VDC	

Double Solenoid

2-Position

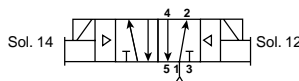
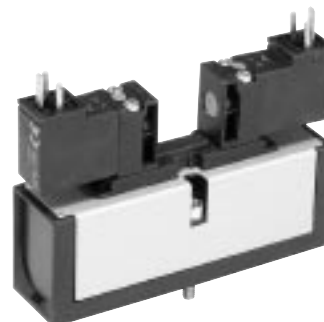

DX02	DX02-606-951J	120VAC	.55 Cv
	DX02-606-951M	24VDC	
DX01	DX01-606-951J	120VAC	.75 Cv
	DX01-606-951M	24VDC	

Double Solenoid

3-Position APB

3-Position CE

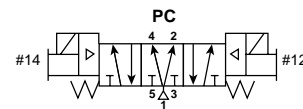
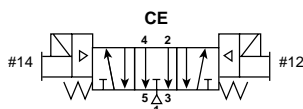
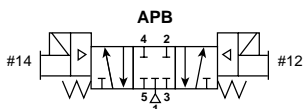
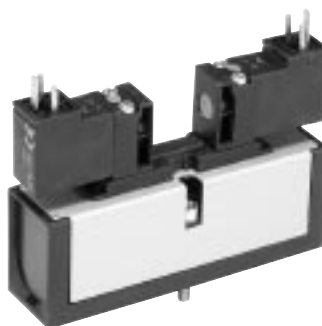

APB				CE				PC			
DX02	DX02-616-951J	120VAC	.40 Cv	DX02-611-951J	120VAC	.40 Cv	DX02-613-951J	120VAC	.40 Cv		
	DX02-616-951M	24VDC		DX02-611-951M	24VDC		DX02-613-951M	24VDC			
DX01	DX01-616-951J	120VAC	.50 Cv	DX01-611-951J	120VAC	.50 Cv	DX01-613-951J	120VAC	.50 Cv		
	DX01-616-951M	24VDC		DX01-611-951M	24VDC		DX01-613-951M	24VDC			

Torque Specifications

DX02: 15 to 25 in-lbs (1.69 to 2.82 Nm)

DX01: 20 to 30 in-lbs (2.26 to 3.39 Nm)

For Subbases and Manifolds, see page F8 thru F10.





BOLD OPTIONS ARE MOST POPULAR

DX02 – **6** **06** – **95** **1** **M**

Basic Series	
ISO 15407-1 (18mm)	DX02
ISO 15407-1 (26mm)	DX01

Pilot	
Air Operated Remote Pilot	4
Solenoid Operated	6

Function	
Internal Pilot Supply / Captured Exhaust 12	
2-Position, Spring Return	21
2-Position, Air Return	51
2-Position	06
3-Position, CE	11
3-Position, APB	16
3-Position, PC	13
External Pilot 14 Supply / Captured Exhaust 12*	
2-Position, Spring Return	23
2-Position, Air Return	54
2-Position	05
3-Position, CE	09
3-Position, APB	19
3-Position, PC	14
Internal Pilot Supply / Vented Exhaust	
2-Position, Spring Return	20
2-Position, Air Return	50
2-Position	04
3-Position, CE	27
3-Position, APB	25
External Pilot Supply / Vented Exhaust*	
2-Position, Spring Return	22
2-Position, Air Return	53
2-Position	08
3-Position, CE	12
3-Position, APB	18

* Must be specified when using Sandwich Regulators.

Voltage & Frequency			
	AC		DC
	60Hz	50Hz	
J	120	110	
M			24
Blank	Rempte Pilot		

Override	
Blank	Remote Pilot
1	Non-Locking, Flush
3	Locking, Flush

Operator	
60	None, Remote Pilot Valve
95	15mm, 3-Pin, DIN 43650C

F

Note: DX02 18mm Valve Remote Pilot Option only available with PL02 Individual Subbase Kits

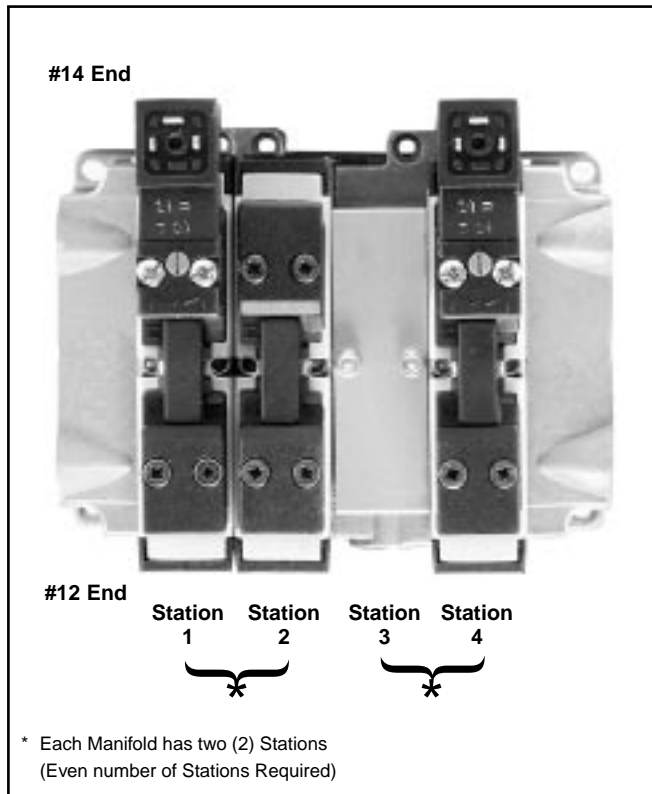

How To Order Add-A-Fold Assemblies

1. List Add-A-Fold Assembly call out. This automatically includes the end plate kit assembly.
2. List complete valve/base model number. List left to right, looking at the cylinder ports on the #12 end of the manifold. The left most station is station 1.
(If a blank station is needed, list the blanking plate part number and the individual manifold number in the station specified.)

Model Number

AA 02 U 0 04

Valve Series	
Right & Left End Plate 15407-1, DX01	01†
Right & Left End Plate 15407-1, DX02	02†
Right & Left End Plate 15407, DX01 & DX02	HB*

* Common End Plates for DX01 & DX02.
† Must be used with End Plate Type "U".

End Plate Type	
HB Non-Collective Wiring	S
01 & 02 Non-Collective Wiring	U*

* Must be used with Valve Series 02 & 01.

Number of Stations*	
02	2 Stations
04	4 Stations
•	
24	24 Stations
•	
32†	32 Stations

* Must be ordered in multiples of 2.
† Maximum Number.

Port Type	
0	NPT
1	BSPP "G"

Example: Application requires a 3-Valve manifold.

Qty.	Part No.
1	AA02U004
1	DX02-651-951M Valve Station 1
1	DX02-406-60 Valve Station 2
1	PJLP02-201-80 Base Station 1 & 2
1	DX02BLK Valve Station 3
1	DX02-651-951M Valve Station 4
1	PJLP02-201-80 Base Station 3 & 4

Note: DX02 Manifolds cannot be used for remote pilot.





Individual Subbase Kit
with Side Ports

Size	Port Size	Kit Number	
		NPT	BSPP “G”
18mm DX02	1/8"	PL02-01-80	PL02-01-70

Note: Can be used for external, single, or double remote pilot.

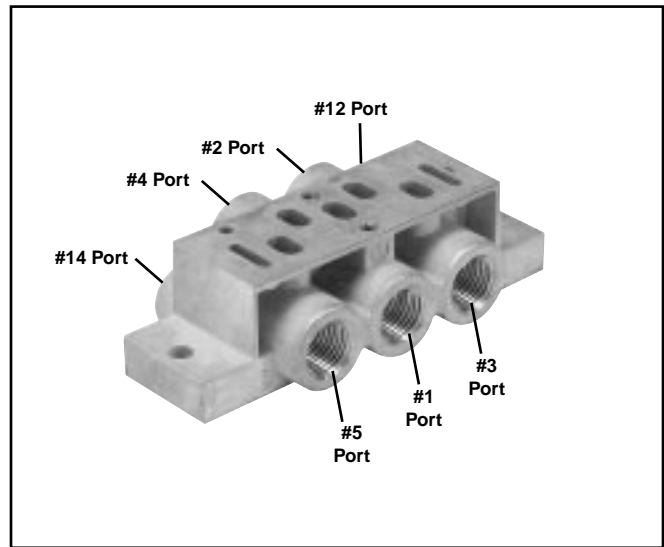

Two Station Manifold Base
with Side Ports

Size	Port Size	Kit Number	
		NPT	BSPP “G”
18mm DX02	1/8"	PJLP02-201-80	PJLP02-201-70

Note: Can be used for external pilot, not remote pilot.
 Gaskets and assembly hardware included.

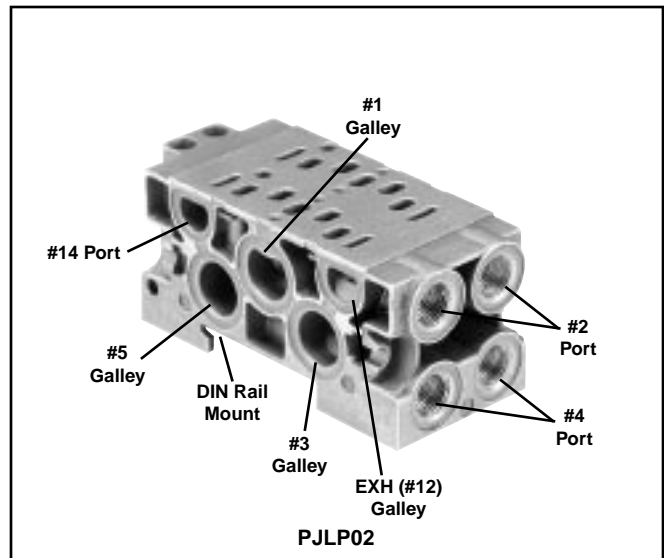

End Plate Kit
for Side Ported Two Station Manifold Base

Size	Port Size	Kit Number	
		NPT	BSPP “G”
18mm DX02	1/8"	PEJ02-02-80*	PEJ02-02-70

Notes: Put a vent or muffler in “EXH” port when capturing pilot exhaust pressure with a solenoid valve. (See page F18 for gasket selector details.
 Gaskets and assembly hardware included.
 Torque Specifications: 25 to 35 in-lbs (2.82 to 3.95 Nm)

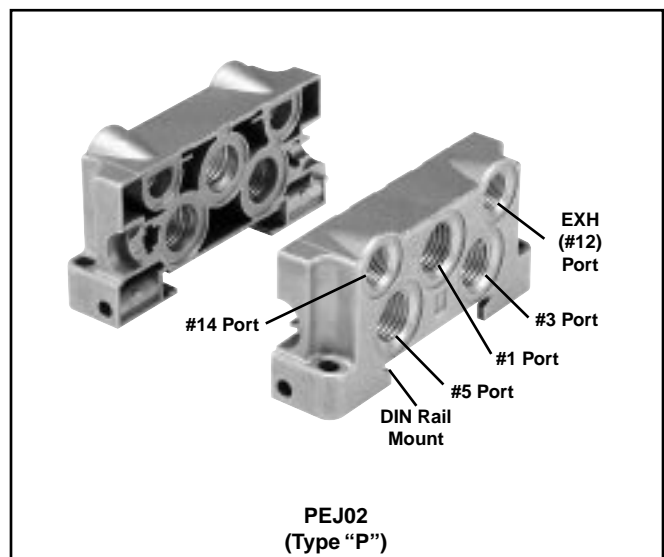

F



Individual Subbase Kit with Side Ports

Size	Port Size	Kit Number	
		NPT	BSPP "G"
26mm DX01	1/4"	PL01-02-80	PL01-02-70

Note: Can be used for external, single, or double remote pilot.

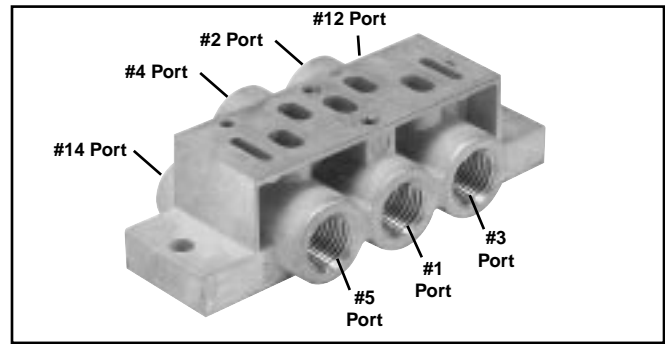

Two Station Manifold Base with Side Ports

Size	Port Size	Kit Number	
		NPT	BSPP "G"
26mm DX01	1/4"	PJLP01-202-80	PJLP01-202-70

Notes: Can be used for single remote pilot using the #14 Port and external pilot.

Gaskets and assembly hardware included.

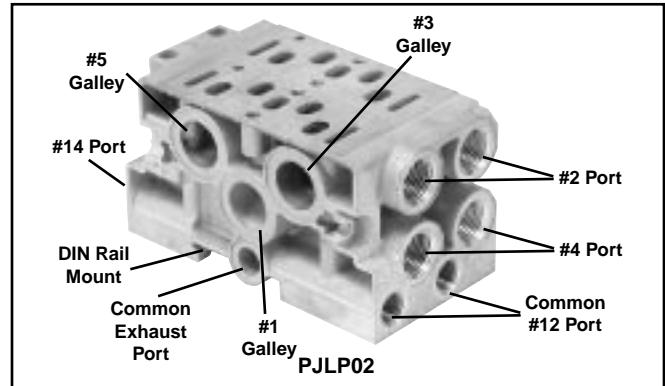

Size	Port Size	Kit Number	
		NPT	BSPP "G"
26mm DX01	1/4"	PJL01-202-80	PJL01-202-70

Notes: #12 ports work independently when plunger is not depressed by a plug. When a plug is inserted in #12 Port along with the captured pilot exhaust gasket selector option, pilot exhaust is sent to their Common Exhaust Port. Do Not plug exhaust, insert a vent or muffler.

Gaskets and assembly hardware included.

Can be used for external, single or double remote pilot.

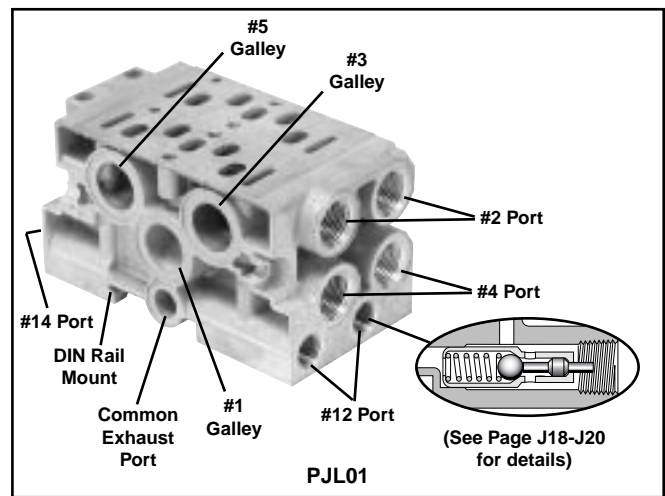

End Plate Kit for Side Ported Two Station Manifold Base

Size	Port Size	Kit Number	
		NPT	BSPP "G"
26mm DX01	1/4"	PEJ01-03-80*	PEJ01-03-70

* Use with PJLP01 or PJL01

Notes: Put a vent or muffler in "EXH" port when capturing pilot exhaust pressure with a solenoid valve. (See page F18 for gasket selector details.)

Gaskets and assembly hardware included.

Torque Specifications: 25 to 35 in-lbs (2.82 to 3.95 Nm)

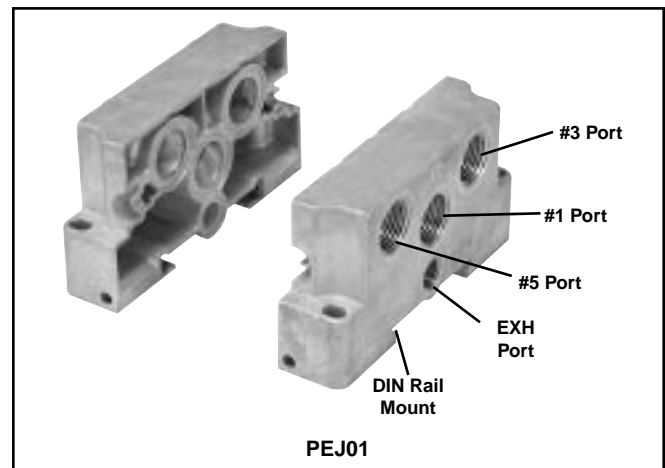



15407-1, DX02 & DX01 Manifold / Subbase Kits

PS5511 **13** **0** **P**

Basic Series	
ISO 15407-1 DX02	PS5611
ISO 15407-1 DX01	PS5511

Enclosures / Lead Length	
0	None, No Electrical Plug - 15407-1

Mounting Style / Port Size	
DX02	
Manifold with 1/8 NPT End Ports	51
Manifold with 1/8 BSPP End Port	52
Manifold with 1/8 NPT Bottom / End Port	61
Manifold with 1/8 BSPP Bottom / End Port	62
DX01	
Subbase with 1/4 NPT Side Ports	13
Subbase with 1/4 BSPP Side Ports	14
Subbase with 1/4 NPT Bottom / Side Port	23
Subbase with 1/4 BSPP Bottom / Side Port	24
Manifold with 1/4 NPT End Port	53
Manifold with 1/4 BSPP End Port	54
Manifold with 1/4 NPT Bottom / End Port	63
Manifold with 1/4 BSPP Bottom / End Port	64

Subbase Kits

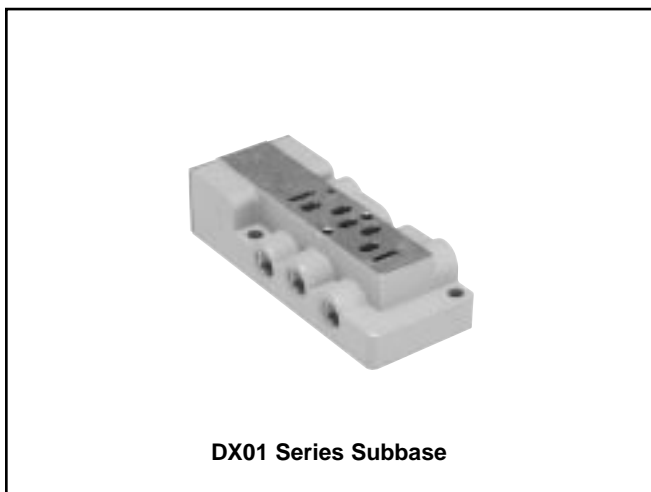

Manifold Kits

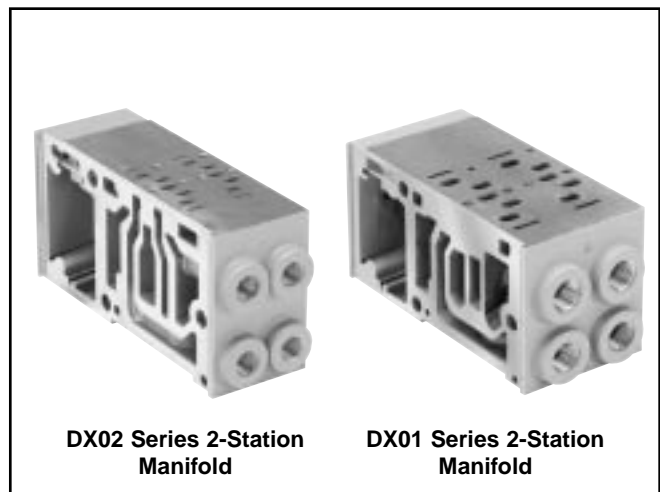

F



15407-1, DX02 & DX01 End Plate Kits

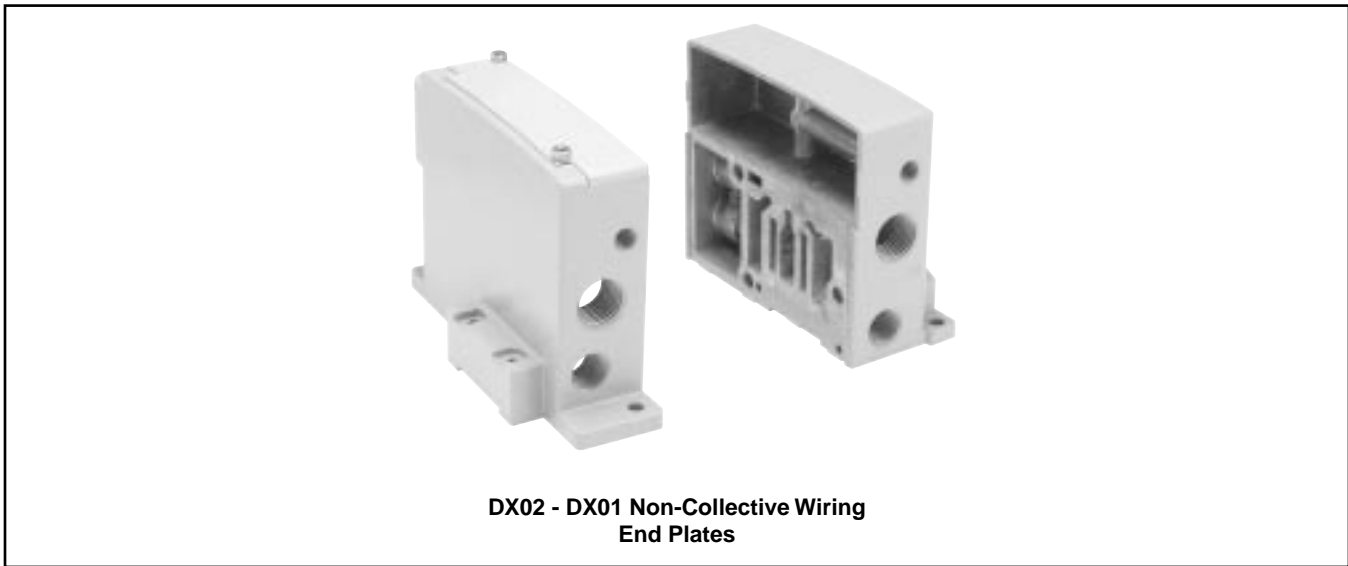
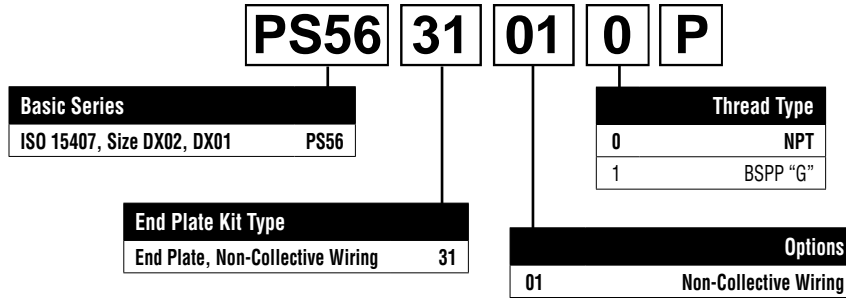

F



Sandwich Regulators Features

- Remote Air Pilot Operated for hard-to-reach pressure control.
- Unregulated Pilot Pressure to valve for consistent valve shifting regardless of pressure adjustment.

DX02
 (Independent Dual Port Regulator Shown)

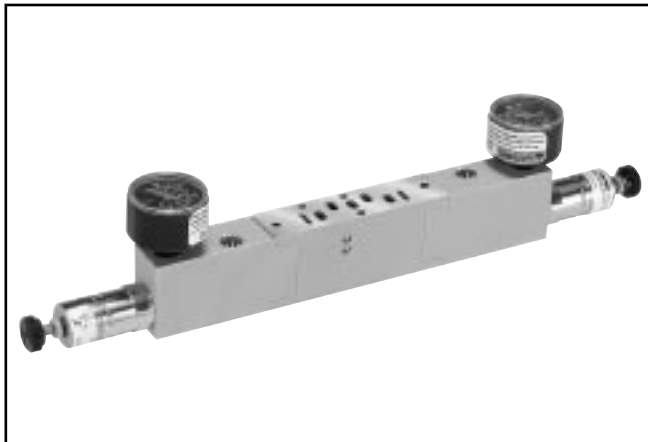

DX01
 (Common Port Regulator Shown)



BOLD OPTIONS ARE MOST POPULAR

PS5637 1 6 6 P

Basic Series	
DX02	
15407-1, 18mm	PS5637
DX01	
15407-1, 26mm	PS5537

Regulator Function	
Common Pressure Regulator	1
Independent Pressure Regulator	2

#2 Port Regulator / Gauge*	
2	2-60 PSIG w/o Gauge
3	5-125 PSIG w/o Gauge
5	2-60 PSIG w/Gauge
6	5-125 PSIG w/Gauge

* For Common Pressure Regulator Option, Regulator Gauge callout must be the same number for both Port #4 and Port #2. (Example: 166)

#4 Port Regulator / Gauge*	
2	2-60 PSIG w/o Gauge
3	5-125 PSIG w/o Gauge
5	2-60 PSIG w/Gauge
6	5-125 PSIG w/Gauge

* For Common Pressure Regulator Option, Regulator Gauge callout must be the same number for both Port #4 and Port #2. (Example: 166)

F



Intermediate Air Supply Base

Size	Port Size	Kit Number
		NPT
18mm DX02	1/8" NPT	D02P-01-80
26mm DX01	1/4" NPT	D01P-02-80

Notes: Gasket & Mounting Bolts included.
 Torque Specifications
 Size 02: 15 to 25 in-lbs (1.69 to 2.82 Nm)
 Size 01: 20 to 30 in-lbs (2.26 to 3.39 Nm)

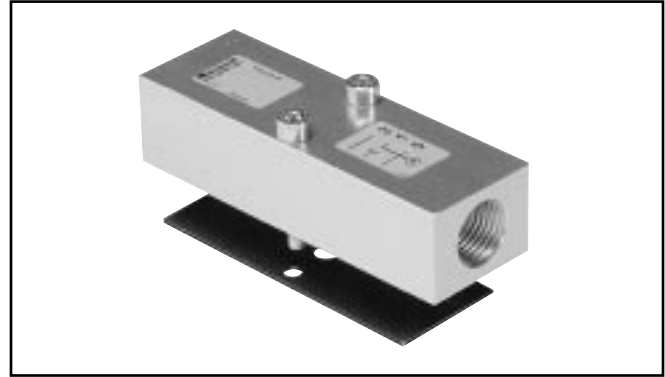

Manifold Port Isolation Disc

Size	Common Pressure
18mm DX02	D02BD0
26mm DX01	D01BD0

Note: 3 Discs per Kit.

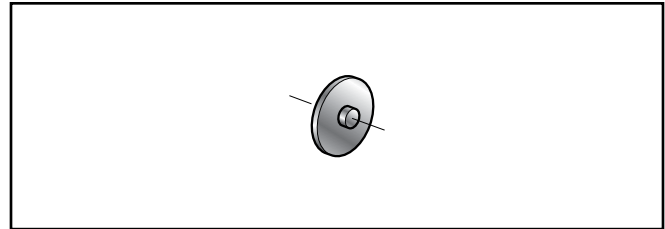

Blanking Plate

Size	Common Pressure
18mm DX02	DX02BLK
26mm DX01	DX01BLK

Notes: Gasket & Mounting Bolts included.
 Torque Specifications
 Size 02: 15 to 25 in-lbs (1.69 to 2.82 Nm)
 Size 01: 20 to 30 in-lbs (2.26 to 3.39 Nm)

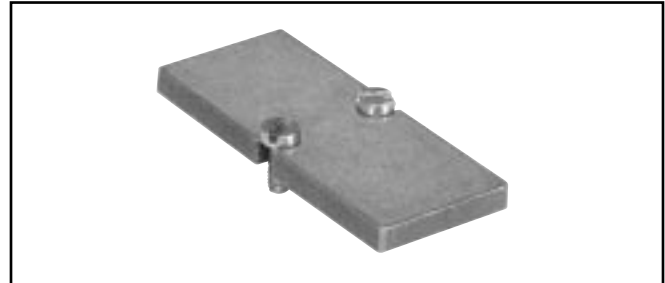

Sandwich Flow Control Features

- Both adjustment screws are located on the 12 end of the unit.
- Sandwich Flow Control mounts with its own studs, which means the valve uses standard bolts for mounting.
- Sandwich Flow Control is not to be used as a shut off device and is not bubble tight when needles are fully turned down.

Size	Kit Number
18mm DX02	PS5642P
26mm DX01	PS5542P

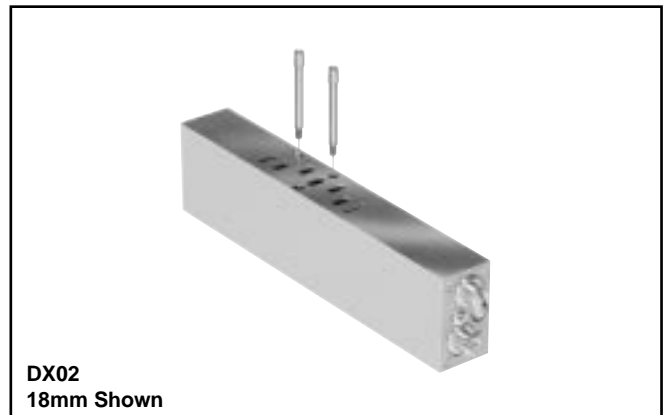



Manifold to Manifold Gasket Kits

Size	Standard	Blocked #1 Port	Blocked #1, 3, 5 Ports	Blocked #3, 5 Ports
DX02 *	PS561AP	PS561BP	PS561CP	PS561DP
DX01 *				
DX02	DX02M2MGSKT (PJLP02)			
DX01	DX01M2MGSKT (PJLP01)			

* Gaskets used with PS5611 & PS5511 Manifolds.

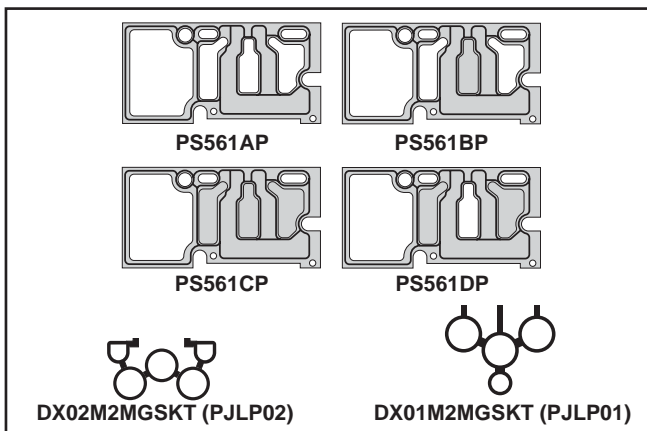

15mm 3-Pin DIN 43650C Connectors

Connector	Connector with 6' (2m) Cord	Description
PS2932BP	PS2932JBP	No Circuit Board
PS294679BP	PS2946J79BP*	Light – 24DC
PS294683BP	PS2946J83BP*	Light – 110/120VAC

* LED with surge suppression.

Note: Max. ø6.5mm cable size required for connector without 6' (2m) cord.
IP65 rated when properly installed.

Engineering Data:

Conductors: 2 Poles Plus Ground
Cable Range (Connector Only): 4 to 6mm (0.16 to 0.24 Inch)
Contact Spacing: 8mm

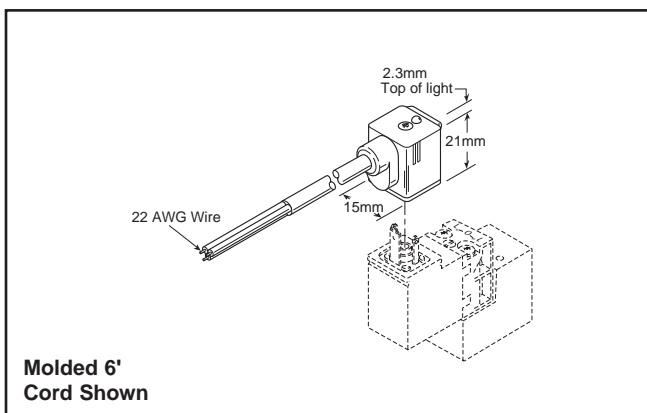

Molded 6' Cord Shown

15mm 3-Pin DIN 43650C Replacement Solenoid Kits

Voltage	Non-Locking	Locking
24VDC	PS2982B49P	PS2982C49P
110/50, 120/60	PS2982B53P	PS2982C53P

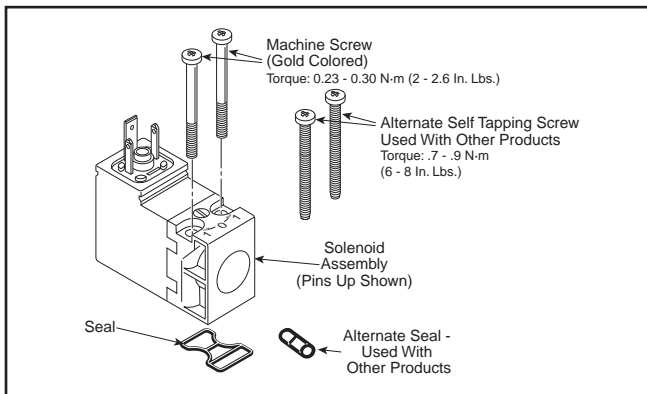

F

Manifold Bolt Kit

Part Number	Items
DX02M2MB**	Bolt, Washer & Nut*

* Includes 10 Bolts, 10 Washers, 10 Nuts

** Use this number for both sizes, DX02 & DX01.

Torque Specifications: 25 to 35 in-lbs (2.82 to 3.95 Nm)

Screws for: Size1 DX1..... CHC M5 x 40
Size2 DX2..... CHC M6 x 50
Size3 DX3..... CHC M8 x 60
(Screws also available in stainless steel)

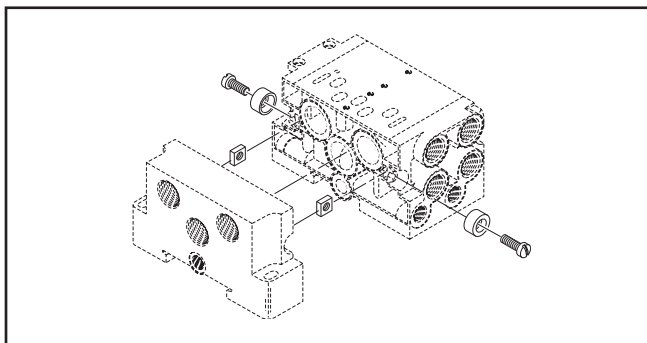



Changing from **Internal** to **External** Pilot Supply

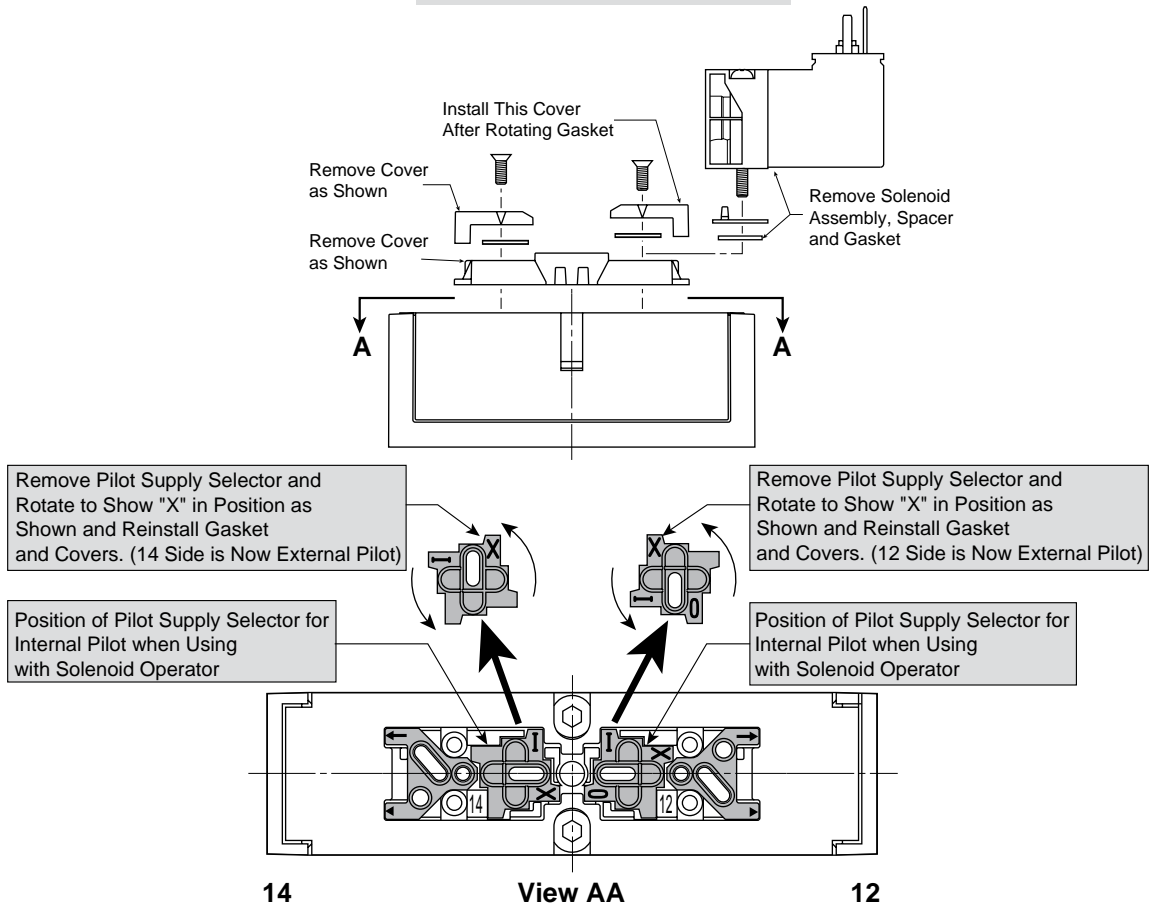

Changing from **External** Pilot Supply, Vented Pilot Exhaust to **Internal** Pilot Supply, Captured Pilot Exhaust

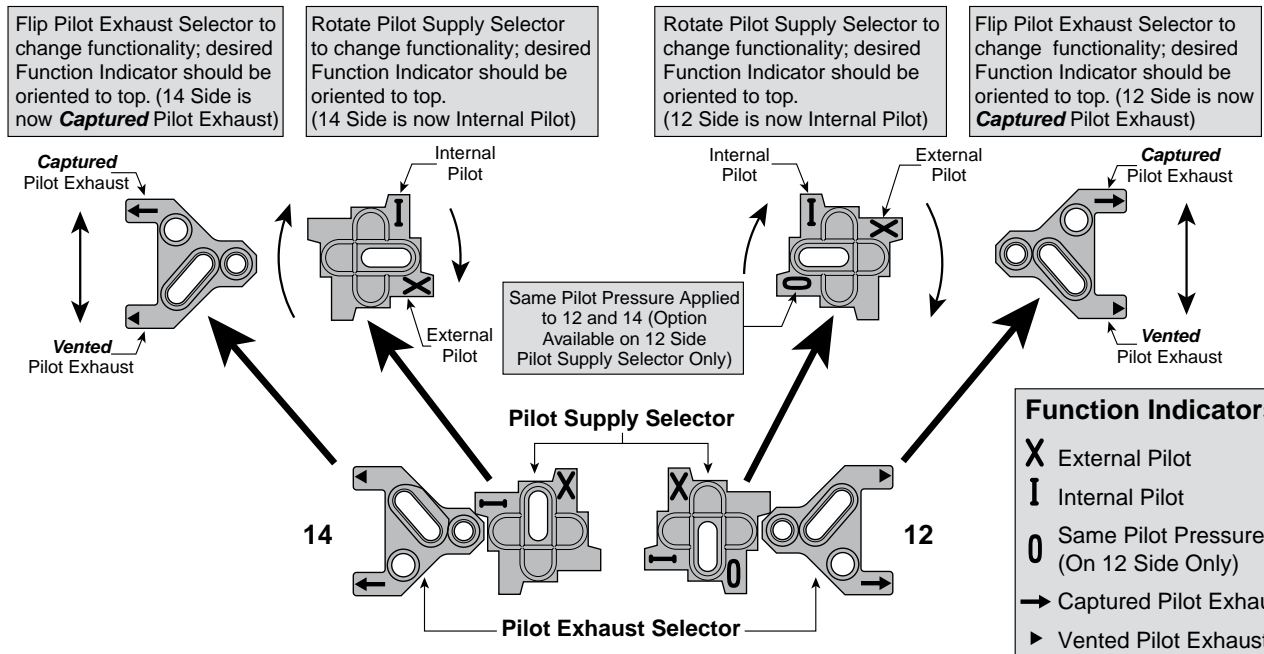



<p>Internal Pilot Supply; Captured Pilot Exhaust through 12</p> <p>14 A 12</p>					<p>External Pilot Supply on 14; Internal Pilot Supply on 12; Vented Pilot Exhaust</p> <p>14 D 12</p>		
<p>External or Single Remote Pilot Supply on 14; Internal Pilot Supply on 12; Captured Pilot Exhaust through 12</p> <p>14 B 12</p>					<p>External Pilot Supply 14 Common to 12; Captured Pilot Exhaust through 12</p> <p>14 E 12</p>		
<p>External, Double Remote Pilot Supply on 14 & 12; Captured Pilot Exhaust</p> <p>14 C 12</p>					<p>Internal Pilot Supply on 14; External Pilot Supply on 12; Vented Pilot Exhaust</p> <p>14 F 12</p>		
<p>Internal Pilot Supply; Vented Pilot Exhaust</p> <p>14 G 12</p>							
Base Pilot Port Used	None	14	14 and 12	None	14	14	12
Pilot Air Supply	Internal Pilot Supply	14 External Pilot 12 Internal Pilot	External, Double Remote Pilot for 14 and 12	Internal Pilot Supply	14 External Pilot 12 Internal Pilot	One Common External Pilot Pressure for 14 and 12	14 Internal Pilot 12 External Pilot
Pilot Exhaust	Captured	Captured	Captured	Vented	Vented	Captured	Vented
5/2 Double Solenoid	606 A	—	406 C	604 G	D	E	F
5/2 Single Solenoid, Spring Return	621 A	421 B	C	620 G	D	E	F
5/2 Single Solenoid, Differential Return	651 A	451 B	C	65 G	D	E	F
5/3 Pressure Center Exhaust	611 A	—	411 C	627 G	D	E	F
5/3 Pressure All Ports Blocked	616 A	—	416 C	625 G	D	E	F
Part Numbers Available From Factory					See Gasket Configurations Above for These Special Adaptations		

F

Insert a muffler or vent in the EXH Port of the PEJ02 & PEJ01 Manifold End Plates or #12 of PL02 & PL01 Subbases when using solenoids with a **Captured** Exhaust.

A plug may be inserted in the EXH Port of the PEJ02 & PEJ01 Manifold End Plates #14 or #12 of PL02 & PL01 Subbases when using a **Vented** Exhaust.





Manifold Assembly

Ports

- 1 Pressure
- 2 #2 Cylinder Port, 1 to 2 Flow Path
- 3 Cylinder Exhaust Port, 2 to 3 Flow Path
- 4 #4 Cylinder Port, 1 to 4 Flow Path
- 5 Cylinder Exhaust Port, 4 to 5 Flow Path
- 14 #14 Pilot Port
- 12 #12 Pilot Port

Torque Specifications: 25 to 35 in-lbs (2.82 to 3.95 Nm)

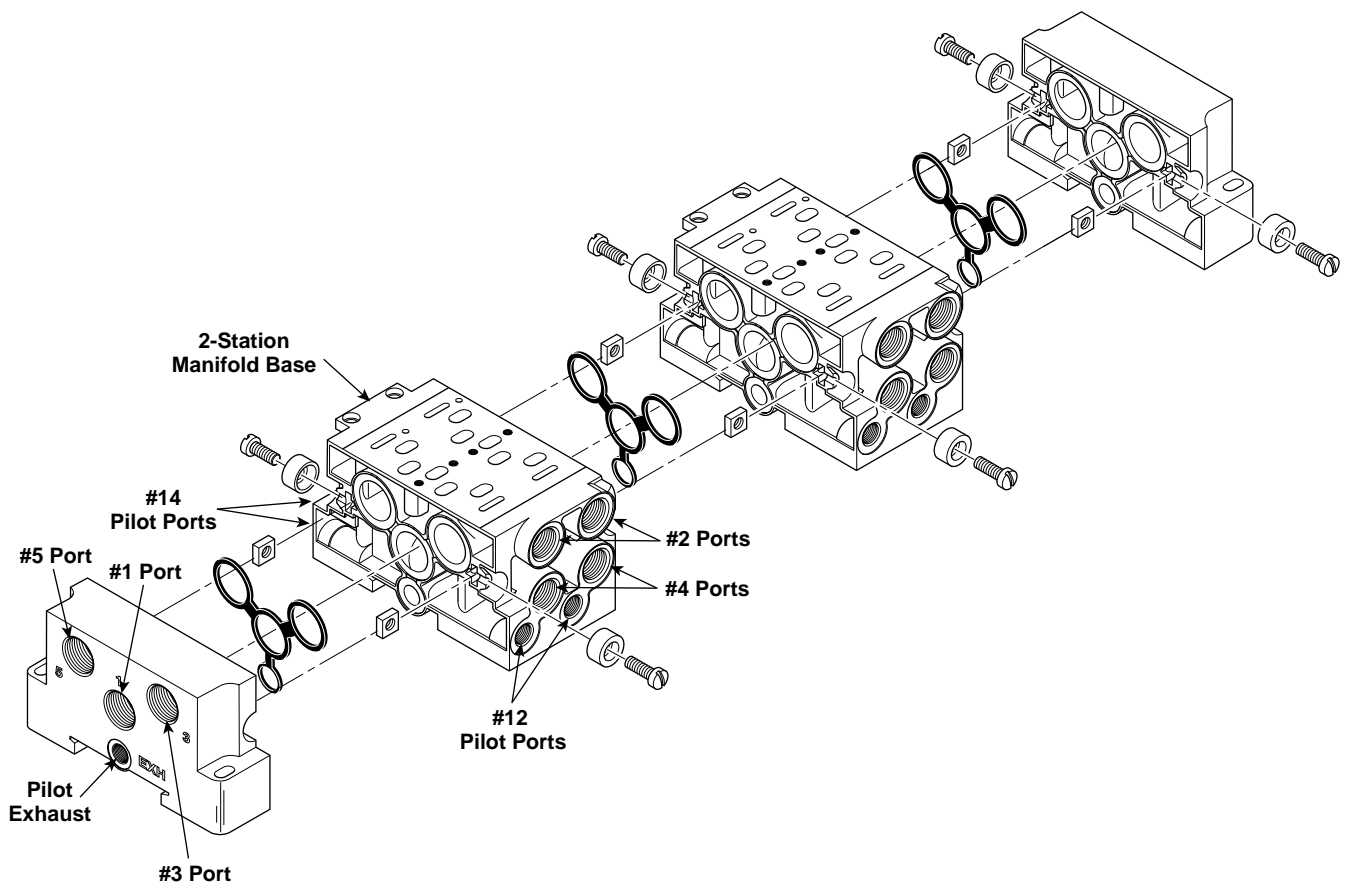

DX01 Shown





Captured Pilot Exhaust

PJL01, Size 01

A Built-in 2-Position Selector converts the External Pilot Channel (12) into a Common Solenoid Pilot Exhaust Channel.

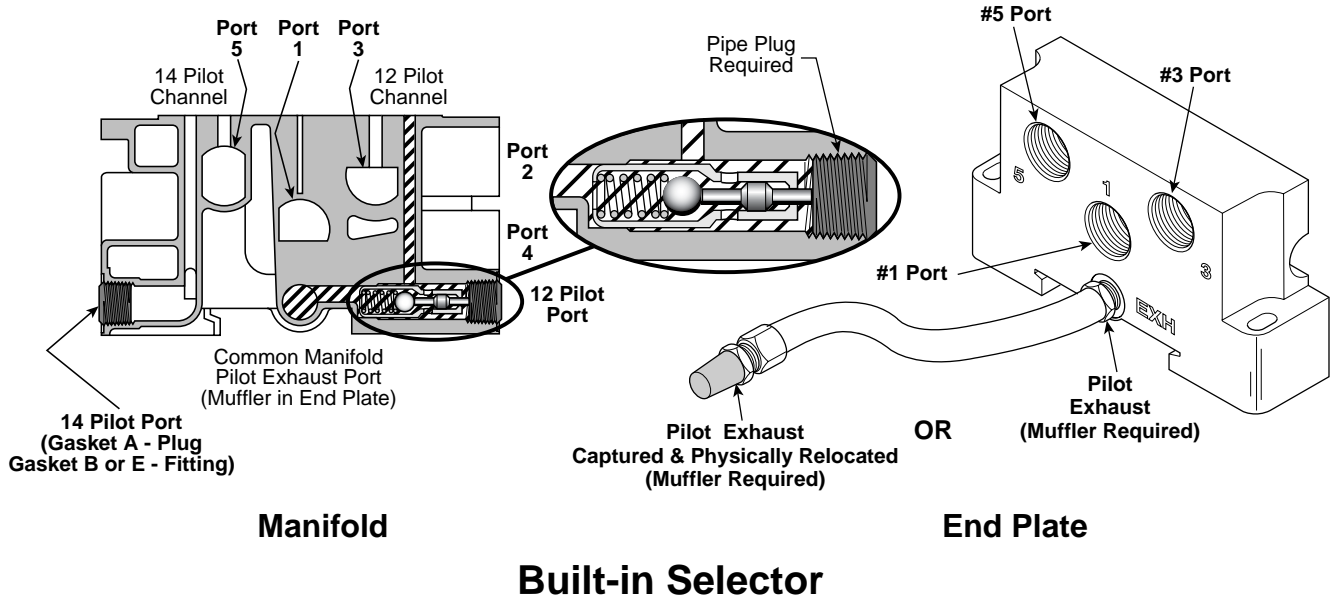

When using A, B or E **Captured** Selector Gasket Positions, the 12 Pilot Port is plugged. The 14 Pilot Port has a plug when using Gasket A or a fitting when using Gasket B or E. When in place, the Plug in the 12 Pilot Port depresses the Selector to connect the Valve Solenoid Pilot Exhaust to a Common Manifold Exhaust Port. The Plug **must** make contact with the Pin of the Internal Check Valve.

Insert a Muffler in the EXH Port of the End Plate.

Captured Selector Gasket Positions

When using A, B or E Selector Gasket Positions as shown in the schematic at right.

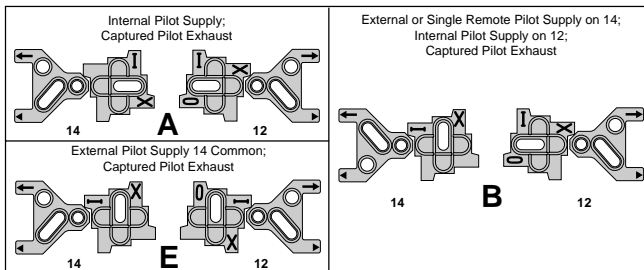

Insert a muffler or vent in the EXH Port of the PEJ02 & PEJ01 Manifold End Plates or #12 of PL02 & PL01 Subbases when using solenoids with **Captured** Pilot Exhaust.

DX01 Manifold Assembly Schematic for Captured Selector Gasket Positions A, B and E

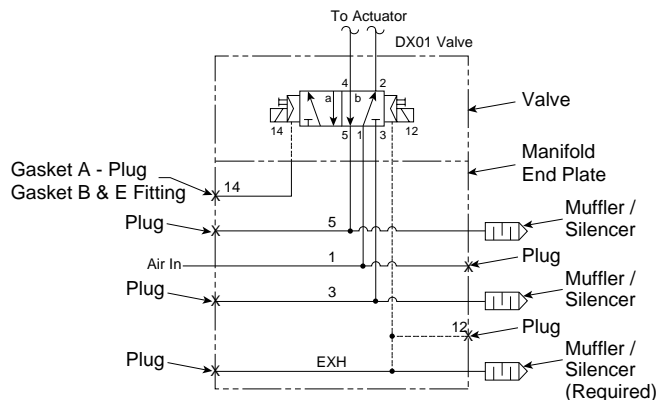

F



Vented Pilot Exhaust

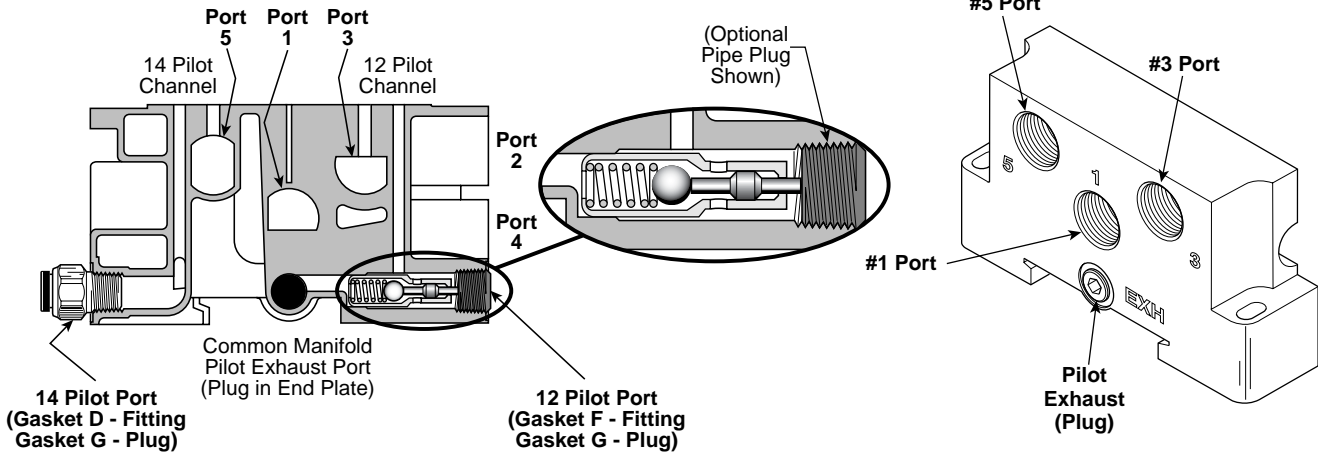

Manifold

End Plate

Built-in Selector

When using D or G **Vented** Selector Gasket Positions, the 12 Pilot Port may be plugged (Optional). The 14 Pilot Port has a plug when using Gasket G or a fitting when using Gasket D or F. The valve solenoid pilot exhaust vents out the pilot adapter on the G Gasket Selection.

Vented Selector Gasket Positions

When using D, F or G Selector Gasket Positions, pilot exhaust air is vented out the valve.

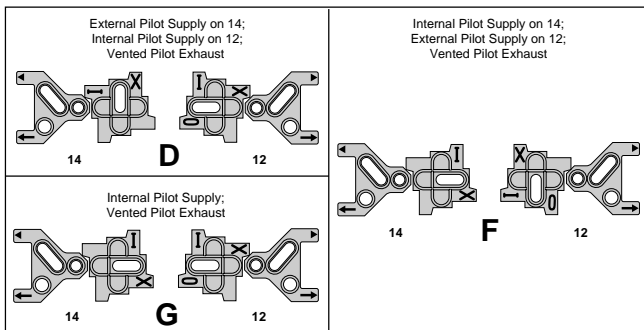

A plug may be inserted in the EXH Port of the PEJ02 & PEJ01 Manifold End Plates, #12 of PL02 & PL01 Subbases.

DX01 Manifold Assembly Schematic for Vented Selector Gasket Positions D or G

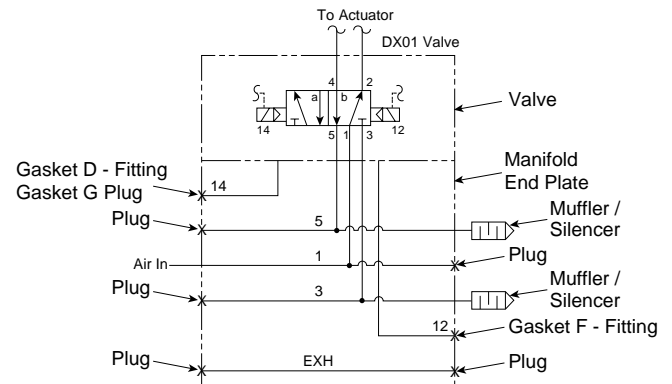



External Double Remote Pilot

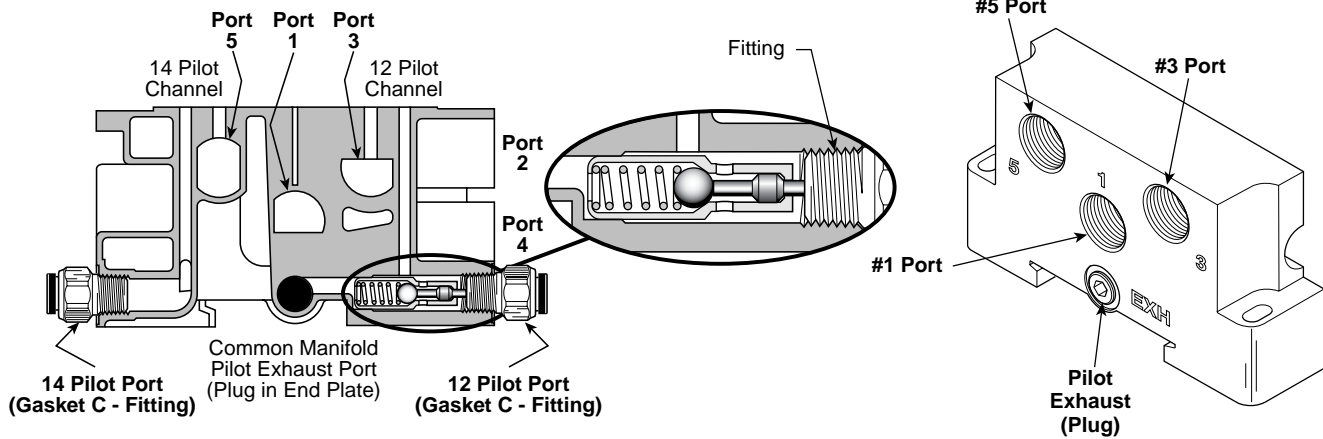

Built-in Selector

When using C **External Double Remote Pilot** Selector Gasket Position, a fitting is used in Pilot Port 14 & 12. Free flow between Port 14 & 12 and the valve allows Remote Pilot Pressure and an exhaust path for the captured pilot exhaust.

External Double Remote Pilot Selector Gasket Position

When using C Selector Gasket Position.

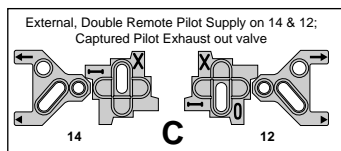

DX01 Manifold Assembly Schematic for External Double Remote Pilot Selector Gasket Position C

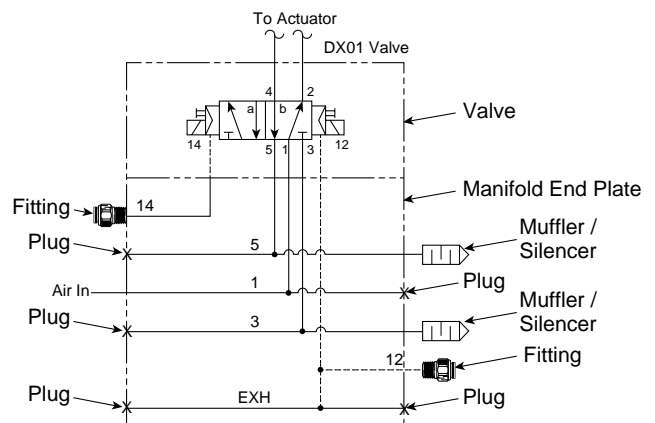

F



Manifold Assembly

Ports

- 1..... Pressure
- 2..... #2 Cylinder Port, 1 to 2 Flow Path
- 3..... Cylinder Exhaust Port, 2 to 3 Flow Path
- 4..... #4 Cylinder Port, 1 to 4 Flow Path
- 5..... Cylinder Exhaust Port, 4 to 5 Flow Path
- 14..... #14 Pilot Port
- 12..... #12 Pilot Port

Torque Specifications: 25 to 35 in-lbs (2.82 to 3.95 Nm)

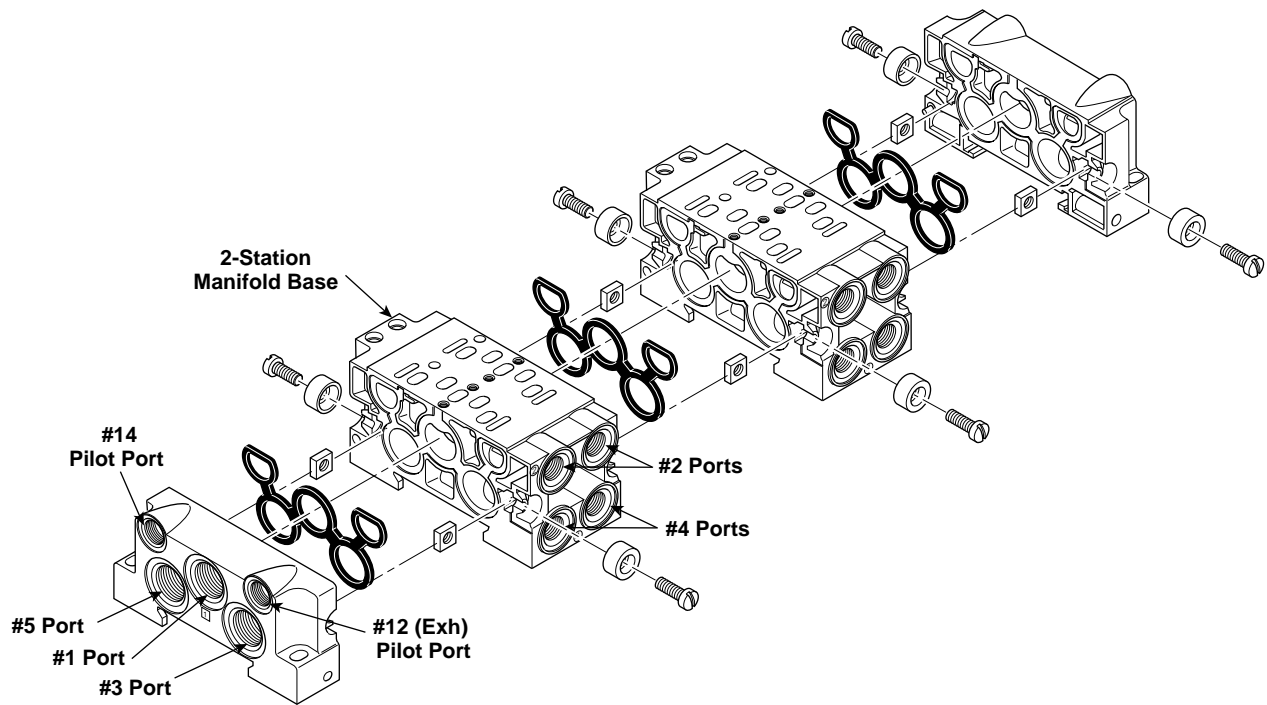

DX02 Shown





Captured Pilot Exhaust

PJLP02, Size 02*

As shown in the illustrations below, the EXH (12) & 14 Pilot Ports are exhausted internally in the valve body into a single chamber labeled EXH on the end plate. When using A, B, D or E Selector Gasket Positions, the EXH (12) Pilot Port is vented with a muffler or micron screen. The 14 Pilot Port is plugged.

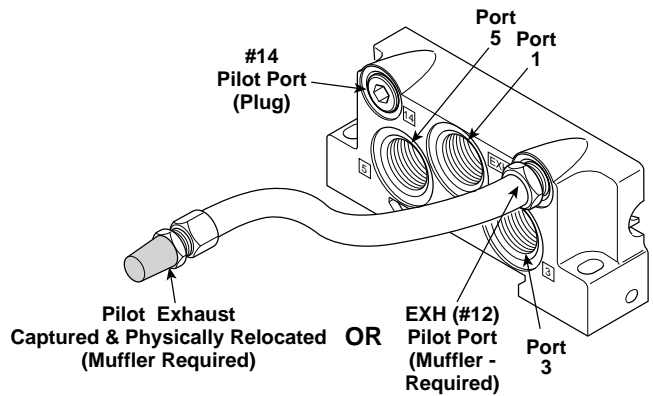
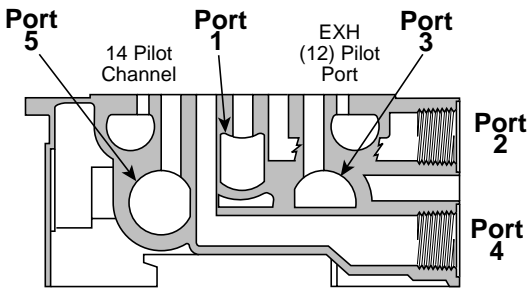

Captured Selector Gasket Positions

When using A, B, D or E, Selector Gasket Positions, the ports must be either plugged or vented with a muffler or micron screen as shown in the schematic at right.

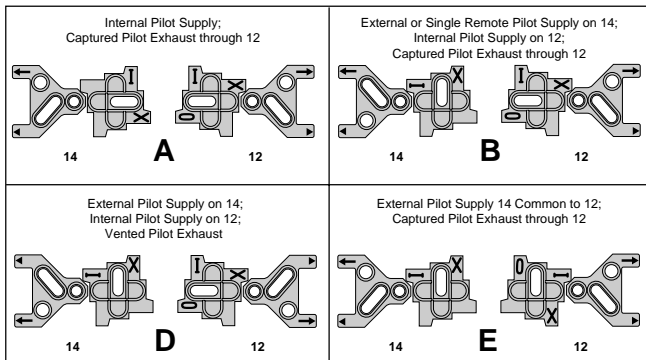

* PJLP02 Manifolds can be used for External Pilot, **NOT** Remote Pilot

DX02 Manifold Assembly Schematic for Captured Selector Gasket Positions A, B, D and E

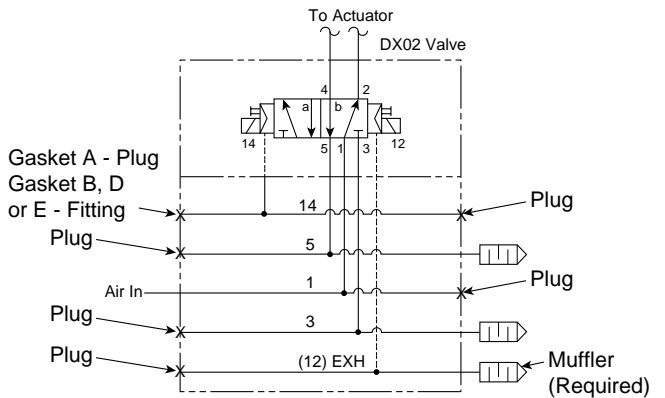

F



Vented Pilot Exhaust

PJLP02, Size 02
 When using F or G Selector Gasket Positions, the EXH (12) Pilot Port and the 14 Pilot Port are plugged and the Pilot Exhaust is vented through the Pilot Adapter.

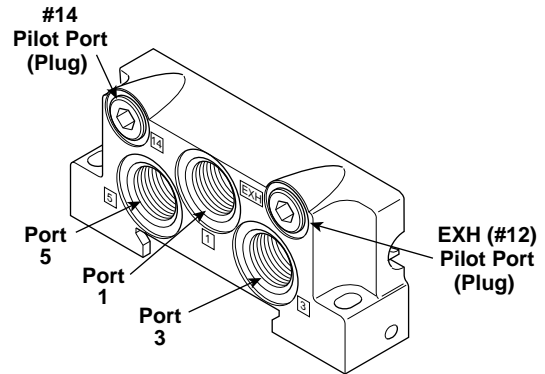
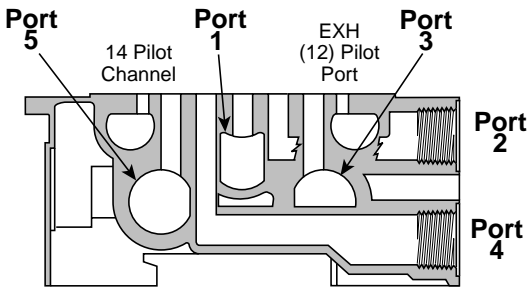

Vented Selector Gasket Positions

When using F or G, Selector Gasket Positions, the ports must be either plugged or vented with a muffler or micron screen as shown in the schematic at right.

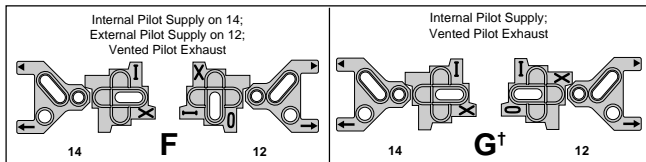

† A plug may be inserted in the EXH Port of the PEJ02 & PEJ01 Manifold End Plates or #12 of PL02 & PL01 Subbases.

DX02 Manifold Assembly Schematic for Vented Selector Gasket Positions F and G

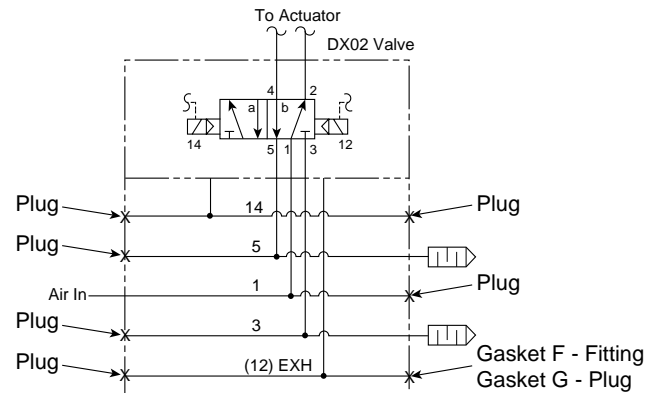



Subbase Assembly

Ports

- 1.....Pressure
- 2.....#2 Cylinder Port. 1 to 2 Flow Path.
- 3.....Cylinder Exhaust Port. 2 to 3 Flow Path.
- 4.....#4 Cylinder Port. 1 to 4 Flow Path.
- 5.....Cylinder Exhaust Port. 4 to 5 Flow Path.
- 14.....#14 Pilot Port
- 12.....#12 Pilot Port

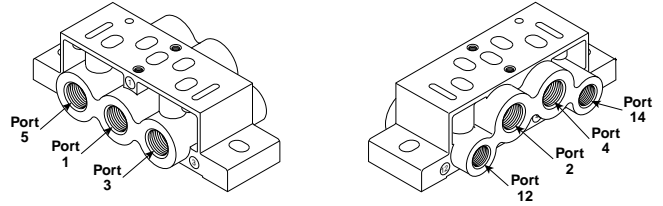

Captured Selector Gasket Positions

When using A, B, C, D or E, Selector Gasket Positions, the ports must be either plugged or vented with a muffler or micron screen as shown in the schematic at right.

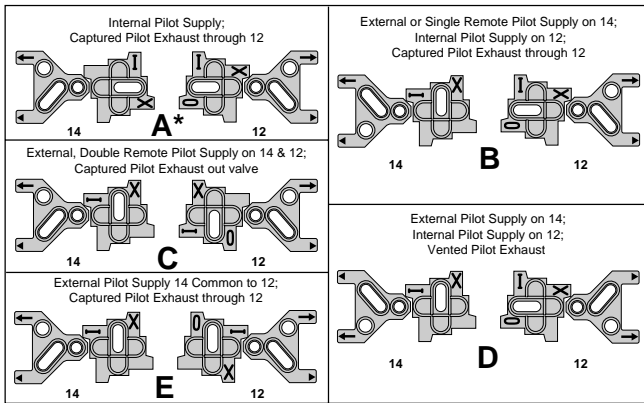

DX02 & DX01 Subbase Assembly Schematic for Captured Selector Gasket Positions A, B, C, D and E

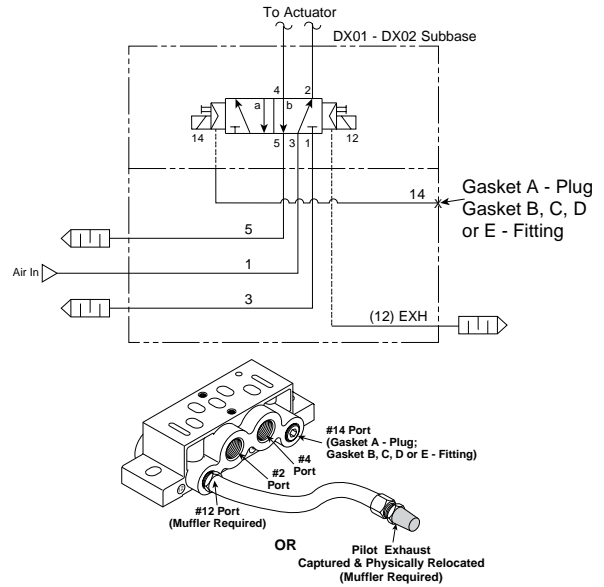

Vented Selector Gasket Positions

When using F or G, Selector Gasket Positions, the ports must be either plugged or vented with a muffler or micron screen as shown in the schematic at right.

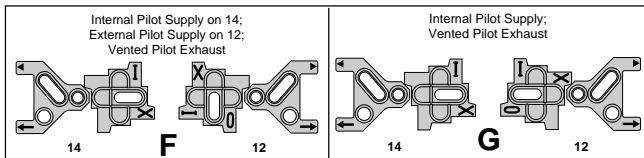

DX02 & DX01 Subbase Assembly Schematic for Vented Selector Gasket Positions F and G

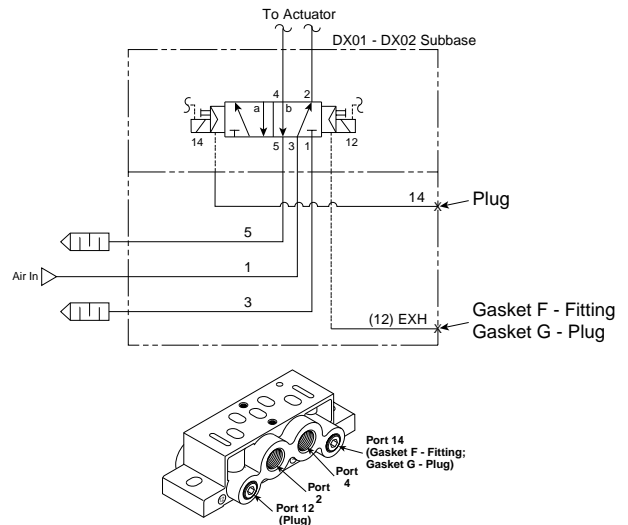

F



DX02

Valves

DX01

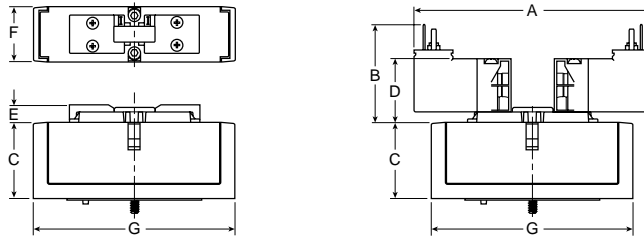

Series	A	B	C	D	E	F	G
DX02	4.06 (103)	1.61 (41)	1.41 (36)	1.06 (27)	.31 (8)	.71 (18)	3.15 (80)
DX01	4.06 (103)	1.61 (41)	1.41 (36)	1.06 (27)	.31 (8)	1.02 (26)	3.94 (100)

Inches
(mm)

DX02

Individual Subbase

DX01

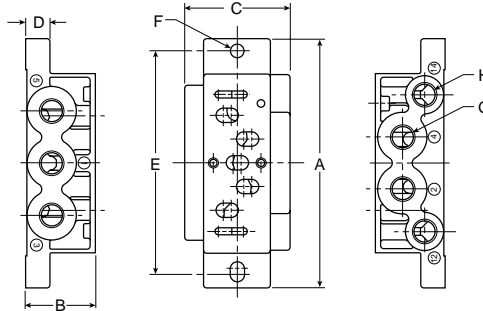

Series	Part Number	A	B	C	D	E	F	G	H
DX02	PL02	3.15 (80)	.87 (22)	1.06 (27)	.31 (8)	2.76 (70)	.216 Dia. (Ø 5.5)	1/8	M5
DX01	PL01	3.94 (100)	1.10 (28)	1.65 (42)	.39 (10)	3.54 (90)	.216 Dia. (Ø 5.5)	1/4	1/8

Inches
(mm)

DX02

2-Station Manifold Bases

DX01

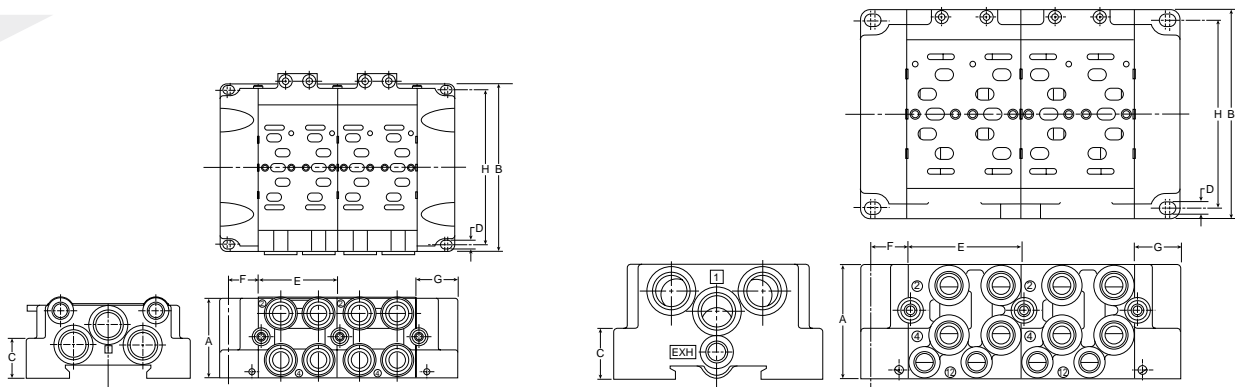

Series	Part Number	A	B	C	D	E	F	G	H
DX02	PJLP02 / PEJ02	1.52 (38.5)	3.15 (80)	.47 (12)	.165 Dia. (Ø 4.2)	1.50 (38)	.55 (14)	.71 (18)	2.83 (72)
DX01	PJL01 / PJLP01 / PEJ01	2.17 (55)	3.94 (100)	.94 (24)	.216 Dia. (Ø 5.5)	2.13 (54)	.67 (17)	.87 (22)	3.54 (90)

Inches
(mm)





DX01

DX01 15407-1, PS5511 Subbases

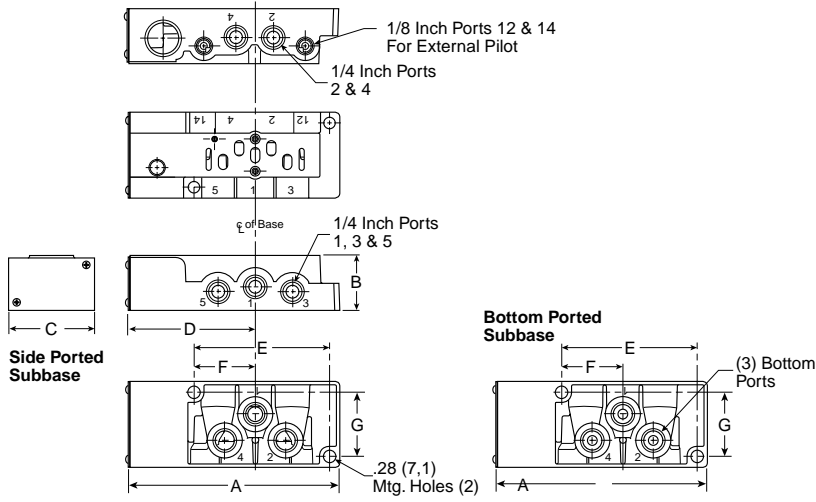

A 4.88 (124)	B 1.28 (32.5)	C 2.00 (50.8)	D 2.91 (74)
E 1.43 (36.2)	F 3.16 (80.2)	G 1.49 (37.9)	

Inches (mm)

DX02

DX02 & DX01 15407-1, PS5611 & PS5511 Manifolds

DX01

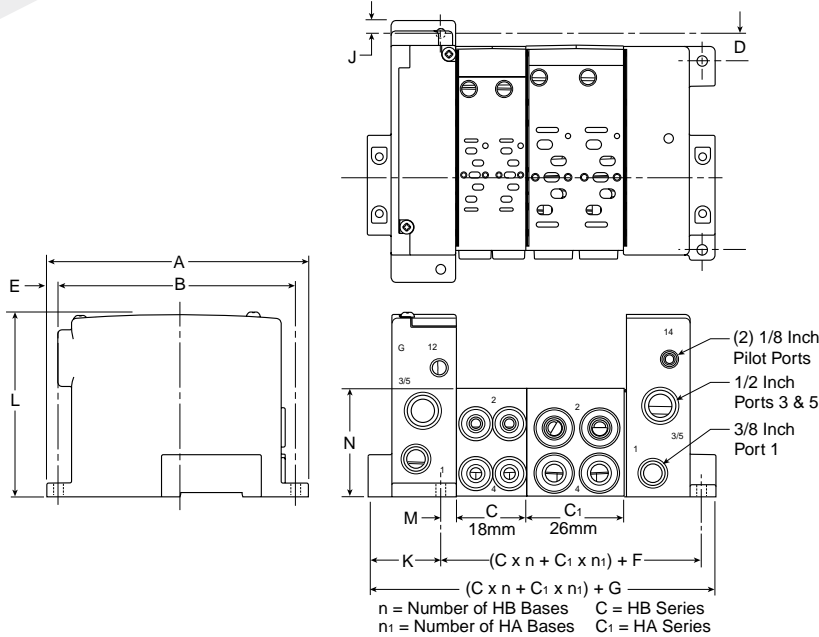

A 5.98 (152)	B 5.39 (137)	C 1.61 (40.8)	C₁ 2.24 (56.8)
D .63 (16)	E .30 (7.5)	F 2.14 (54.4)	G 4.12 (104.6)
H 4.32 (109.8)	J .15 (4)	K 1.68 (42.7)	L 4.17 (106)

Inches (mm)

DX01

DX02

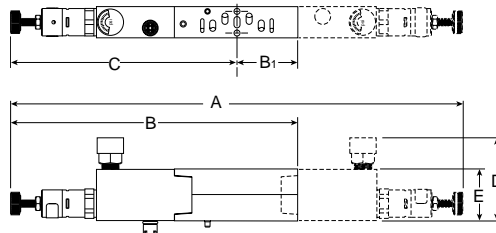

Series	Part Number	A	B	B ₁	C	D	E
DX02	PS5637	10.28 (261)	6.14 (156)	1.02 (26)	5.13 (130)	2.60 (66)	1.18 (30)
DX01	PS5537	10.02 (255)	6.43 (163)	1.41 (36)	5.02 (127)	2.00 (51)	1.18 (30)

Inches
(mm)

F





ISOMAX 5599-1



Ceramic Technology / Valve Specifications

- Subbase Mounted Valves Conforming to ISO Standard 5599/1
- High Flow: DX1 (1.15 Cv), DX2 (2.50 Cv), DX3 (4.15 Cv)
- Air or Solenoid Operation Using CNOMO Solenoids
- Can Be Vacuum Operated

Air Condition:

Filtered to 40µ

Dual Pressure Supply from Exhaust Ports:

Yes - Without additional pressure at 12 and 14

Dust and Water Protection:

IP 65 (According to EN 60529)

Mechanical Life:

> 100 million operations (Dry air filtered 40 µ, 2 Hz, 6 bar, 20°C)

Media:

Air or inert gas, filtered 40 µ (Class 5 according to ISO 8573-1), lubricated or non-lubricated

Operating Temperature Range:

-10°C to 60°C (14°F to 140°F)

Flow Rating (Cv)

Size	Port Size	Mounting Style	2-Position	3-Position
DX1	1/4" Ports	Subbase	1.15	0.75
	1/4" Ports	Manifold	0.80	0.60
DX2	3/8" Ports	Subbase	2.50	2.40
	3/8" Ports	Manifold	2.05	1.95
DX3	1/2" Ports	Subbase	4.15	4.00
	1/2" Ports	Manifold	4.10	3.65

Cv tested per ANSI / (NFPA) T3.21.3

Flow Rating (Cv) with Sandwich Regulator

	Common Pressure				Dual Pressure			
	1-2	1-4	2-3	4-5	1-2	1-4	2-3	4-5
DX1	0.55	0.49	1.06	1.02	0.32	0.42	0.25	0.38
DX2	1.06	1.05	2.33	2.17	0.93	0.66	0.77	1.15

Note: All Cv's calculated with regulator adjusted full open.

Response Time** Single Solenoid 2-Position - Air Return / Spring Assist

Valve Size	Port Size	0 Cu. In. Chamber		## Cu. In. Chamber	
		Fill	Exhaust	Fill	Exhaust
DX1	1/4"	.025	.030	.160	.235
DX2	3/8"	.040	.045	.170	.235
DX3	1/2"	.060	.065	.245	.330

DX1 (50), DX2 (100), DX3 (200)

** With 100 PSIG supply, time required to fill from 0 to 90 PSIG and Exhaust from 100 PSIG to 10 PSIG measured from the instant of energizing or de-energizing 24VDC solenoid.

Tested per ANSI / (NFPA) T3.21.8

Solenoid Information

Code	Voltage			Power (W / VA)
	AC		DC	
	60Hz	50Hz		
19	—	—	24	2.8W
49	—	—	24	2.7W
53	120	115	—	3.7VA

Data tested with LED and Surge Suppression.

Operating Pressure

Vacuum to 145 PSIG (10 bar)

Function		M.O.P. (PSIG)		
Internal Pilot		DX1	DX2	DX3
21	2-Position, Spring Return	36	30	30
51	2-Position, Air Return	30	30	30
06	2-Position	15	15	15
11	3-Position, CE	45	36	36
16	3-Position, APB	45	36	36
13	3-Position, PC	45	36	36
External Pilot		DX1	DX2	DX3
22	2-Position, Spring Return	36	30	30
53	2-Position, Air Return	30	30	30
08	2-Position	15	15	15
12	3-Position, CE	45	36	36
18	3-Position, APB	45	36	36
24	3-Position, PC	45	36	36

Material Specification

Body Polyamide Reinforced Fiberglass
 Casing - End Plates Anodized Aluminium
 Seals Nitrile
 Screws Zinc Plated Steel
 Valve Member / Seat Self Lubricating / Ceramic
 Valve Plate Zinc





Single Solenoid

2-Position



DX1 Shown

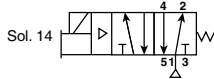

DX1	DX1-621-BL53	120VAC	1.15 Cv
	DX1-621-BL49	24VDC	
DX2	DX2-621-BL53	120VAC	2.50 Cv
	DX2-621-BL49	24VDC	
DX3	DX3-621-BL53	120VAC	4.15 Cv
	DX3-621-BL49	24VDC	

30mm 3-Pin Solenoid, NLMOR, Unlighted, Internal Pilot, Valve Less Base

Double Solenoid

2-Position

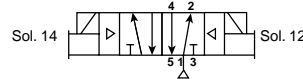
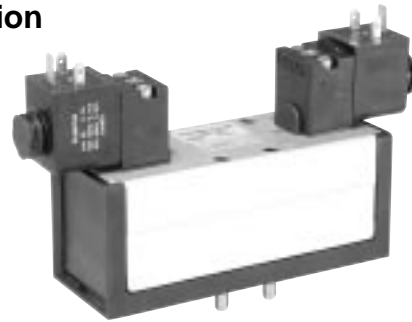

DX1	DX1-606-BL53	120VAC	1.15 Cv
	DX1-606-BL49	24VDC	
DX2	DX2-606-BL53	120VAC	2.50 Cv
	DX2-606-BL49	24VDC	
DX3	DX3-606-BL53	120VAC	4.15 Cv
	DX3-606-BL49	24VDC	

30mm 3-Pin Solenoid, NLMOR, Unlighted, Internal Pilot, Valve Less Base

Double Solenoid

3-Position APB

3-Position CE

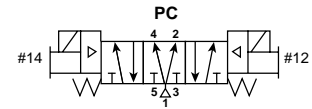
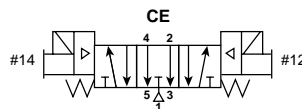
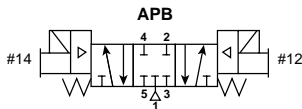

	APB			CE			PC		
DX1	DX1-616-BL53	120VAC	.75 Cv	DX1-611-BL53	120VAC	.75 Cv	DX1-613-BL53	120VAC	.75 Cv
	DX1-616-BL49	24VDC		DX1-611-BL49	24VDC		DX1-613-BL49	24VDC	
DX2	DX2-616-BL53	120VAC	2.40 Cv	DX2-611-BL53	120VAC	2.40 Cv	DX2-613-BL53	120VAC	2.40 Cv
	DX2-616-BL49	24VDC		DX2-611-BL49	24VDC		DX2-613-BL49	24VDC	
DX3	DX3-616-BL53	120VAC	4.00 Cv	DX3-611-BL53	120VAC	4.00 Cv			
	DX3-616-BL49	24VDC		DX3-611-BL49	24VDC				

30mm 3-Pin Solenoid, NLMOR, Unlighted, Internal Pilot, Valve Less Base.

Torque Specifications

DX1: 25 to 35 in-lbs (2.82 to 3.95 Nm)

DX2: 115 to 130 in-lbs (12.99 to 14.69 Nm)

DX3: 120 to 1430 in-lbs (13.56 to 15.82 Nm)

For Compact and VDMA Subbase and Manifold, see page F31.

For Hi-Flow Subbases and Manifolds, see page F32.



BOLD OPTIONS ARE MOST POPULAR

DX1 - 6 06 - B L 53

Basic Series	
ISO 5599-1	DX1 - Size 1
ISO 5599-1	DX2 - Size 2
ISO 5599-1	DX3 - Size 3

Pilot	
Air Operated Remote Pilot	4
Solenoid Operated	6

Function	
Internal Pilot Supply	
2-Position, Spring Return	21**
2-Position, Diff Return	51
2-Position	06
3-Position, CE	11
3-Position, APB	16
3-Position, PC	13*
External Pilot Supply†	
2-Position, Spring Return	22
2-Position, Diff Return	53
2-Position	08
3-Position, CE	12
3-Position, APB	18
3-Position, PC	24*

* Not offered with DX3 Valves.
 ** Spring Return versions are air assisted.
 † Must be specified when using Sandwich Regulators.

Voltage & Frequency		
	AC	DC
	60Hz	50Hz
19*		24
49		24
53	120	110
Blank	Remote Pilot or Valve Less Coil	

* LED & Surge Suppression.
 Only Available with Enclosure "6".

5599-1 Enclosure / Lead Length	
0**	None, Remote Pilot Valve
6*	2-Pin, M12 EURO Connector with CNOMO Operator
L	3-Pin, 30mm DIN 43650A with CNOMO Connector
P	3-Pin, 22mm Industrial with CNOMO Connector
N†	None, Valve Less Coil

* Only available with Overrides / Lights Option "G" & "H" with Enclosure / Lead Length Option "6".
 ** Must use Overrides / Lights Option "6" or "7".
 † Must use Overrides / Lights Option "B" or "C".

5599-1 Overrides / Lights	
6	Remote Pilot / Without Solenoid
7*	Remote Pilot / Without Solenoid
B	Non-Locking, Flush, Push - w/o Light
C	Locking, Flush, Push / Turn - w/o Light
G**	Non-Locking, Flush, Push - w/ Light
H**	Locking, Flush, Push / Turn - w/ Light

* Direct Manual Override
 ** Apply to Voltage Code "19" & Enclosure / Lead Length "6"



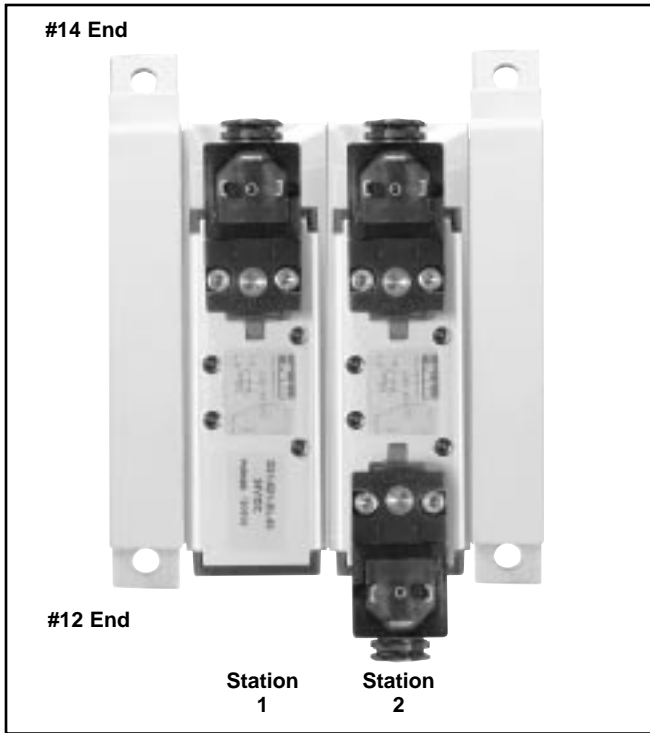

How To Order Add-A-Fold Assemblies

1. List Add-A-Fold Assembly call out. This automatically includes the end plate kit assembly.
2. List complete valve/base model number. List left to right, **LOOKING AT THE CYLINDER PORTS** on the #12 end of the manifold. The left most station is station 1.

(If a blank station is needed, list the blanking plate part number and the individual manifold number in the station specified.)

Model Number

AA	H1	S	0	03	—
-----------	-----------	----------	----------	-----------	----------

Valve Series	
DX1, ISO Size 1	H1
DX2, ISO Size 2	H2
DX3, ISO Size 3	H3

End Plate Type	
Standard Non-Collective Wiring	S
VDMA, 5599-1	V

Port Type	
NPT	0
BSPP "G"	1

Transition Plate	
Blank	No Transition Plate
C*	DX1 to DX2
D*	DX1 to DX3
E**	DX2 to DX3

Number of Stations	
01	1 Station
•	•
•	•
•	•
21	21 Stations

* Use DX1 Valve Series.
** Use DX3 Valve Series.



Example: Application requires a 2-Station manifold.

Qty.	Part No.
1	AAH2S002
1	DX2-621-BL49..... Valve Station 1
1	PS4111570CP.....Base Station 1
1	DX2-606-BL49 Valve Station 2
1	PS4111570CP.....Base Station 2



5599-1 Compact Manifolds, Subbases & Accessories

Manifold VDMA – Form C Bottom Port

Size	Port Size	Kit Number
		BSPG “G”
DX1	1/4"	P2N-VM512MB
DX2	3/8"	P2N-WM513MB
DX3	1/2"	P2N-YM514MB



VDMA End Plates – Form D

Size	Port Size	Kit Number
		BSPG “G”
DX1	3/8"	P2N-VM513ES
DX2	1/2"	P2N-WM514ES
DX3	1"	P2N-YM518ES



Subbase – Side Ports (5599-1 & VDMA)

Size	Port Size	5599-1 Kit Number		VDMA Kit
		NPT	BSPG “G”	BSPG “G”
DX1	1/4"	PL1-1/4-80	PL1-1/4-70	P2N-VS512SD
DX2	3/8"	PL2-3/8-80	PL2-3/8-70	P2N-WS513SD
DX3	1/2"	PL3-1/2-80	PL3-1/2-70	P2N-YS514SD



Subbase – Bottom Ports

Size	Port Size	5599-1 Kit Number	
		NPT	BSPG “G”
DX1	1/4"	PD1-1/4-80	PD1-1/4-70
DX2	3/8"	PD2-3/8-80	PD2-3/8-70

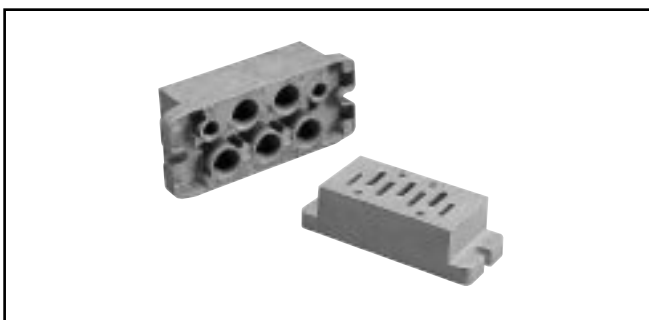

VDMA Transition Plate

Kit Number
P2N-VM500AK

Kit includes: Transition Plate Only. Order P2N-VM513ES and P2N-YM518ES Separately to Assemble Add-A-Fold

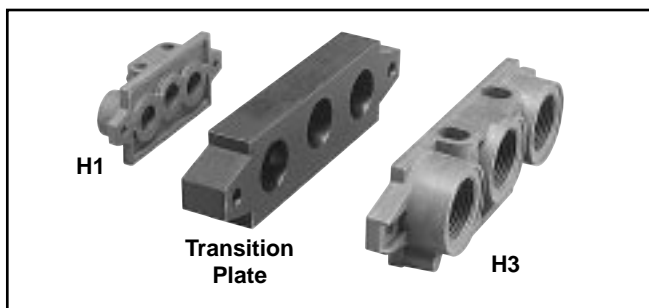



5599-1, DX1, DX2 & DX3 Hi-Flow Manifold / Subbase Kits

PS4011 55 0 C P

Basic Series	
DX1	PS4011
DX2	PS4111
DX3	PS4211

Enclosures / Lead Length	
0	None, No Electrical Plug - 5599-1

Mounting Base Style / Port Size					
DX1 Series		DX2 Series		DX3 Series	
Subbase: 3/8 NPT Side Ports	15	Subbase: 1/2 NPT Side Ports	17	Subbase: 3/4 NPT Side Ports	19
Subbase: 3/8 BSPP Side Ports	16*	Subbase: 1/2 BSPP Side Ports	18*	Subbase: 3/4 BSPP Side Port	10*
Manifold: 1/4 NPT End Ports	53	Subbase: 1/2 NPT Bottom / End Port	27	Subbase: 3/4 NPT Bottom / End Port	29
Manifold: 1/4 BSPP End Ports	54*	Subbase: 1/2 BSPP Bottom / End Port	28*	Subbase: 3/4 BSPP Bottom / End Port	20*
Manifold: 3/8 NPT End Ports	55	Manifold: 3/8 NPT End Ports	55	Manifold: 1/2 NPT End Port	57
Manifold: 3/8 BSPP End Ports	56*	Manifold: 3/8 BSPP End Ports	56*	Manifold: 1/2 BSPP End Ports	58*
Manifold: 3/8 NPT Bottom / End Port	65†	Manifold: 1/2 NPT End Port	57	Manifold: 3/4 NPT End Port	59
Manifold: 3/8 BSPP Bottom / End Port	66*†	Manifold: 1/2 BSPP End Ports	58*	Manifold: 3/4 BSPP End Port	50
		Manifold: 1/2 NPT Bottom / End Port	67	Manifold: 3/4 NPT Bottom / End Port	69
		Manifold: 1/2 BSPP Bottom / End Port	68*	Manifold: 3/4 NPT Bottom / End Port	60*

*BSPP ISO 1179 Specifications.
 †#1 Bottom Port - 1/4".

Subbase Kits

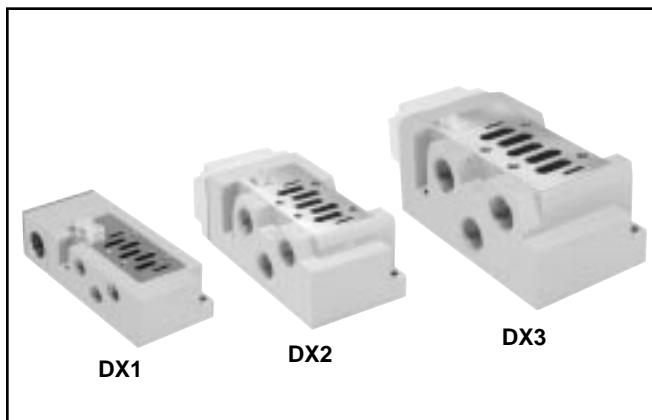

Manifold Kits

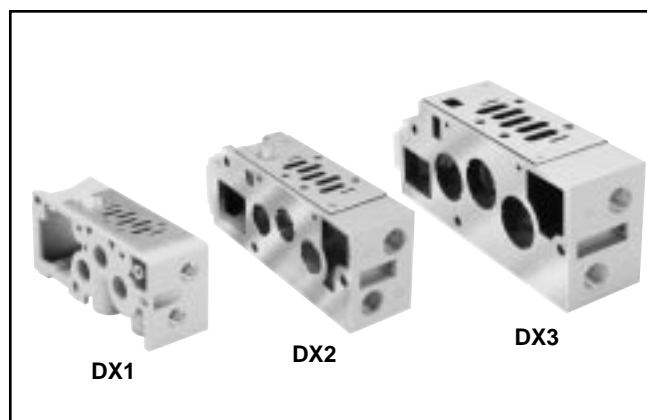

F



5599-1, DX1, DX2 & DX3 End Plate Kits

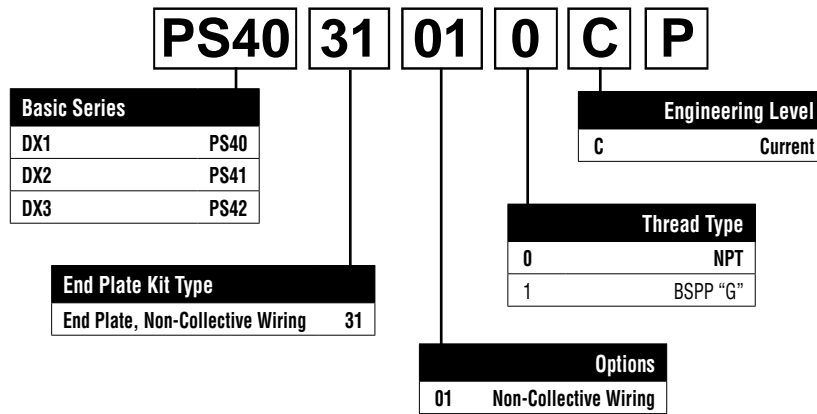

DX1 Non-Collective Wiring
 End Plates

5599-1, DX1, DX2 & DX3 Transition Plate Kits

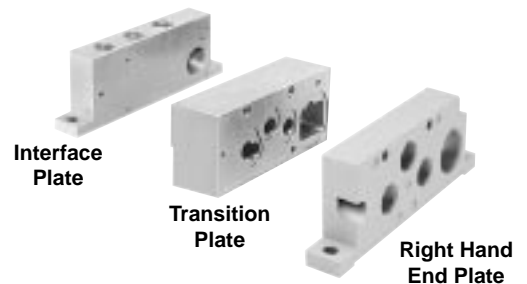
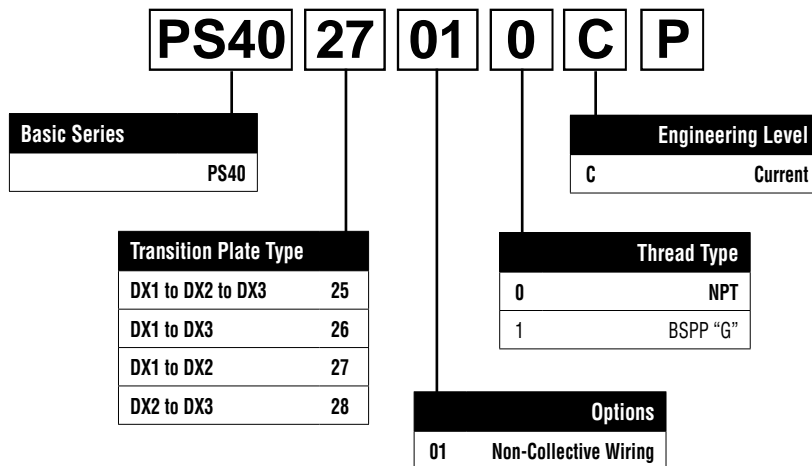

DX1 to DX2 Shown





Blanking Plate Kits

Size	Kit Number	
	5599-1	VDMA
DX1	PS4034CP	P2N-AA5B
DX2	PS4134CP	P2N-BA5B
DX3	PS4234CP	P2N-CA5B

Kit includes: Blanking Plate, Gasket, and Mounting Bolts.



Manifold Port Isolation Kits Main Galley (1, 3, 5)

Size	Kit Number	
	5599-1	VDMA
DX1	PS4032CP	P2N-VK0P
DX2	PS4132CP	P2N-WK0P
DX3	PS4232CP	P2N-YK0P

Kit includes: Plugs with O-rings.

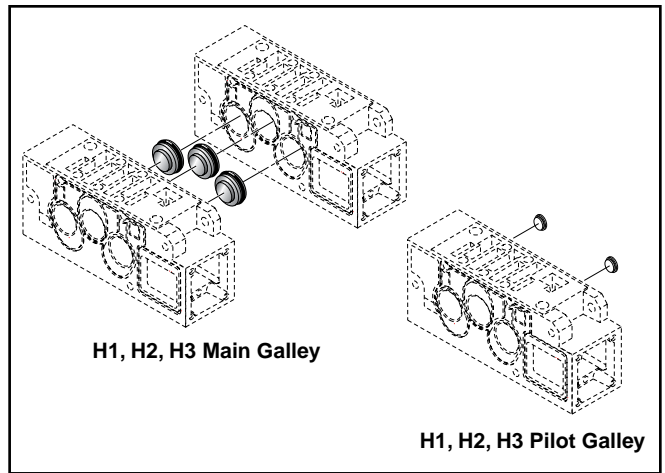

Pilot Galley

Size			Kit Number
DX1	DX2	DX3	PS4033CP

Kit includes: Plugs with O-rings.

Sandwich Flow Controls Features

- Both adjustment screws are located on the 12 end of the unit.
- Sandwich Flow Control mounts with its own studs, which means the valve uses standard bolts for mounting.
- Sandwich Flow Control is not to be used as a shut off device and is not bubble tight when needles are fully turned down.

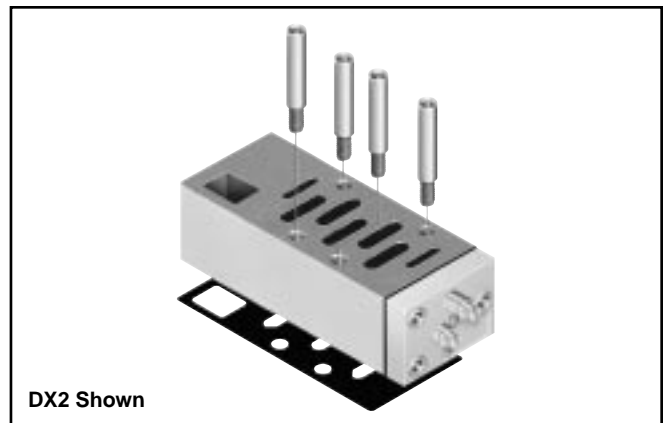

DX2 Shown

Size	Plug-In 5599-2
DX1	PS4042CP
DX2	PS4142CP
DX3	PS4242CP

F



Sandwich Regulators Features

- Remote Air Pilot Operated for hard-to-reach pressure control.
- Unregulated Pilot Pressure to valve for consistent valve shifting regardless of pressure adjustment.

DX1 - Size 1
 (Independent Dual Port Regulator Shown)

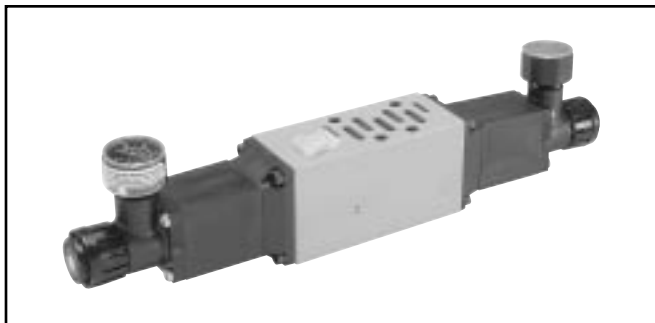

DX2 - Size 2
 (Independent Dual Port Regulator Shown)

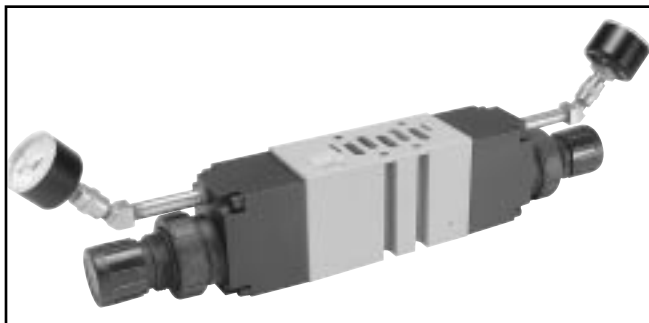

BOLD OPTIONS ARE MOST POPULAR

PS4037 1 6 6 C P

Basic Series	
	DX1
5599-1	PS4037
	DX2
5599-1	PS4137
	DX3
5599-1	PS4237

Regulator Function	
Common Pressure Regulator	1
Independent Pressure Regulator	2
Selector Regulator	3

#2 Port Regulator / Gauge*	
0**	Line By-Pass Plate
1	1-30 PSIG w/o Gauge
2	2-60 PSIG w/o Gauge
3	5-125 PSIG w/o Gauge
4	1-30 PSIG w/Gauge
5	2-60 PSIG w/Gauge
6	5-125 PSIG w/Gauge
C	Air Pilot w/60 PSIG Gauge
D	Air Pilot w/160 PSIG Gauge

* For Common Pressure Regulator Option, Regulator Gauge callout must be the same number for both Port #4 and Port #2. (Example: 166)

** Pressure Line By-Pass Option can only be used with Independent and Selector Regulators (Option 2 & 3 in Sandwich Block Function).

#4 Port Regulator / Gauge*	
0**	Line By-Pass Plate
1	1-30 PSIG w/o Gauge
2	2-60 PSIG w/o Gauge
3	5-125 PSIG w/o Gauge
4	1-30 PSIG w/Gauge
5	2-60 PSIG w/Gauge
6	5-125 PSIG w/Gauge
C	Air Pilot w/60 PSIG Gauge
D	Air Pilot w/160 PSIG Gauge

* For Common Pressure Regulator Option, Regulator Gauge callout must be the same number for both Port #4 and Port #2. (Example: 166)

** Pressure Line By-Pass Option can only be used with Independent and Selector Regulators (Option 2 & 3 in Sandwich Block Function).

Ordering Components

- Manifold or Subbase Kit required.
- Sandwich Regulator Kit configured for Internal Pilot as standard.
- Order valve as External Pilot.

How to Configure Sandwich Regulator / Valve Combinations

Internal Pilot Configuration -

Pressure in Base Port 1 feeds regulator configured for Internal Pilot which feeds valve configured for External Pilot.

External Pilot Configuration - DX1, DX2, DX3

An External Pilot pressure in Port 12 or 14 of the base feeds thru the Sandwich Regulator 12 or 14 galley directly to the 12/14 pilot of the valve. This configuration takes an External Pilot from the 12 port of the base and passes it thru the regulator to feed the 12 galley of the valve.





Female Electrical Connectors / Accessories
30mm Square 3-Pin – ISO 4400, DIN 43650A
(Use with Enclosure “A”)

Connector	Connector with 6' (2m) Cord	Description
PS2028BP	PS2028JBP	Unlighted
PS203279BP	PS2032J79BP*	Light – 6-48V, 50/60Hz, 6-48VDC
PS203283BP	PS2032J83BP*	Light – 120V/60Hz
PS203283BP	N/A	Light – 240V/60Hz

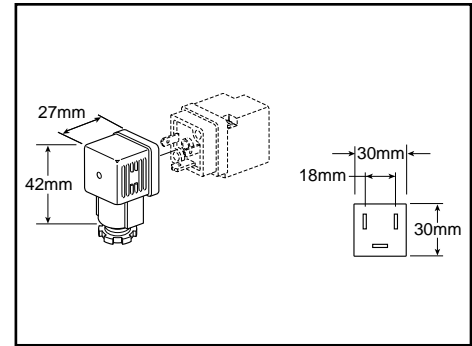

* LED with surge suppression.

Note: Max ϕ 6.5mm cable size required for connector w/o 6' (2m) cord. IP65 rated when properly installed.

Engineering Data:

Conductors: 2 Poles Plus Ground; Cable Range (Connector Only): 8 to 10mm (0.31 to 0.39 Inch); Contact Spacing: 18mm

22mm Rectangular 3-Pin – Type B Industrial
(Use with Enclosure “B”)

Connector	Connector with 6' (2m) Cord	Description
PS2429BP	PS2429JBP	Unlighted
PS243079BP	PS2430J79BP*	Light – 24V/60Hz, 24VDC
PS243083BP	PS2430J83BP*	Light – 120V/60Hz
PS243087BP	N/A	Light – 240V/60Hz

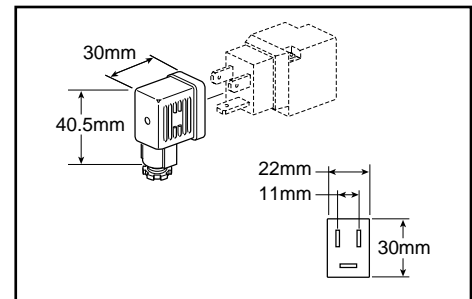

* LED with surge suppression.

Note: Max ϕ 6.5mm cable size required for connector w/o 6' (2m) cord. IP65 rated when properly installed.

Engineering Data:

Conductors: 2 Poles Plus Ground; Cable Range (Connector Only): 6 to 8mm (0.24 to 0.31 Inch); Contact Spacing: 11mm

CNOMO Operator Adapter

Description	Kit Number
Operator Adapter	PS2855P



F



DX1

DX2

DX3

DX1 / DX2 / DX3

Internal / External Pilot Conversion Instructions

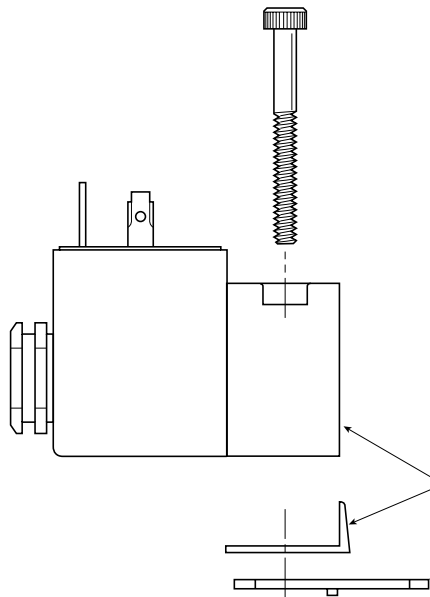

Remove Solenoid Assembly, CNOMO Operator Adapter

Gasket

NOTE:

For Single Solenoid & Double Solenoid – Both 14 & 12 end Gaskets must be converted and both 12 & 14 ports in the Manifold & Subbase must have external pilot supplied.

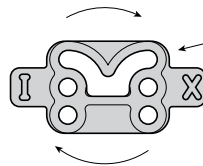
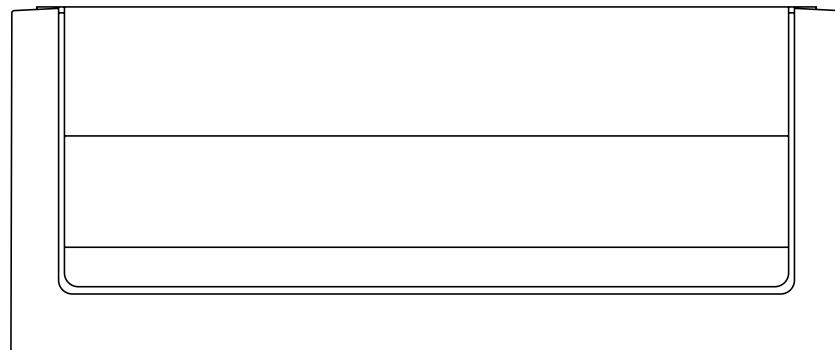

Remove Gasket and Rotate to Show “I” in Position as Shown and Reinstall Gasket and Covers. (Valve is Now External Pilot)

Position of Gasket for Internal Pilot When Using With Solenoid Operator

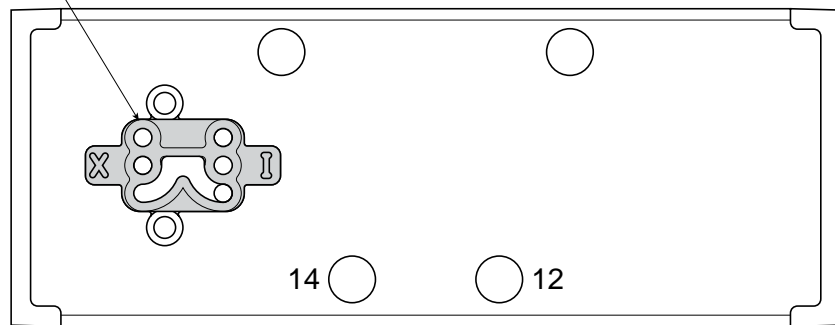



DX1

DX2

DX3

Air Operated Valves

Series	A	B	C	D
DX1	4.72 (120)	1.65 (42)	1.85 (47)	.20 (5)
DX2	5.51 (140)	2.13 (54)	2.30 (58.5)	.20 (5)
DX3	6.69 (170)	2.68 (68)	2.80 (71)	.20 (5)

Inches (mm)

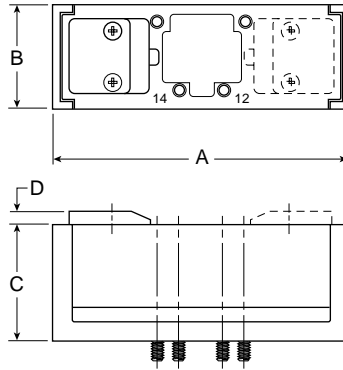

DX1

DX2

DX3

Solenoid Operated Valves

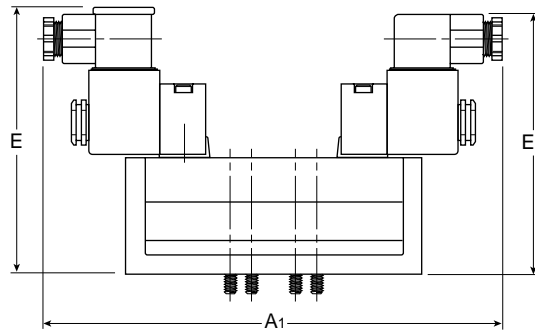

Series	A ₁	E	E ₁	E ₂
DX1	7.97 (202.5)	4.43 (112.5)	4.69 (119)	4.53 (115)
DX2	8.58 (218)	4.86 (123.5)	5.12 (130)	4.98 (126.5)
DX3	9.27 (235.5)	5.35 (136)	5.61 (142.5)	5.47 (139)

Inches (mm)

F

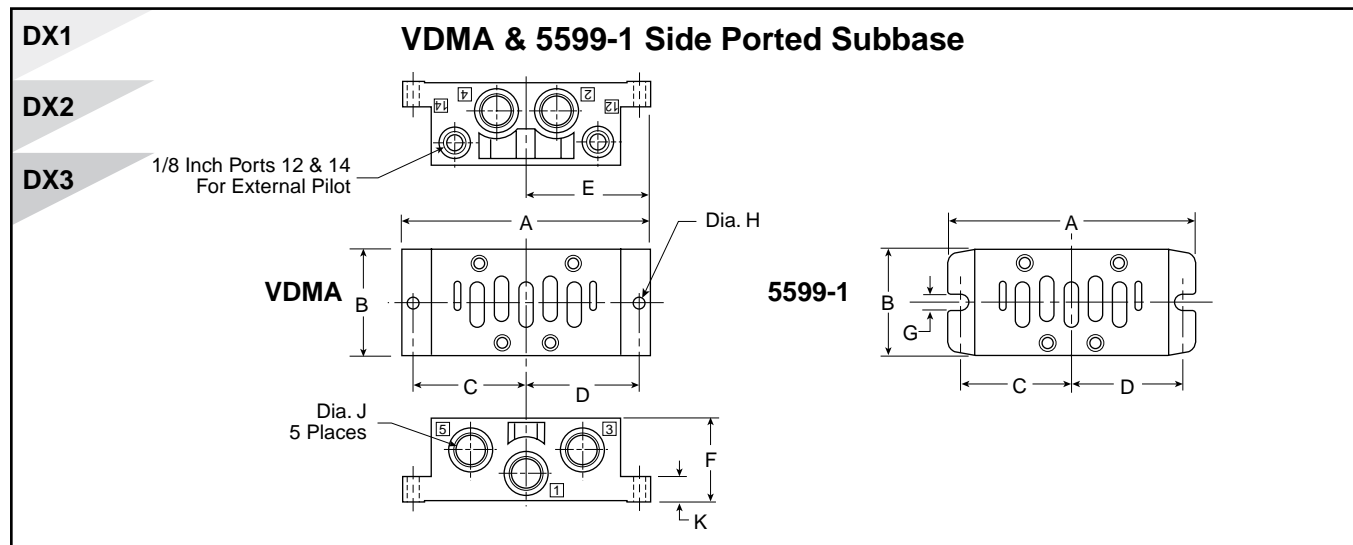

	Series	Part Number	J	A	B	C	D	E	F	G	H	K
VDMA	DX1	P2N-VS512SD	BSPP G1/4	4.33 (110)	1.89 (48)	1.93 (49)	1.93 (49)	2.17 (55)	1.26 (32)	—	.22 (5.6)	.39 (9.9)
	DX2	P2N-WS513SD	BSPP G3/8	4.88 (124)	2.21 (56)	2.21 (56)	2.21 (56)	2.44 (62)	1.57 (40)	—	0.26 (6.6)	.51 (13)
	DX3	P2N-YS514SD	BSPP G1/2	5.87 (149)	2.80 (71)	2.68 (68)	2.68 (68)	2.93 (74.5)	2.05 (52)	—	0.26 (6.6)	0.71 (18)
5599-1	DX1	PL1-1/4-70	BSPP G1/4	4.33 (110)	1.81 (46)	1.93 (49)	1.93 (49)	2.17 (55)	1.14 (29)	0.22 (5.5)	—	0.24 (6)
		PL1-1/4-80	NPT 1/4									
	DX2	PL2-3/8-70	BSPP G3/8	4.88 (124)	2.21 (56)	2.17 (55)	2.17 (55)	2.44 (62)	1.46 (37)	0.22 (5.5)	—	0.24 (6)
		PL2-3/8-80	NPT 3/8									
	DX3	PL3-1/2-70	BSPP G1/2	5.87 (149)	2.80 (71)	2.68 (68)	2.68 (68)	2.93 (74.5)	2.36 (60)	0.26 (6.6)	—	0.71 (18)
		PL3-1/2-80	NPT 1/2									

Inches (mm)

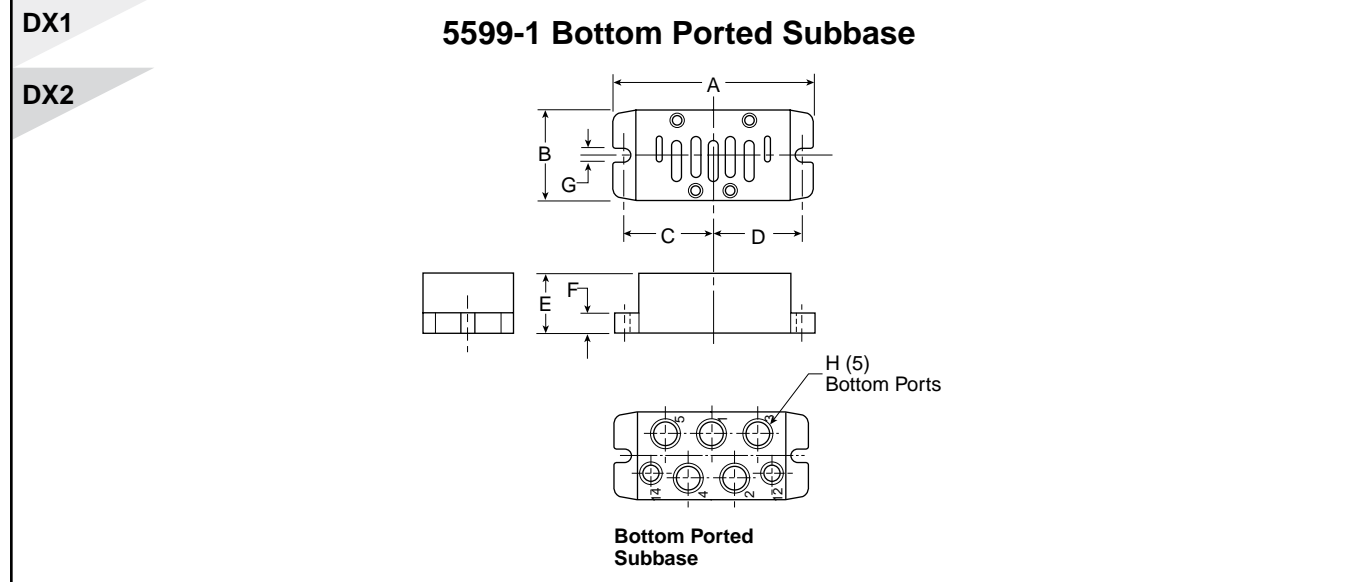

Series	Part Number	H	A	B	C	D	E	F	G
DX1	PD1-1/4-70	BSPP G1/4	4.33 (110)	1.81 (46)	1.93 (49)	1.93 (49)	1.14 (29)	.24 (6)	0.22 (5.5)
	PD1-1/4-80	NPT1/4							
DX2	PD2-3/8-70	BSPP G3/8	4.88 (124)	2.20 (56)	2.17 (55)	2.17 (55)	1.46 (37)	.24 (6)	.0.22 (5.5)
	PD2-3/8-80	NPT3/8							

Inches (mm)





DX1

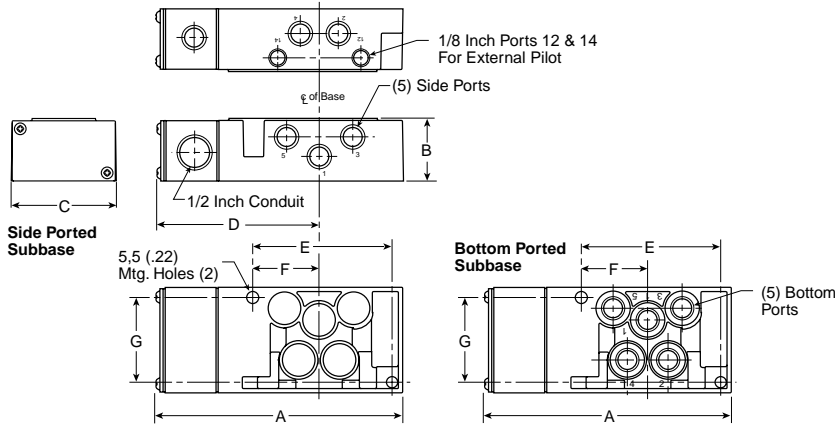

PS4011 Subbase

A	B	C	D
5.83 (148)	1.48 (38)	2.50 (64)	3.86 (98)
E	F	G	
3.29 (84)	1.57 (40)	2.00 (51)	

Inches (mm)

DX2

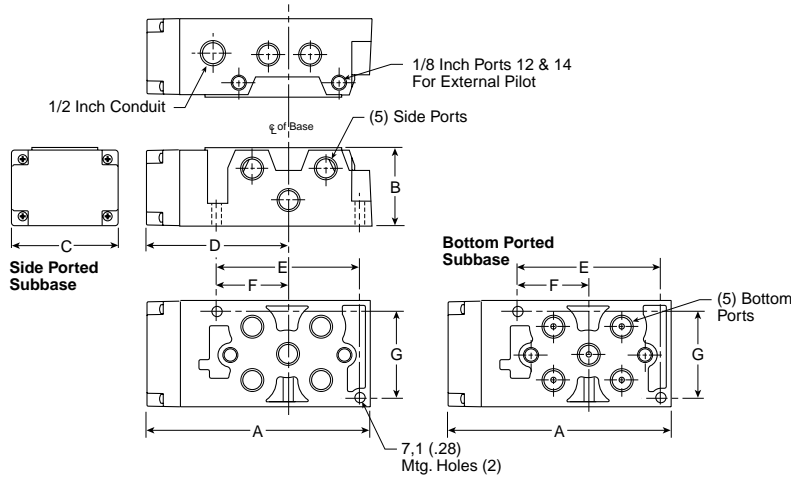

PS4111 Subbase

A	B	C	D
6.69 (170)	2.33 (59)	3.15 (80)	4.25 (108)
E	F	G	
4.21 (107)	2.07 (52)	2.56 (65)	

Inches (mm)

DX3

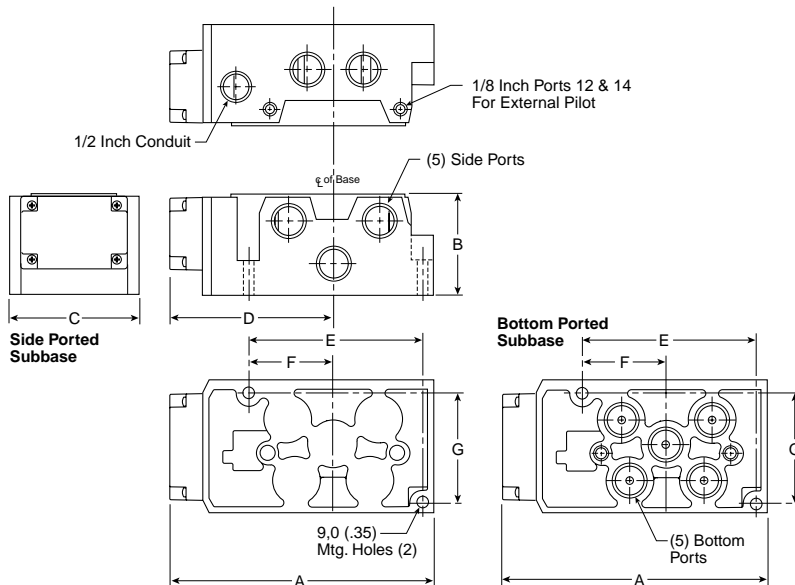

PS4211 Subbase

A	B	C	D
7.90 (201)	2.96 (75)	3.90 (99)	4.92 (125)
E	F	G	
5.14 (131)	2.50 (64)	3.24 (82)	

Inches (mm)

F



DX1

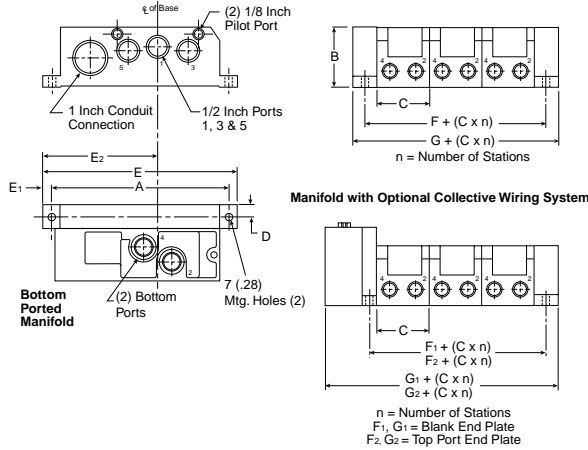

PS4011 Manifold

A 6.50 (165)	B 2.20 (56)	C 1.93 (49)	D .44 (11)	E 7.15 (182)
E₁ .33 (8)	E₂ 4.25 (108)	F .87 (22)	F₁ .64 (16)	F₂ .90 (23)
G 1.80 (46)	G₁* 2.56 (65)	G₂* 3.26 (83)		

Inches (mm)
 * For 19-Pin Round Connector Module, add 1.08" (27.5mm) to the G₁ & G₂ dimensions.

DX2

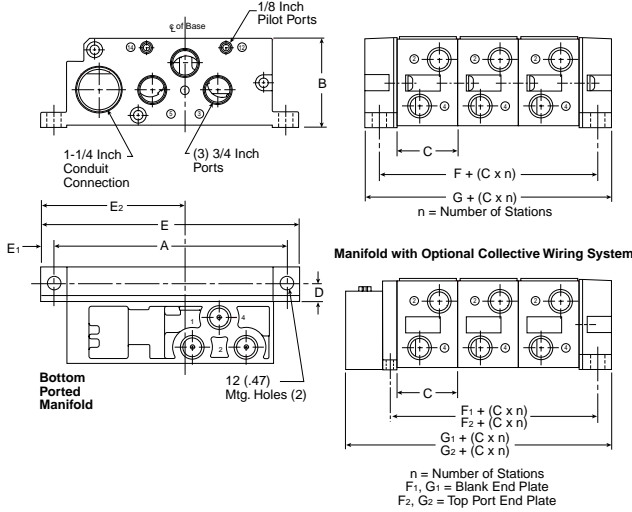

PS4111 Manifold

A 8.46 (215)	B 3.35 (85)	C 2.20 (56)	D .59 (15)	E 9.41 (239)
E₁ .47 (12)	E₂ 5.28 (134)	F 1.18 (30)	F₁ 1.06 (27)	F₂ 1.30 (33)
G 2.36 (60)	G₁* 3.41 (87)	G₂* 3.88 (99)		

Inches (mm)
 * For 19-Pin Round Connector Module, add 1.08" (27.5mm) to the G₁ & G₂ dimensions.

DX3

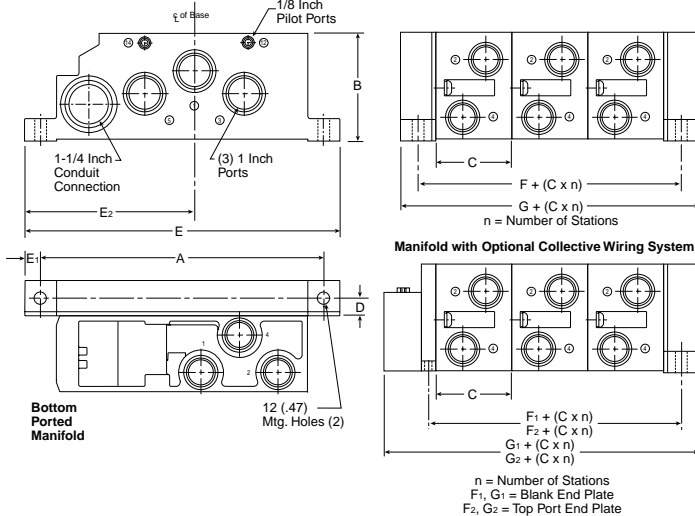

PS4211 Manifold

A 10.41 (265)	B 4.13 (105)	C 2.80 (71)	D .65 (175)	E 11.61 (295)
E₁ .59 (15)	E₂ 6.26 (159)	F 1.30 (33)	F₁ 1.12 (29)	F₂ 1.59 (41)
G 2.60 (63)	G₁* 3.54 (90)	G₂* 4.49 (114)		

Inches (mm)
 * For 19-Pin Round Connector Module, add 1.08" (27.5mm) to the G₁ & G₂ dimensions.





DX1

DX2

DX3

**5599-1 VDMA – Form C Manifold
&
5599-1 VDMA - Form D End Plates**

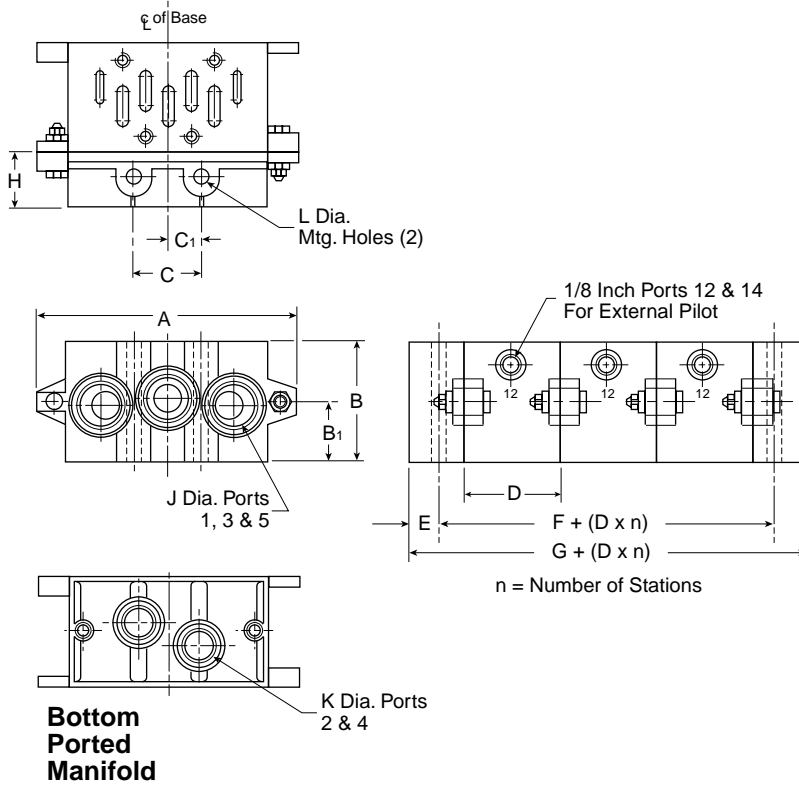

VDMA Form C Manifold

Series	Part Number	A	B	B ₁	D	E	F	G	J	K
DX1	P2N-VM512MD	4.33 (110)	1.81 (46)	0.94 (24)	1.69 (55)	0.43 (22)	0.87 (22)	1.73 (44)	BSPP G3/8	BSPP G1/4
DX2	P2N-WM513MD	5.31 (135)	1.85 (47)	0.94 (24)	2.20 (56)	0.51 (13)	1.02 (26)	2.05 (52)	BSPP G1/2	BSPP G3/8
DX3	P2N-YM514MD	7.48 (190)	2.20 (56)	1.34 (34)	2.80 (71)	0.59 (15)	1.18 (30)	2.36 (60)	BSPP G1	BSPP G1/2

VDMA Form D End Plate

Series	Part Number	A	B	B ₁	C	C ₁	H	L
DX1	P2N-VM513ES	4.33 (110)	1.81 (46)	0.94 (24)	1.10 (28)	0.55 (14)	0.87 (22)	0.28 (7)
DX2	P2N-WM514ES	5.31 (135)	1.85 (47)	0.94 (24)	1.38 (35)	0.69 (18)	1.02 (26)	0.34 (9)
DX3	P2N-YM518ES	7.48 (190)	2.20 (56)	1.34 (34)	2.05 (52)	1.03 (26)	1.18 (30)	0.47 (12)

Inches (mm)

F





Safety Guide For Selecting And Using Pneumatic Division Products And Related Accessories

WARNING:

FAILURE OR IMPROPER SELECTION OR IMPROPER USE OF PNEUMATIC DIVISION PRODUCTS, ASSEMBLIES OR RELATED ITEMS ("PRODUCTS") CAN CAUSE DEATH, PERSONAL INJURY, AND PROPERTY DAMAGE. POSSIBLE CONSEQUENCES OF FAILURE OR IMPROPER SELECTION OR IMPROPER USE OF THESE PRODUCTS INCLUDE BUT ARE NOT LIMITED TO:

- Unintended or mistimed cycling or motion of machine members or failure to cycle
- Work pieces or component parts being thrown off at high speeds.
- Failure of a device to function properly for example, failure to clamp or unclamp an associated item or device.
- Explosion
- Suddenly moving or falling objects.
- Release of toxic or otherwise injurious liquids or gasses.

Before selecting or using any of these Products, it is important that you read and follow the instructions below.

1. GENERAL INSTRUCTIONS

- 1.1. Scope:** This safety guide is designed to cover general guidelines on the installation, use, and maintenance of Pneumatic Division Valves, FRLs (Filters, Pressure Regulators, and Lubricators), Vacuum products and related accessory components.
- 1.2. Fail-Safe:** Valves, FRLs, Vacuum products and their related components can and do fail without warning for many reasons. Design all systems and equipment in a fail-safe mode, so that failure of associated valves, FRLs or Vacuum products will not endanger persons or property.
- 1.3. Relevant International Standards:** For a good guide to the application of a broad spectrum of pneumatic fluid power devices see: ISO 4414:1998, Pneumatic Fluid Power – General Rules Relating to Systems. See www.iso.org for ordering information.
- 1.4. Distribution:** Provide a copy of this safety guide to each person that is responsible for selection, installation, or use of Valves, FRLs or Vacuum products. Do not select, or use Parker valves, FRLs or vacuum products without thoroughly reading and understanding this safety guide as well as the specific Parker publications for the products considered or selected.
- 1.5. User Responsibility:** Due to the wide variety of operating conditions and applications for valves, FRLs, and vacuum products Parker and its distributors do not represent or warrant that any particular valve, FRL or vacuum product is suitable for any specific end use system. This safety guide does not analyze all technical parameters that must be considered in selecting a product. The user, through its own analysis and testing, is solely responsible for:
 - Making the final selection of the appropriate valve, FRL, Vacuum component, or accessory.
 - Assuring that all user's performance, endurance, maintenance, safety, and warning requirements are met and that the application presents no health or safety hazards.
 - Complying with all existing warning labels and / or providing all appropriate health and safety warnings on the equipment on which the valves, FRLs or Vacuum products are used; and,
 - Assuring compliance with all applicable government and industry standards.
- 1.6. Safety Devices:** Safety devices should not be removed, or defeated.
- 1.7. Warning Labels:** Warning labels should not be removed, painted over or otherwise obscured.
- 1.8. Additional Questions:** Call the appropriate Parker technical service department if you have any questions or require any additional information. See the Parker publication for the product being considered or used, or call 1-800-CPARKER, or go to www.parker.com, for telephone numbers of the appropriate technical service department.

2. PRODUCT SELECTION INSTRUCTIONS

- 2.1. Flow Rate:** The flow rate requirements of a system are frequently the primary consideration when designing any pneumatic system. System components need to be able to provide adequate flow and pressure for the desired application.
- 2.2. Pressure Rating:** Never exceed the rated pressure of a product. Consult product labeling, Pneumatic Division catalogs or the instruction sheets supplied for maximum pressure ratings.
- 2.3. Temperature Rating:** Never exceed the temperature rating of a product. Excessive heat can shorten the life expectancy of a product and result in complete product failure.
- 2.4. Environment:** Many environmental conditions can affect the integrity and suitability of a product for a given application. Pneumatic Division products are designed for use in general purpose industrial applications. If these products are to be used in unusual circumstances such as direct sunlight and/or corrosive or caustic environments, such use can shorten the useful life and lead to premature failure of a product.
- 2.5. Lubrication and Compressor Carryover:** Some modern synthetic oils can and will attack nitrile seals. If there is any possibility of synthetic oils or greases migrating into the pneumatic components check for compatibility with the seal materials used. Consult the factory or product literature for materials of construction.
- 2.6. Polycarbonate Bowls and Sight Glasses:** To avoid potential polycarbonate bowl failures:
 - Do not locate polycarbonate bowls or sight glasses in areas where they could be subject to direct sunlight, impact blow, or temperatures outside of the rated range.
 - Do not expose or clean polycarbonate bowls with detergents, chlorinated hydro-carbons, ketones, esters or certain alcohols.
 - Do not use polycarbonate bowls or sight glasses in air systems where compressors are lubricated with fire resistant fluids such as phosphate ester and di-ester lubricants.

Safety Guide

2.7. Chemical Compatibility: For more information on plastic component chemical compatibility see Pneumatic Division technical bulletins Tec-3, Tec-4, and Tec-5

- 2.8. Product Rupture:** Product rupture can cause death, serious personal injury, and property damage.
- Do not connect pressure regulators or other Pneumatic Division products to bottled gas cylinders.
 - Do not exceed the maximum primary pressure rating of any pressure regulator or any system component.
 - Consult product labeling or product literature for pressure rating limitations.

3. PRODUCT ASSEMBLY AND INSTALLATION INSTRUCTIONS

- 3.1. Component Inspection:** Prior to assembly or installation a careful examination of the valves, FRLs or vacuum products must be performed. All components must be checked for correct style, size, and catalog number. DO NOT use any component that displays any signs of nonconformance.
- 3.2. Installation Instructions:** Parker published Installation Instructions must be followed for installation of Parker valves, FRLs and vacuum components. These instructions are provided with every Parker valve or FRL sold, or by calling 1-800-CPARKER, or at www.parker.com.
- 3.3. Air Supply:** The air supply or control medium supplied to Valves, FRLs and Vacuum components must be moisture-free if ambient temperature can drop below freezing

4. VALVE AND FRL MAINTENANCE AND REPLACEMENT INSTRUCTIONS

- 4.1. Maintenance:** Even with proper selection and installation, valve, FRL and vacuum products service life may be significantly reduced without a continuing maintenance program. The severity of the application, risk potential from a component failure, and experience with any known failures in the application or in similar applications should determine the frequency of inspections and the servicing or replacement of Pneumatic Division products so that products are replaced before any failure occurs. A maintenance program must be established and followed by the user and, at minimum, must include instructions 4.2 through 4.10.
- 4.2. Installation and Service Instructions:** Before attempting to service or replace any worn or damaged parts consult the appropriate Service Bulletin for the valve or FRL in question for the appropriate practices to service the unit in question. These Service and Installation Instructions are provided with every Parker valve and FRL sold, or are available by calling 1-800-CPARKER, or by accessing the Parker web site at www.parker.com.
- 4.3. Lockout / Tagout Procedures:** Be sure to follow all required lockout and tagout procedures when servicing equipment. For more information see: OSHA Standard – 29 CFR, Part 1910.147, Appendix A, The Control of Hazardous Energy – (Lockout / Tagout)
- 4.4. Visual Inspection:** Any of the following conditions requires immediate system shut down and replacement of worn or damaged components:
- Air leakage: Look and listen to see if there are any signs of visual damage to any of the components in the system. Leakage is an indication of worn or damaged components.
 - Damaged or degraded components: Look to see if there are any visible signs of wear or component degradation.
 - Kinked, crushed, or damaged hoses. Kinked hoses can result in restricted air flow and lead to unpredictable system behavior.
 - Any observed improper system or component function: Immediately shut down the system and correct malfunction.
 - Excessive dirt build-up: Dirt and clutter can mask potentially hazardous situations.

Caution: Leak detection solutions should be rinsed off after use.

4.5. Routine Maintenance Issues:

- Remove excessive dirt, grime and clutter from work areas.
- Make sure all required guards and shields are in place.

4.6. Functional Test: Before initiating automatic operation, operate the system manually to make sure all required functions operate properly and safely.

4.7. Service or Replacement Intervals: It is the user's responsibility to establish appropriate service intervals. Valves, FRLs and vacuum products contain components that age, harden, wear, and otherwise deteriorate over time. Environmental conditions can significantly accelerate this process. Valves, FRLs and vacuum components need to be serviced or replaced on routine intervals. Service intervals need to be established based on:

- Previous performance experiences.
- Government and / or industrial standards.
- When failures could result in unacceptable down time, equipment damage or personal injury risk.

4.8. Servicing or Replacing of any Worn or Damaged Parts: To avoid unpredictable system behavior that can cause death, personal injury and property damage:

- Follow all government, state and local safety and servicing practices prior to service including but not limited to all OSHA Lockout Tagout procedures (OSHA Standard – 29 CFR, Part 1910.147, Appendix A, The Control of Hazardous Energy – Lockout / Tagout).
- Disconnect electrical supply (when necessary) before installation, servicing, or conversion.
- Disconnect air supply and depressurize all air lines connected to system and Pneumatic Division products before installation, service, or conversion.
- Installation, servicing, and / or conversion of these products must be performed by knowledgeable personnel who understand how pneumatic products are to be applied.
- After installation, servicing, or conversions air and electrical supplies (when necessary) should be connected and the product tested for proper function and leakage. If audible leakage is present, or if the product does not operate properly, do not put product or system into use.
- Warnings and specifications on the product should not be covered or painted over. If masking is not possible, contact your local representative for replacement labels.

4.9. Putting Serviced System Back into Operation: Follow the guidelines above and all relevant Installation and Maintenance Instructions supplied with the valve FRL or vacuum component to insure proper function of the system.

The items described in this document and other documents and descriptions provided by Parker Hannifin Corporation, its subsidiaries and its authorized distributors ("Seller") are hereby offered for sale at prices to be established by Seller. This offer and its acceptance by any customer ("Buyer") shall be governed by all of the following Terms and Conditions. Buyer's order for any item described in its document, when communicated to Seller verbally, or in writing, shall constitute acceptance of this offer. All goods or work described will be referred to as "Products".

1. Terms and Conditions. Seller's willingness to offer Products, or accept an order for Products, to or from Buyer is subject to these Terms and Conditions or any newer version of the terms and conditions found on-line at www.parker.com/saleterms/. Seller objects to any contrary or additional terms or conditions of Buyer's order or any other document issued by Buyer.

2. Price Adjustments; Payments. Prices stated on Seller's quote or other documentation offered by Seller are valid for 30 days, and do not include any sales, use, or other taxes unless specifically stated. Unless otherwise specified by Seller, all prices are F.C.A. Seller's facility (INCOTERMS 2010). Payment is subject to credit approval and is due 30 days from the date of invoice or such other term as required by Seller's Credit Department, after which Buyer shall pay interest on any unpaid invoices at the rate of 1.5% per month or the maximum allowable rate under applicable law.

3. Delivery Dates; Title and Risk; Shipment. All delivery dates are approximate and Seller shall not be responsible for any damages resulting from any delay. Regardless of the manner of shipment, title to any products and risk of loss or damage shall pass to Buyer upon placement of the products with the shipment carrier at Seller's facility. Unless otherwise stated, Seller may exercise its judgment in choosing the carrier and means of delivery. No deferment of shipment at Buyers' request beyond the respective dates indicated will be made except on terms that will indemnify, defend and hold Seller harmless against all loss and additional expense. Buyer shall be responsible for any additional shipping charges incurred by Seller due to Buyer's acts or omissions.

4. Warranty. Seller warrants that the Products sold hereunder shall be free from defects in material or workmanship for a period of twelve months from the date of delivery to Buyer or 2,000 hours of normal use, whichever occurs first. The prices charged for Seller's products are based upon the exclusive limited warranty stated above, and upon the following disclaimer: **DISCLAIMER OF WARRANTY: THIS WARRANTY COMPRISES THE SOLE AND ENTIRE WARRANTY PERTAINING TO PRODUCTS PROVIDED HEREUNDER. SELLER DISCLAIMS ALL OTHER WARRANTIES, EXPRESS AND IMPLIED, INCLUDING DESIGN, MERCHANTABILITY AND FITNESS FOR A PARTICULAR PURPOSE.**

5. Claims; Commencement of Actions. Buyer shall promptly inspect all Products upon delivery. No claims for shortages will be allowed unless reported to the Seller within 10 days of delivery. No other claims against Seller will be allowed unless asserted in writing within 30 days after delivery. Buyer shall notify Seller of any alleged breach of warranty within 30 days after the date the defect is or should have been discovered by Buyer. Any action based upon breach of this agreement or upon any other claim arising out of this sale (other than an action by Seller for an amount due on any invoice) must be commenced within 12 months from the date of the breach without regard to the date breach is discovered.

6. LIMITATION OF LIABILITY. UPON NOTIFICATION, SELLER WILL, AT ITS OPTION, REPAIR OR REPLACE A DEFECTIVE PRODUCT, OR REFUND THE PURCHASE PRICE. **IN NO EVENT SHALL SELLER BE LIABLE TO BUYER FOR ANY SPECIAL, INDIRECT, INCIDENTAL OR CONSEQUENTIAL DAMAGES ARISING OUT OF, OR AS THE RESULT OF, THE SALE, DELIVERY, NON-DELIVERY, SERVICING, USE OR LOSS OF USE OF THE PRODUCTS OR ANY PART THEREOF, OR FOR ANY CHARGES OR EXPENSES OF ANY NATURE INCURRED WITHOUT SELLER'S WRITTEN CONSENT, EVEN IF SELLER HAS BEEN NEGLIGENT, WHETHER IN CONTRACT, TORT OR OTHER LEGAL THEORY. IN NO EVENT SHALL SELLER'S LIABILITY UNDER ANY CLAIM MADE BY BUYER EXCEED THE PURCHASE PRICE OF THE PRODUCTS.**

7. User Responsibility. The user, through its own analysis and testing, is solely responsible for making the final selection of the system and Product and assuring that all performance, endurance, maintenance, safety and warning requirements of the application are met. The user must analyze all aspects of the application and follow applicable industry standards and Product information. If Seller provides Product or system options, the user is responsible for determining that such data and specifications are suitable and sufficient for all applications and reasonably foreseeable uses of the Products or systems.

8. Loss to Buyer's Property. Any designs, tools, patterns, materials, drawings, confidential information or equipment furnished by Buyer or any other items which become Buyer's property, may be considered obsolete and may be destroyed by Seller after two consecutive years have elapsed without Buyer ordering the items manufactured using such property. Seller shall not be responsible for any loss or damage to such property while it is in Seller's possession or control.

9. Special Tooling. A tooling charge may be imposed for any special tooling, including without limitation, dies, fixtures, molds and patterns, acquired to manufacture Products. Such special tooling shall be and remain Seller's property notwithstanding payment of any charges by Buyer. In no event will Buyer acquire any interest in apparatus belonging to Seller which is utilized in the manufacture of the Products, even if such apparatus has been specially converted or adapted for such manufacture and notwithstanding any charges paid by Buyer. Unless otherwise agreed, Seller shall have the right to alter, discard or otherwise dispose of any special tooling or other property in its sole discretion at any time.

10. Buyer's Obligation; Rights of Seller. To secure payment of all sums due or otherwise, Seller shall retain a security interest in the goods delivered and this agreement shall be deemed a Security Agreement under the Uniform Commercial Code. Buyer authorizes Seller as its attorney to execute and file on Buyer's behalf all documents Seller deems necessary to perfect its security interest.

11. Improper use and Indemnity. Buyer shall indemnify, defend, and hold Seller harmless from any claim, liability, damages, lawsuits, and costs (including attorney fees), whether for personal injury, property damage, patent, trademark or copyright

infringement or any other claim, brought by or incurred by Buyer, Buyer's employees, or any other person, arising out of: (a) improper selection, improper application or other misuse of Products purchased by Buyer from Seller; (b) any act or omission, negligent or otherwise, of Buyer; (c) Seller's use of patterns, plans, drawings, or specifications furnished by Buyer to manufacture Product; or (d) Buyer's failure to comply with these terms and conditions. Seller shall not indemnify Buyer under any circumstance except as otherwise provided.

12. Cancellations and Changes. Orders shall not be subject to cancellation or change by Buyer for any reason, except with Seller's written consent and upon terms that will indemnify, defend and hold Seller harmless against all direct, incidental and consequential loss or damage. Seller may change product features, specifications, designs and availability with notice to Buyer.

13. Limitation on Assignment. Buyer may not assign its rights or obligations under this agreement without the prior written consent of Seller.

14. Force Majeure. Seller does not assume the risk and shall not be liable for delay or failure to perform any of Seller's obligations by reason of circumstances beyond the reasonable control of Seller (hereinafter "Events of Force Majeure") Events of Force Majeure shall include without limitation: accidents, strikes or labor disputes, acts of any government or government agency, acts of nature, delays or failures in delivery from carriers or suppliers, shortages of materials, or any other cause beyond Seller's reasonable control.

15. Waiver and Severability. Failure to enforce any provision of this agreement will not waive that provision nor will any such failure prejudice Seller's right to enforce that provision in the future. Invalidation of any provision of this agreement by legislation or other rule of law shall not invalidate any other provision herein. The remaining provisions of this agreement will remain in full force and effect.

16. Termination. Seller may terminate this agreement for any reason and at any time by giving Buyer thirty (30) days written notice of termination. Seller may immediately terminate this agreement, in writing, if Buyer: (a) commits a breach of any provision of this agreement (b) appointments a trustee, receiver or custodian for all or any part of Buyer's property (c) files a petition for relief in bankruptcy on its own behalf, or by a third party (d) makes an assignment for the benefit of creditors, or (e) the dissolves or liquidates all or a majority of its assets.

17. Governing Law. This agreement and the sale and delivery of all Products hereunder shall be deemed to have taken place in and shall be governed and construed in accordance with the laws of the State of Ohio, as applicable to contracts executed and wholly performed therein and without regard to conflicts of laws principles. Buyer irrevocably agrees and consents to the exclusive jurisdiction and venue of the courts of Cuyahoga County, Ohio with respect to any dispute, controversy or claim arising out of or relating to this agreement.

18. Indemnity for Infringement of Intellectual Property Rights. Seller shall have no liability for infringement of any patents, trademarks, copyrights, trade dress, trade secrets or similar rights except as provided in this Section. Seller will defend and indemnify Buyer against allegations of infringement of U.S. patents, U.S. trademarks, copyrights, trade dress and trade secrets ("Intellectual Property Rights"). Seller will defend at its expense and will pay the cost of any settlement or damages awarded in an action brought against Buyer based on an allegation that a Product sold pursuant to this Agreement infringes the Intellectual Property Rights of a third party. Seller's obligation to defend and indemnify Buyer is contingent on Buyer notifying Seller within ten (10) days after Buyer becomes aware of such allegations of infringement, and Seller having sole control over the defense of any allegations or actions including all negotiations for settlement or compromise. If a Product is subject to a claim that it infringes the Intellectual Property Rights of a third party, Seller may, at its sole expense and option, procure for Buyer the right to continue using the Product, replace or modify the Product so as to make it noninfringing, or offer to accept return of the Product and return the purchase price less a reasonable allowance for depreciation. Notwithstanding the foregoing, Seller shall have no liability for claims of infringement based on information provided by Buyer, or directed to Products delivered hereunder for which the designs are specified in whole or part by Buyer, or infringements resulting from the modification, combination or use in a system of any Product sold hereunder. The foregoing provisions of this Section shall constitute Seller's sole and exclusive liability and Buyer's sole and exclusive remedy for infringement of Intellectual Property Rights.

19. Entire Agreement. This agreement contains the entire agreement between the Buyer and Seller and constitutes the final, complete and exclusive expression of the terms of sale. All prior or contemporaneous written or oral agreements or negotiations with respect to the subject matter are herein merged.

20. Compliance with Law, U. K. Bribery Act and U.S. Foreign Corrupt Practices Act. Buyer agrees to comply with all applicable laws and regulations, including both those of the United Kingdom and the United States of America, and of the country or countries of the Territory in which the Buyer may operate, including without limitation the U. K. Bribery Act, the U.S. Foreign Corrupt Practices Act ("FCPA") and the U.S. Anti-Kickback Act (the "Anti-Kickback Act"), and agrees to indemnify and hold harmless Seller from the consequences of any violation of such provisions by Buyer, its employees or agents. Buyer acknowledges that they are familiar with the provisions of the U. K. Bribery Act, the FCPA and the Anti-Kickback Act, and certifies that Buyer will adhere to the requirements thereof. In particular, Buyer represents and agrees that Buyer shall not make any payment or give anything of value, directly or indirectly to any governmental official, any foreign political party or official thereof, any candidate for foreign political office, or any commercial entity or person, for the purpose of influencing such person to purchase products or otherwise benefit the business of Seller.

02/12

Extensive Automation Solutions

Linear Actuators



Aluminum and steel pneumatic cylinders, guided cylinders, rodless cylinders, and short stroke thrusters from the industry leader.

www.parker.com/pneu/linear

Air Control Valves



Valve technology that meets the most demanding requirements in any industrial application.

www.parker.com/pneu/valve

Air Preparation



Parker, the industry leader in air preparation, offers a complete line of products to ensure clean, dry, oil-free air.

www.parker.com/pneu/airprep

Connectors and Tubing



The most complete line of fluid connectors worldwide will meet virtually any automation application.

www.parker.com/pneu/fc

Rotary Actuators



Industry leader in the design and manufacture of pneumatic rack and pinion, and vane style rotary actuators.

www.parker.com/pneu/rotary

Vacuum Products and Sensors



Vacuum solutions include a broad range of generators (integrated / inline), cups, and pressure sensors.

www.parker.com/pneu/vacsen

Grippers



Parallel, angular, and three jaw grippers are available in over 1,000 configurations.

www.parker.com/pneu/gripper

Airline Accessories



Airline accessories include silencers, flow controls, and mufflers to round out Parker's pneumatic solution.

www.parker.com/pneu/access

Electric Actuators



Screw, belt-driven, and linear motor actuators for the complete range of industrial applications, offering precise motion and flexibility.

www.parker.com/em/linear

Motors and Drives



Built using industry standard interfaces and market-leading features that combine great value and performance.

www.parker.com/em/motordrive

HMI and Controllers



Superior integration and support for machine control as well as HMI hardware and software.

www.parker.com/em/hmicont

Parker IPS Structural Automation

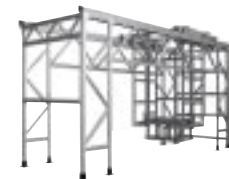

More than 150 metric and inch profiles, integral motion components, and accessories for unlimited and flexible configurations. Pre-machined kits or complete assemblies.

www.parker.com/ips

Covering Electromechanical and Pneumatic markets, each of our catalogs is paired with an interactive CD. Call for your comprehensive guides today. 1-800-CParker



Electromechanical
Precision Bulletin
AU01-5000/US

Electromechanical
Industrial Bulletin
AU01-7500/US

Pneumatic Bulletin
AU01-1000/US

THE GLOBAL LEADER IN MOTION AND CONTROL TECHNOLOGIES



Parker Hannifin Corporation
Pneumatic Division
8676 E. M89
P.O. Box 901
Richland, MI 49083 USA
Tel: (269) 629-5000
Fax: (269) 629-5385

Applications Engineering

Phone: (269) 629-5575 Option #3
E-mail: pdnapps@parker.com

Customer Support

Phone: (269) 629-5575 Option #1
E-mail: pdncustsvc@parker.com
Web site: www.parker.com/pneumatics